



COUNTY OF YOLO
Improvement Standards
Section 11
Stormwater Quality, Erosion and
Sediment Control

Approved by the Board of Supervisors

August 1, 2006

**County of Yolo
Improvement Standards**

Section 11
Stormwater Quality, Erosion and Sediment Control

Table of Contents

11-1 ABBREVIATIONS / ACRONYMS 2

11-2 GOOD HOUSEKEEPING PRACTICES 3

 11-2.1 ALL CONSTRUCTION SITES REGARDLESS OF SIZE 3

 11-2.2 CONSTRUCTION PROJECTS INVOLVING PAINT WORK 4

 11-2.3 CONSTRUCTION PROJECTS INVOLVING CEMENT AND CONCRETE WORK 5

 11-2.4 CONSTRUCTION PROJECTS INVOLVING ROADWORK/PAVEMENT CONSTRUCTION 5

11-3 CONSTRUCTION PROJECTS WITH SOIL DISTURBANCE OF AN ACRE OR MORE: 6

 11-3.1 NOTICE OF INTENT FROM THE REGIONAL WATER QUALITY CONTROL BOARD 7

 11-3.2 STORM WATER POLLUTION PREVENTION PLAN 7

 11-3.3 COUNTY APPROVAL PRIOR TO PROJECT COMMENCEMENT 7

11-4 STORMWATER POLLUTION PREVENTION BEST MANAGEMENT PRACTICES FOR CONSTRUCTION ACTIVITIES: 8

 11-4.1 CONSTRUCTION SEQUENCE SCHEDULE 8

 11-4.2 CONSTRUCTION SITE BMP'S 9

 11-4.3 EROSION AND SEDIMENT CONTROL PLAN 11

 11-4.4 TOP SOILING 11

 11-4.5 PRESERVATION OF EXISTING VEGETATION 12

 11-4.6 HYDROSEEDING 13

 11-4.7 SOIL BINDERS 14

 11-4.8 STABILIZED CONSTRUCTION ACCESS 14

 11-4.9 SEDIMENT TRAP 15

 11-4.10 SEDIMENT BASIN 16

 11-4.11 GEOTEXTILES, MATS, AND EROSION CONTROL BLANKETS 17

 11-4.12 SILT FENCE 19

 11-4.13 STRAW BALE BARRIER 20

 11-4.14 INLET SEDIMENT CONTROL BARRIERS & FILTERS 21

 11-4.15 STRAW MULCH AND HYDRAULIC MULCHING 22

 11-4.16 FIBER ROLLS 23

 11-4.17 CONCRETE WASHOUTS 24

 11-4.18 CLEAN UP 24

 11-4.19 STREET SWEEPING AND VACUUMING 25

11-5 PERMANENT POST-CONSTRUCTION STORMWATER POLLUTION CONTROLS FOR NEW DEVELOPMENT OR REDEVELOPMENT PROJECTS 26

 11-5.1 PROJECT CATEGORIES SUBJECT TO THESE DESIGN STANDARDS: 26

11-5.2 DESIGN STANDARDS APPLICABLE TO ALL CATEGORIES	26
11-5.2.1 Maintain Pre-Development Peak Stormwater Discharge Rates	26
11-5.2.2 Conserve Natural Areas	26
11-5.2.3 Minimize Stormwater Pollutants of Concern	27
11-5.2.3 Protect Slopes and Channels	27
11-5.2.5 Concrete Storm Drain System Stamp or Epoxied Placards	28
11-5.2.6 Outdoor Material Storage Areas	28
11-5.2.7 Trash Storage Areas	29
11-5.2.8 Ongoing BMP Maintenance	29
11-5.2.9 Structural or Treatment Control BMPs	30
11-5.3 DESIGN STANDARDS APPLICABLE TO INDIVIDUAL PRIORITY PROJECT CATEGORIES	30
11-5.3.1 100,000 Square Foot Commercial Developments	30
11-5.3.2 Restaurants	31
11-5.3.3 Retail Gasoline Outlets	32
11-5.3.4 Automotive Repair Shops	32
11-5.3.5 Parking Lots	34

Drawings:

11-4.8	Stabilized Construction Site Access
11-4.9A	Sediment Trap Vegetated Outlet
11-4.9B	Sediment Trap Stabilized Outlet
11-4.10A	Typical Temporary Sediment Basin Single Orifice Design
11-4.10B	Typical Temporary Sediment Basin Multiple Orifice Design
11-4.10C	Multiple Orifice Outlet Riser
11-4.11A	Erosion Control Blankets/Mats Channel Installation
11-4.11B	Erosion Control Blankets/Mats Slope Installation
11-4.12A	Silt Fence
11-4.12B	Silt Fence Detail
11-4.12C	Filter Barriers
11-4.13	Straw Bale Barrier
11-4.14A	Storm Drain Inlet Filter
11-4.14B	Storm Drain Inlet Filter Bag
11-4.14C	Inlet Sediment Control
11-4.16	Fiber Rolls
11-4.17	Concrete Washout
11-5.2.5A	Stormwater Quality Drop Inlet Concrete Stamps
11-5.2.5B	Drop Inlet Stamp Messages & Symbols

11-1 ABBREVIATIONS / ACRONYMS

BMP	Best Management Practice
CWA	Clean Water Act

General Permit	State Water Resources Control Board Order No. 00-08 – DWQ National Pollutant Discharge Elimination System General Permit # CAS000002
MCM	Minimum Control Measures
NOI	Notice of Intent
NOT	Notice of Termination
NPDES	National Pollutant Discharge Elimination System
NRCS	National Resource Conservation Service
RWQCB	Regional Water Quality Control Board
SWMP	Stormwater Management Plan
SWPPP	Storm Water Pollution Prevention Plan
SWRCB	State Water Resources Control Board
Wet Season	October 1 st through April 30 th
WPCP	Water Pollution Control Program

11-2 GOOD HOUSEKEEPING PRACTICES

All construction sites shall be required to follow these Good Housekeeping Practices regardless of the project size or number of square feet of soil disturbed.

- A. Definition – The BMPs that prevent pollutants from entering stormwater drainage systems or watercourses by limiting or reducing the potential at their source. Good Housekeeping Practices involve the day-to-day operations of the construction site, which involve keeping the site clean and orderly.
- B. Applicability – The deployment and implementation of Good Housekeeping Practices depends on the conditions and applicability described below:

11-2.1 All Construction Sites Regardless of Size

1. Identify all storm drains, drainage swales and creeks located near the construction site and make sure all subcontractors are aware of their locations to prevent pollutants from entering them.
2. Clean up and properly dispose of all leaks, drips, and other spills immediately.
3. Refuel vehicles and heavy equipment in one designated location or off-site if possible.

4. Wash vehicles at an appropriate off-site facility. If equipment must be washed on-site, do not use soaps, solvents, degreasers, or steam cleaning equipment, and prevent wash water from entering the storm drain or watercourse.
5. Never wash down pavement or surfaces where materials have spilled. Use dry cleanup methods whenever possible.
6. Avoid contaminating clean runoff from areas adjacent to your site by using berms and/or temporary or permanent drainage ditches to divert water flow around the site.
7. Keep materials out of the rain. Schedule clearing or heavy earth moving activities for periods of dry weather. Cover exposed piles of soil, construction materials and wastes with plastic sheeting or temporary roofs. Before it rains, sweep and remove materials from surfaces that drain to storm drains or watercourses.
8. Place trash cans around the site to reduce litter. Dispose of non-hazardous construction wastes in covered dumpsters or recycling receptacles. Recycle leftover materials whenever possible.
9. Dispose of all wastes properly. Materials that cannot be reused or recycled must be taken to an appropriate landfill or disposed of as hazardous waste.
10. Cover open dumpsters with plastic sheeting or a tarp during rainy weather if your dumpster does not have a cover. Secure the sheeting or tarp around the outside of the dumpster. If your dumpster has a cover, make sure it is closed and secured.
11. Train your employees and inform subcontractors about the stormwater requirements and their own responsibilities.
12. Locate portable toilets a minimum of 25 feet away from drain inlets, watercourses and traffic circulation. Portable toilets shall be secured to prevent overturning. Regular service and waste disposal shall be provided. Untreated raw wastewater should never be discharged or buried. Install a secondary containment around portable toilets adequate for handling spills during servicing.

11-2.2 Construction Projects Involving Paint Work

1. Non-hazardous paint chips and dust from dry stripping and sand blasting may be swept up or collected in plastic drop cloths and disposed of as trash.
2. Chemical paint stripping residue and chips and dust from marine paints or paints containing lead or tributyl tin must be disposed of as a hazardous waste.
3. When stripping or cleaning building exteriors with high-pressure water, cover or berm storm drain inlets and prevent discharge into watercourses. If possible (and allowed by the local wastewater treatment plant), collect (mop or vacuum) building cleaning water and discharge to the sanitary sewer, where allowed.

4. Never clean brushes, paint containers or equipment or allow rinse water to enter the street, gutter, storm drain, or watercourses.
5. For water-based paints, paint out brushes, or other painting equipment, to the extent possible and rinse to a drain leading to the sanitary sewer (i.e., indoor plumbing).
6. For oil-based paints, paint out brushes, or other painting equipment, to the extent possible, and filter and reuse thinners and solvents. Dispose of unusable thinners and residue as hazardous waste.
7. Recycle, return to supplier or donate unwanted water-based (latex) paint.
8. Dried latex paint may be disposed of in the garbage.
9. Unwanted oil-based paint (that is not recycled), thinners, and sludges must be disposed of as hazardous waste.

11-2.3 Construction Projects Involving Cement and Concrete Work

1. Avoid mixing excess amounts of fresh concrete or cement mortar on-site.
2. Store dry and wet materials under cover, protected from rainfall and runoff.
3. Wash out concrete transit mixers only in designated washout areas where the water will flow into settling ponds or onto dirt or stockpiles of aggregate base or sand. Pump water from settling ponds to the sanitary sewer, where allowed. Whenever possible, recycle washout by pumping back into mixers for reuse. Never allow washout to enter the street, storm drains, drainage ditches, or other watercourses.
4. Whenever possible, return contents of mixer barrel to the yard for recycling. Dispose of small amounts of dried excess concrete, grout, and mortar in the trash.

11-2.4 Construction Projects Involving Roadwork/Pavement Construction

1. Apply concrete, asphalt, and seal coats during dry weather to prevent contaminants from contacting stormwater runoff.
2. Cover storm drain inlets and manholes when paving or applying seal coats, slurry seal, fog seal, etc.
3. Always park paving machines over drip pans or absorbent materials, since they tend to drip continuously.
4. When making saw-cuts in pavement, use as little water as possible. Cover storm drain inlets completely with filter fabric during the sawing operation and contain the slurry by placing sandbags, gravel bags, gravel dams, or other approved BMP around the storm drain inlets. After the liquid drains or evaporates, shovel or vacuum the slurry residue from the pavement or gutter and dispose of it properly.

5. Wash down exposed aggregate concrete pavement only when the wash water can: (1) flow onto a dirt area; (2) drain onto a bermed surface from which it can be pumped and disposed of properly; or (3) be vacuumed from the area along the curb where sediment has accumulated by blocking a storm drain inlet.
 6. Allow aggregate rinse water to settle, and pump the water to the sanitary sewer if allowed by the local wastewater authority.
 7. Never wash sweepings from exposed aggregate concrete pavement into a street, storm drain, or watercourse. Collect and return to aggregate base stockpile, or dispose of it with the trash.
 8. Recycle broken concrete and asphalt.
- C. Design – Owners, contractors, and developers shall be vigilant regarding the implementation of these BMPs, including making them a part of all prime and subcontract agreements.
- D. Maintenance – Being vigilant regarding Good Housekeeping Practices could prevent an inadvertent violation, the imposition of fines, and project delays. If procedures are not implemented properly or if the BMPs are compromised, the stormwater discharge will then be subject to the sampling and analysis requirements contained in the General Permit Section B, “Monitoring Program and Reporting Requirements”.

11-3 CONSTRUCTION PROJECTS WITH SOIL DISTURBANCE OF AN ACRE OR MORE:

Construction activities that disturb one or more acres of land are required to comply with the Statewide National Pollutant Discharge Elimination System (NPDES) general permit that regulates stormwater leaving a construction site. Construction sites of less than one acre, but part of a larger project that covers one or more acres, regardless of phasing, must also comply. Construction activities that essentially maintain existing facilities, and do not involve a change in grade, are not required to comply with the General Permit.

- A. Definition – One acre of disturbed land is equivalent to the mathematical total of 43,560 square feet, regardless of geometric configuration. Disturbed land means any soil moved from its original location by any action or activity exposing it to rain runoff or wind erosion.
- B. Applicability – Construction activities subject to regulation include, but are not limited to:
 1. Clearing
 2. Grading

3. Stockpiling
4. Excavation

Construction activities not subject to regulation include, but are not limited to:

1. Routine maintenance
2. Emergency construction required to protect public health and safety

Dischargers should confirm with the local RWQCB that a routine maintenance or emergency construction activity is subject to the General Permit.

11-3.1 Notice of Intent From the Regional Water Quality Control Board

Discharger shall submit a Notice of Intent (NOI) to obtain coverage under the general permit.

11-3.2 Storm Water Pollution Prevention Plan

1. The general permit requires the discharger to develop and implement a Storm Water Pollution Prevention Plan (SWPPP), which specifies the Best Management Practices (BMPs) that will be used to prevent all construction pollutants from contacting storm water and with the intent of keeping all products of erosion from moving off site into receiving waters.
2. The discharger is to take every measure practicable to eliminate or reduce non-storm water from entering storm drainage systems or other watercourses.
3. The discharger is required to perform inspections of all BMPs before, during, and after a storm event.
4. A full copy of the SWPPP, along with other required documents, must be maintained at the job site until completion of the project and a Notice of Termination (NOT) has been filed with the RWQCB.

11-3.3 County Approval Prior to Project Commencement

1. County Stormwater Management approval must be received before the start of any construction work disturbing one or more acres of land or that is a part of a larger project that disturbs one or more acres of land.
2. To receive County approval all dischargers must submit a copy of their NOI and SWPPP to the County office and pay applicable fees.
3. County staff will review the SWPPP for completeness and any required changes or additional information will have to be submitted to the County before a grading or

building permit can be approved. The changes or additions must also be attached to the contractor's SWPPP that is kept at the project site.

- C. Design – The discharger is to develop and implement an adequate SWPPP for the particular aspects of the project. Appropriate BMPs must be carefully chosen and then properly installed, inspected, and maintained according to the approved standard designs.
- D. Maintenance – Follow all Good Housekeeping Practices; inspections and maintenance of BMPs is the key to a successful water pollution prevention system. Document all SWPPP training of personnel, BMP inspections, revisions and repairs done on the project and keep these reports with the SWPPP on the project job site.

11-4 STORMWATER POLLUTION PREVENTION BEST MANAGEMENT PRACTICES FOR CONSTRUCTION ACTIVITIES:

11-4.1 Construction Sequence Schedule

- A. Definition – A written plan developed to include sequencing of construction activities and the implementation of BMP's to control erosion and sedimentation.
- B. Applicability – Every construction project meeting the 1-acre project area disturbance threshold shall have proper sequencing of construction activities and the implementations of BMP's especially when soil is to be disturbed during the rainy season.
- C. Design – Consideration must be given to the local climate and to reducing the amount and duration disturbed soil is exposed to erosion from wind, rain, runoff, and vehicle tracking while construction activities are being performed.
 - 1. Outline all land disturbing activities throughout each phase of the project.
 - 2. List all BMP's necessary to control erosion and sedimentation during both the wet and dry seasons until project completion.
 - 3. Combine these lists to provide a practical and effective Construction Sequence Schedule.
- D. Maintenance – This is a dynamic-evolving schedule, allow room for alterations and updating as conditions change. Give due consideration to environmental constraints such as the nesting season of specific birds and the optimal times for seeding and re-vegetation.
 - 1. Inspect and verify that work is progressing in accordance with the schedule. If progress has deviated take corrective action.
 - 2. Amend the schedule to reflect changes in construction progress or critical path changes.

3. Amend the schedule prior to the rainy season to show updated information on the deployment and implementation of construction site BMP's.

11-4.2 Construction Site BMP's

Standard Improvement BMP's for use During Construction Projects:

1. Access points to the construction site shall be constructed in accordance with Stabilized Construction Access (Section 11-4.8).
2. Existing vegetation shall be preserved as directed in Preservation of Existing Vegetation (Section 11-4.5) and Silt Fence (Section 11-4.12).
3. Perimeter protection along property lines shall follow guidelines in Preservation of Existing Vegetation (Section 11-4.5), Hydroseeding (Section 11-4.6), and Silt Fence (Section 11-4.12).
4. Slopes greater than 3 percent shall be temporarily seeded and slopes greater than 3:1 (H:V) shall have Hydroseeding (Section 11-4.6), Straw Mulch and Hydraulic Mulching (Section 11-4.15), Fiber Rolls (Section 11-4.16), and Geotextiles, Mats, and Erosion Control Blankets (Section 11-4.11) installed as required by site conditions.
5. The toe of all slopes greater than 3:1 (H:V) shall have Silt Fence (Section 11-4.12) and/or Fiber Roll (Section 11-4.16) erosion and sediment control installed.
6. Disturbed soil areas behind the curb or back of walk shall be stabilized using Straw Mulch and Hydraulic Mulching (Section 11-4.15), Soil Binders (Section 11-4.7), or Geotextiles, Mats, and Erosion Control Blankets (Section 11-4.11) in conjunction with Hydroseeding (Section 11-4.6) and/or Top Soiling (Section 11-4.4). Surface treatments shall extend to the greater of 20 ft (6 m) or to the top of the slope.
7. Roadway Subgrades shall have Fiber Rolls (Section 11-4.16), Silt Fence (Section 11-4.12), or Sediment Trap (Section 11-4.9) erosion and sediment controls installed.
8. Dead-end streets, to be extended in the future, shall have Preservation of Existing Vegetation (Section 11-4.5), Top Soiling (Section 11-4.4), Hydroseeding (Section 11-4.6), Sediment Trap (Section 11-4.9) or other applicable BMP to minimize the transport of sediment onto or from the improved surface.
9. Projects that include detention basins shall have a Sediment Basin (Section 11-4.10).
10. Existing drainage inlets shall be protected from sediment-laden runoff using Inlet Sediment Control Barriers & Filters (Section 11-4.14). New or retrofit drainage inlets shall have a message stamp according to Concrete Stamp or Epoxied Placards (Section 11-5.2.5).

11. Use of temporary or portable sanitary and septic waste systems shall be treated or disposed of in accordance with state and local requirements. Temporary or portable toilets shall be located a minimum of 25 feet from drain inlets, watercourses and traffic circulation. A licensed hauler shall service and dispose of sanitary waste at frequencies great enough to insure the facility does not overflow.
12. Each construction site shall provide designated paint and waste disposal locations, as necessary, that comply with CASQA Construction Handbook Section 4-2, "Waste Management & Materials Pollution Control BMP's".
13. A BMP installation schedule shall be included with the Improvement Plans that follow Construction Sequence Schedule (Section 11-4.1) guidelines. The schedule shall include the BMP's for both the wet season and dry season.

Design information for BMP's is available from the following resources:

- A. Caltrans guidelines and handbooks available on line at:
<http://www.dot.ca.gov/hq/env/stormwater/special/newsetup/>
- B. Several publications from the State Water Resources Control Board's website at:
<http://www.swrcb.ca.gov/stormwtr/links.html>
- C. California Stormwater Quality Association's 2003 Stormwater Best Management Practice (BMP) Handbooks, which are available online at:
<http://www.cabmphandbooks.com>.
- D. National Resource Conservation Service Planning & Design Manual available online at
<http://www.wsi.nrcs.usda.gov/products/UrbanBMP's/water.html>.
- E. Additional sources of information can be found in the following:
 1. Storm Water Quality Task Force. 1993. California Storm Water Best Management Practice Handbook – Municipal.
 2. Storm Water Quality Task Force. 1993. California Storm Water Best Management Practice Handbook – Industrial / Commercial.
 3. Erosion and Sediment Control Field Manual prepared by California Regional Water Quality Control Board, San Francisco, Bay Region, 1997.
 4. Blueprint for a Clean Bay. "Best Management Practices to Prevent Storm Water Pollution from Construction-Related Activities", published by AASMAA and the Santa Clara Valley Non-point Source Pollution Control Program. 1995.

These resources do not constitute an exhaustive list. The BMP resources listed above are intended to assist the construction site and maintenance managers in selecting strategies for minimizing pollution. However, the County does not specifically endorse all or any of the

individual BMP's given in these guidelines, manuals and handbooks. Submit the selected BMPs to the County for approval.

11-4.3 Erosion and Sediment Control Plan

- A. Improvement Plans for all construction projects, regardless of the square feet of disturb land, shall include an Erosion and Sediment Control Plan, which shall comply with these standards.
- B. Erosion and Sediment Control Plans shall include erosion controls and sediment controls from this Chapter to minimize erosion and the transport of sediments. These plans may be incorporated into the Grading Plan, included in the project SWPPP, or submitted on separate sheets for clarity.
- C. Additionally, landowners meeting the 1-acre project area disturbance threshold shall comply with the requirements delineated in Section 11-3 of this Chapter prior to commencing construction activities. Coverage under the State's General Permit can be obtained by filing an NOI with the SWRCB including a vicinity map, developing a SWPPP, and paying the appropriate fee.

11-4.4 Top Soiling

- A. Definition – Salvaging, storing, and using the existing topsoil removed from active construction areas to enhance final site stabilization, infiltration and vegetation.
- B. Applicability – Top Soiling shall be considered as a cost effective measure on construction sites where there is a sufficient supply of quality topsoil that will be excavated during construction activities.
- C. Design – Determine whether the quality and quantity of available topsoil justifies selective handling. Quality topsoil has the following characteristics:
 - 1. Texture – loam, sandy loam, and silt loam are best; sandy clay loam, silty clay loam, clay loam, and loamy sand are fair. Do not use heavy clay and organic soils such as peat or muck as topsoil.
 - 2. Organic matter content – (sometimes referred to as “humic matter”) shall be greater than 1.0% by weight, but never more than 30% of total content.
 - 3. Acidity – pH should be greater than 3.6 before liming as required if the pH is less than 6.0.

Follow these Guidelines for Selective Handling of Top Soil:

- 1. Stripping – Strip topsoil only from those areas that will be disturbed by excavation, filling, road building, or compaction. Stripping depth shall be from 4-6 in. (102-152

- mm) depending on the site. Put sediment basins, diversions, and other controls into place before stripping.
2. Stockpiling – Select stockpile location to avoid slopes and natural drainageways, and to avoid traffic routes. On large sites, re-spreading is easier and more economical when topsoil is stockpiled in small piles located near areas where they will be used.
 3. Sediment Barriers – Use silt fences or other barriers where necessary to retain sediment.
 4. Scheduling – Follow the Construction Sequence Schedule for spreading the salvaged topsoil as soon as there permanent location is ready. Placing and stabilizing slopes and landscaped areas as construction progresses reduces runoff sedimentation and erosion and is cost effective as it reduces the use of more costly BMP's.
 5. Spreading Topsoil – Uniformly distribute topsoil to a minimum compacted depth of 2 in (51 mm) on no greater than a 3:1 (H:V) slopes and 4 in (102 mm) on flatter slopes.
- D. Maintenance – Where salvaged topsoil is to be stockpiled for more than 30 days protect it with temporary seeding as soon as possible. Use annual rye grass, winter wheat, or other fast-growing cover crop that will not become a problem plant. If the salvaged topsoil will be stockpiled for up to 12 months permanent vegetation shall be used to control erosion and weed growth. Sediment barriers shall be inspected and maintained throughout the time salvaged topsoil is stockpiled.

11-4.5 Preservation of Existing Vegetation

- A. Definition – The planned preservation of existing stable vegetated areas to reduce soil erosion and the amount of sediment in runoff water and to minimize the extent of disturbed area.
- B. Applicability – Sections of existing trees, shrubs, vines and grassy areas shall be preserved when existing vegetated area can be integrated into the proposed project on a temporary or permanent bases. Examples where preserving existing vegetation shall be applicable include, but not limited to:
 1. Buffer strips adjacent to wetlands and other sensitive areas.
 2. As perimeter protection along property lines.
 3. Undeveloped portions of a job site.
 4. Areas covered under local, state and federal government protection such as vernal pools, wetlands, marches and certain oak trees, etc.
 5. Vegetated areas designated for later removal that can be utilized temporarily for erosion control.

C. Design

1. Areas of vegetation to be preserved shall be clearly marked on Plans and fenced or flagged in the field.
2. Traffic and stockpiles shall be located away from vegetated areas. Any needed irrigation and maintenance shall be specified on the Plans.
3. For appropriate widths of vegetated area, refer to the specifications for Hydroseeding (Section 11-4.6).

D. Maintenance – Irrigation and maintenance requirements shall be specified on the Plans. Irrigation shall be provided as needed to maintain the vegetation year round.

11-4.6 Hydroseeding

A. Definition – The application of a mixture of fiber and stabilizing emulsion, with seed, and with fertilizer using hydro-mulch equipment, which temporarily protects exposed soils from erosion by wind and water.

B. Applicability – Hydroseeding shall be applied under the following conditions:

1. Graded or cleared areas subject to erosion from wind or water.
2. Disturbed area that will not have permanent stabilization.
3. Install hydroseeding in 20 ft (6 m) wide buffer strips at the back of walk or back of curb where sidewalks are detached or omitted, or to the top of slope at the pad.
4. Hydroseeding as perimeter control along property lines where established vegetation does not exist.
5. If slopes to be hydroseeded are steeper than 3:1 (H:V), hydroseeding shall be used in combination with matting, mulching, hydraulic mulching, or other soil stabilizer.

C. Design – Areas to be hydroseeded shall be clearly identified on the Plans.

Application shall conform to the following:

1. Timing – Hydroseeding shall be implemented in advance of the time when there is risk of erosion. To protect areas by October 1, hydroseeding shall be implemented no later than September 15. Hydroseeding applied after October 1 and before April 30 shall be covered with straw mulch, soil binder, or erosion control blanket/mat.
2. Adjacent to wetlands and environmentally sensitive areas, the minimum width of a vegetated area draining into the affected area shall be 100 ft (30 m) for slopes of 20:1 (H:V) or flatter. When slopes are steeper than 20:1 (H:V), additional measures shall

be used as determined by the Administrator. Adjacent to improvements, the minimum width shall be 20 ft (6 m).

D. Maintenance

1. All slopes shall be maintained to prevent erosion.
2. Seeded areas shall be inspected for failures and re-seeded, fertilized, and mulched within the planting season. Any temporary re-vegetation efforts that do not provide adequate cover must be re-vegetated as required by the Administrator.

11-4.7 Soil Binders

- A. Definition – The application and maintenance of polymeric or lignin sulfonate stabilizers or emulsions. Soil binders are materials applied to the soil surface to temporarily prevent wind or water-induced erosion of exposed soils.
- B. Applicability – Soil binders are applied to disturbed areas requiring short-term temporary protection.
- C. Design
1. Soil binders are temporary in nature and may need reapplication.
 2. Soil binders shall be applied a minimum of 24 hours prior to a rainfall event. Application during or immediately prior to rainfall will not be permitted.
 3. Soil binders shall be environmentally friendly (non-toxic to plant and animal life) and shall not stain or discolor paved or painted surfaces.
 4. Selection and application of soil binders shall be in accordance with the manufacturer’s recommendations and specifications.

11-4.8 Stabilized Construction Access

A stabilized construction site access is not required at sites where public streets or roads are unpaved.

- A. Definition – A stabilized access consisting of a pad of course aggregate underlain with filter cloth located where traffic enters or leaves a construction site to minimize a tracking of sediment from a construction site onto paved streets.
- B. Applicability – A stabilized construction access shall be applied at the following location where construction traffic enters or leaves:
1. Paved public streets, sidewalks and rights-of-way.

2. Parking lots or other paved areas.

C. Design

1. Placement of stabilized construction access shall be clearly defined on the Improvement Plans.
2. The stabilized construction site access shall be constructed per Drawing 11-4.8.
3. This practice shall be supported by a tire wash area and street sweeping or vacuuming. The Administrator may require a tire wash area where site conditions necessitate BMP measures beyond the stabilized construction access.

- D. Maintenance – Inspect stabilized construction access daily for damage and effectiveness of preventing soil, sediment, and construction debris from being tracked onto public streets. Streets adjacent to stabilized construction access shall be swept or vacuumed daily to remove loose materials.

11-4.9 Sediment Trap

- A. Definition – A small temporary basin formed by excavation to intercept and detain the sediment-laden runoff to allow the sediment to settle. It is used to protect other drainage facilities and properties downstream of the sediment trap.
- B. Applicability – There are two types of sediment traps:
1. Vegetated outlet traps suitable for drainage areas of less than 5 acres (2 hectares).
 2. Stabilized outlet traps, suitable for drainage areas from 5 to 10 acres (2 to 4 hectares).

Sediment traps shall ***not*** be applied under the following conditions:

1. The drainage area is greater than 10 acres (4 hectares).
2. In a creek or stream.
3. Uphill from a street or utility trench.
4. In areas subject to trespass.

C. Design

1. Placement of a sediment trap shall be clearly defined on the Plans.
2. Sediment traps shall be constructed as the first step when there is mass clearing or grading and shall be located at the point where drainage discharges from a site.
3. Construction of sediment traps shall be per Drawings 11-9A and 11-9B.

4. The sediment trap storage volume shall be designed for 35 cubic yards per acre (70 cubic meters per hectare) of contributing drainage area.
5. Side slopes shall be 3:1 (H:V) or flatter and the maximum depth shall be 3.5 ft (1.1 m).
6. The length of a sediment trap shall be 2 times (minimum) its width.

D. Maintenance

1. Trap maintenance shall be year round. Sediment material shall be removed from the bottom to retain one foot of capacity at all times.
2. Trap slopes shall be kept in good repair. Slope failures or damage shall be repaired promptly.

11-4.10 Sediment Basin

- A. Definition – A temporary basin formed by excavation to intercept and detain sediment-laden runoff to allow the sediment to settle. It is used to protect other drainage facilities and properties downstream of the sediment basin.
- B. Applicability – Sediment basins are suitable for incorporating into the construction of permanent facilities designed for flood control and water quality.

Sediment basins shall **not** be applied under the following conditions:

1. In a creek or stream.
 2. Where the project site can be broken up into small drainage areas (10 acres (4 hectares) or less) where sediment traps can be used.
 3. Where failure can cause property damage or loss of life.
 4. In areas subject to trespass unless they are secured.
- C. Design – Basins shall be located, sized and configured based on site-specific conditions. All basin designs are subject to approval by the Administrator. In addition to County Standards the sediment basins shall meet the minimum requirements of the State's General Construction Permit.
1. Basin sizing shall be in accordance with one of the three (3) options below:
 - a. Sediment basin(s), as measured from the bottom of the basin to the principal outlet, shall have at least a capacity equivalent to 133 cubic yards of storage per acre (267 cubic meters per hectare) draining into the sediment basin. The length of the basin shall be more than twice the width of the basin. The length is determined by measuring the distance between the inlet and outlet, and the depth

must not be less than 3 feet nor greater than 5 feet for safety reasons and for maximum efficiency.

- b. Sediment basin(s) shall be designed using the standard equation:

$$A_s = 1.2 Q/V_s$$

Where: A_s is the minimum surface area for trapping soil particles of a certain size; V_s is the settling velocity of the design particle size chosen; and $Q = C \times I \times A$ where Q is the discharge rate measured in cubic feet per second; C is the runoff coefficient; I is the intensity for the 10-year, 6-hour rain event and A is the area draining into the sediment basin in acres. The design particle size shall be the smallest soil grain size determined by wet sieve analysis, or the fine silt size (0.01 mm) particle, and the V_s used shall be 100 percent of the calculated settling velocity.

The length is determined by measuring the distance between the inlet and the outlet; the length shall be more than twice the dimension as the width; the depth shall not be less than 3 feet nor greater than 5 feet for safety reasons and for maximum efficiency (2 feet of storage, 2 feet of capacity). The basin(s) shall be located on the site where it can be maintained on a year round basis and shall be maintained on a schedule to retain the 2 feet of capacity.

- c. The use of an equivalent surface area design or equation, provided that the design efficiency is as protective of water quality than option b.
2. Construction of sediment basins shall be per Drawings 11-10A, 11-10B and 11-10C.
 3. The Administrator shall approve all Basins for drainage areas larger than 75 acres (30 hectares).
 4. Sediment basins shall be fenced where safety (worker or public) is a concern, or as indicated by the Administrator.

D. Maintenance

1. Basin maintenance shall be year round. Sediment material shall be removed from the bottom to retain 2 feet (0.61 meters) of capacity at all times.
2. Basin slopes shall be kept in good repair. Slope failures or damage shall be repaired promptly.
3. Basins shall have a means for dewatering within 7-calendar days follow a storm event.

11-4.11 Geotextiles, Mats, and Erosion Control Blankets

A. Definition – The placement of natural or synthetic geotextiles, plastic covers, or erosion control blankets/mats on the soil surface to stabilize disturbed areas and protect soils from erosion from wind, rain and water runoff. They may also be used to assist in the establishment of vegetation.

B. Applicability

1. Use these surface applications in conjunction with hydroseeding (Section 11-7) where slopes exceed 3:1 (H:V) or on exposed slopes when the timing is too late in the year for planting.
2. Use when disturbed soils may be difficult to stabilize with other BMP's.
3. Use as cover material and to protect soil stockpiles during rainfall events.
4. Use on channels to be vegetated.

Geotextiles, Mats, and Erosion Control Blankets shall *not* be applied in the following circumstances:

1. On excessively rocky sites.
2. For use with final phase vegetation if the vegetation is to be mowed.

C. Design – Areas where geotextiles, erosion blankets and matting are to be used shall be uniquely defined on the Plans.

1. Installation shall be in accordance with the manufacturers recommendation.
2. Geotextile material shall be woven polypropylene fabric with minimum thickness of 0.6 in (15 mm), minimum width of 12 ft (3.7 m) and shall have a minimum tensile strength of 0.67 kN (warp) and 0.36 kN (fill) in conformance with the requirements of ASTM Designation: D4632. The permittivity of the fabric shall be approximately 0.07 sec^{-1} in conformance with the requirements in ASTM Designation: D4491. The fabric shall have an ultraviolet (UV) stability of 70 percent in conformance with the requirements in ASTM Designation: D4355.
3. Geotextile blankets/mats shall be secured in place with wire staples or sandbags and by keying into tops of slopes to prevent infiltration of surface waters under geotextile material.
4. Plastic cover material shall be polyethylene sheeting and shall have a minimum thickness of 6 mils. Plastic covers shall be anchored by sandbags placed no more than 10 ft (3 m) apart and by keying into the tops of slopes to prevent infiltration of surface waters under the plastic. All seams shall be taped or weighted down their entire length, and there shall be as least a 12 in (300 mm) to 24 in (600 mm) overlap of all seams.

5. Erosion control blankets/mats shall be made of either straw, coconut, straw/coconut or excelsior blanket. Grade and shape the area of installation. Remove all rocks, clods, vegetation or other obstructions so that the installed blankets or mats will have complete, direct contact with the soil. Blankets/mats shall be anchored with U-shaped wire staples, metal geotextile stake pins or triangular wooden stakes. Staples shall be made of 0.12 in (3.05 mm) steel wire and shall be U-shaped with 7.9 in (200 mm) legs and a 2 in (50 mm) crown. Wire staples shall be minimum of 11 gauge. Metal stake pins shall be 0.2 in (5 mm) diameter steel with a 1.5 in (40 mm) steel washer at the head of the pin. Wire staples and metal pins shall be driven flush to the soil surface. All anchors shall be 6 in (150 mm) to 18 in (450 mm) long and have sufficient ground penetration to resist pullout.
6. Channels constructed during the wet season (October 1 through April 30) shall have the channel sides and bottom protected with erosion control blankets/mats as shown in Drawing 11-11A & 11-11B.
7. Channel bottoms shall be protected where the design channel flow exceeds 3 ft/sec (1 m/sec).

D. Maintenance

1. All blankets shall be inspected periodically after installation.
2. Inspect installations after significant rainfalls to check for erosion and undermining. Repair failures immediately. Damage to slopes or channels shall be repaired prior to reinstalling blankets/mats.

11-4.12 Silt Fence

- A. Definition – A barrier of extra strength filter fabric that has been entrenched and attached to supporting posts to reduce runoff velocity and detain sediment.
- B. Applicability – Silt fences are used near disturbed areas where sheet or rill flows occur and velocities are low. Silt fences are placed below the toe of exposed and erodible slopes, down-slope of exposed soil areas, around temporary stockpiles and along streams and channels.

Silt fences shall *not* be applied under the following conditions:

1. In the flowline of streams, channels, or anywhere flows are concentrated.
2. Drainage area of 1 acre (0.4 hectares) or more.
3. Where the slope is steeper than 2:1 (H:V).
4. Slopes that are subject to creep, slumping, or landslides.

5. Mid-slope installations where slope exceeds 4:1 (H:V).

C. Design

1. Placement of silt fences shall be clearly shown on the Plans.
2. Construction shall be per County of Yolo Standard Construction Specifications Drawing 11-12A, 11-12B and 11-12C.
3. The maximum slope length above the fence shall be no more than 30 ft (9 m) times the slope steepness expressed as a ratio. For example, a 4:1 (H:V) slope above a fence shall be no more than 120 ft (36 m). The maximum slope distance between silt fences, regardless of slope, shall be 200 ft (61 m).
4. The depth of flow shall be evenly distributed across the fence.
5. Silt fences shall be trenched in and the bottom of the fence fabric shall be keyed in.
6. The fence shall be placed on the contour and configured in the shape of a shallow arc with the ends uphill of the arc's center. It shall be constructed in a length sufficient to extend across the expected flow path.

D. Maintenance

1. Repair or replace split, torn, slumping or weathered fabric.
2. Inspect silt fences when rain is forecast and again after a rainfall event.
3. Sediment shall be removed from behind the silt fence when sediment accumulation is 1/3 the height of the barrier or when sediment accumulation is causing the silt fence to fail.

11-4.13 Straw Bale Barrier

- A. Definition – A barrier constructed with straw or hay bales across or at the toe of a slope to reduce runoff velocity and transport of sediment.

B. Applicability

Straw bale barriers shall **not** be applied in the following conditions:

1. Where concentrated flows occur.
2. On slopes steeper than 2:1 (H:V).

C. Design

1. Placement of straw bale barriers shall be clearly defined on the Plans.

2. Construction shall be per Drawing 11-13.
3. The maximum slope length above the barrier shall be no more than 30 ft (9 m) times the steepness expressed as a ratio. For example, the length of a 3:1 (H:V) slope above a barrier shall be no more than 90 ft (27 m). Bales shall be securely staked.
4. The depth of flow shall be evenly distributed across the barrier.
5. The barrier shall be placed on the contour and configured in the shape of a shallow arc with the ends uphill of the arc's center. It shall be constructed in a length sufficient to extend across the expected flow path.
6. Provision shall be made for an overflow in the event that the bales act as a dam and do not filter and disperse the flow.

11-4.14 Inlet Sediment Control Barriers & Filters

- A. Definition – A temporary sediment barrier placed in the gutter adjacent to, around, or suspended within a storm drain inlet to prevent sediment and debris from entering the storm drainage system.
- B. Applicability – Drop inlet protection is applicable after storm drain systems are installed. Inlet filter bags or inlet filters shall be installed at all drop inlets on new or existing streets within or downstream of the construction site.
- C. Design
 1. Sediment control devices shall be designed to allow maintenance of the device and regular removal of trapped sediments.
 2. Within traveled ways, vehicular and pedestrian, devices shall be selected and installed so that they do not constitute a hazard.
 3. Inlet sediment control devices may consist of gravel bags or other approved sediment control device, which provides effective sediment removal.
 4. Install per Drawing 11-4.14A, 11-4.14B and 11-4.14C.
 5. Inlet sediment control devices shall remain in place until soil-disturbing activities are completed and adjacent areas are stabilized.
- D. Maintenance
 1. Inlet sediment control devices shall be kept in good repair. Material spilling from sediment control devices shall be cleaned up and the device repaired or replaced immediately.

2. Inspection of devices shall be weekly and prior to predicted rainfall and after a rainfall event. Sediment removed from sediment control devices during maintenance operations shall be disposed of properly.
3. Trapped sediment and debris shall be removed from the inlet filter bag after each rainfall event.
4. Inlet filter bags having visible trapped water shall be maintained immediately.
5. Torn filter bags shall be removed and replaced.
6. Filter bags and frames shall be placed such that low flow surface water does not bypass the filter bag.

11-4.15 Straw Mulch and Hydraulic Mulching

- A. Definition – Placing a uniform layer of straw mulch and incorporating it into the soil with a studded roller or anchoring it with a tackifier. Or using a mixture of shredded wood fiber or a hydraulic matrix and a stabilizing emulsion or tackifier and spreading it by hydro-mulching equipment.
- B. Applicability – Straw mulch is used for temporary soil stabilization on disturbed areas until soils can be prepared for re-vegetation and permanent vegetation is established. Straw mulch is also used in temporary and permanent seeding strategies to enhance plant establishment.
- C. Design
 1. Straw shall be derived from wheat, rice, or barley.
 2. Straw mulch with tackifier shall not be applied during or immediately prior to rainfall.
 3. Tackifier is the preferred method for anchoring straw mulch to the soil on slopes. Crimping, punch roller-type rollers, or tack-walking may also be used.
 4. Apply loose straw at a minimum rate of 4,000 lb/ac (3,570 kg/ha).
 5. Apply tackifier at a minimum rate of 125 lb/ac (140 kg/ha).
 6. Areas to be covered using hydraulic mulching must be roughened using a rolling crimping or punching type roller or by track walking. Track walking shall only be used where other methods are impractical.
 7. Wood fiber mulch can be applied alone at the rate of 2,000 to 4,000 lbs/ac (1,785 to 3,570 kg/ha) or as a component of hydraulic matrices.

8. Hydraulic matrices include a mixture of wood fiber and acrylic polymer or other tackifier as a binder and applied as a liquid slurry using a hydraulic application equipment. The minimum rate of application shall be follow manufacturer's specification to achieve completer coverage of 2,000 to 4,000 lbs/ac (1,785 to 3,570 kg/ha), and 5 to 10% (by weight) of tackifier (acrylic copolymer, guar, psyllium, etc.).
9. Hydraulic matrices application requires 24 hours to dry before a rainfall event.

D. Maintenance

1. Maintain an unbroken temporary mulched ground cover throughout the period of construction when the soils are not being reworked.
2. Reapplication of straw mulch and tackifier may be required by the Administrator to maintain effective soil stabilization over disturbed areas and slopes.
3. Slopes shall be maintained and repaired immediately after any rainfall event.

11-4.16 Fiber Rolls

- A. Definition – A fiber roll consists of straw, flax, or other materials that are rolled and bound into a tight tubular roll and placed on the face of slopes at regular intervals or behind curbs and walkways to intercept storm water runoff, reduce its velocity, release the runoff as sheet flow, and provide some removal of sediment from the runoff.
- B. Applicability – Fiber rolls shall be used along the top, face and at grade breaks of exposed and erodible slopes, placed behind curbs or walkways, and used as check dams when properly anchored.
- C. Design
 1. On slopes fiber rolls shall be placed along the contour. At the ends of the row, the last 2 ft (0.6 m) shall be turned up slope slightly.
 2. Fiber rolls shall be manufactured and have a minimum density of 1.1 lbs/lf (1/6 kg/m). Use and installation of fiber rolls shall be in accordance with the manufacturer's recommendations.
 3. When more than one fiber roll is placed in a row, the ends of the rolls shall be butted together tightly, or overlapped a minimum of 1 ft (300 mm).
 4. Fiber rolls used as check dams shall be trenched and staked such that water is not allowed to flow under the rolls.
 5. Install per Drawing 11-4.16.

D. Maintenance

1. Repair or replace split, torn, unraveling, or slumping fiber rolls.
2. Inspect fiber rolls when rain is forecast.
3. In active construction areas where fiber rolls are removed during the workday, return or replace the fiber rolls to its proper place and stake them down at the end of each workday during the wet season.

11-4.17 Concrete Washouts

- A. Definition – Procedures and practices that are implemented to minimize or eliminate the discharge of concrete waste materials to the storm drain system or to watercourses.
- B. Applicability – Concrete washouts are to be placed on project sites where concrete is used as a construction material, where slurries containing Portland cement concrete (PCC) or asphalt concrete are generated, or where concrete trucks and other concrete-coated equipment are washed on site.
- C. Design
 1. Temporary concrete washout facilities shall be located a minimum of 50 ft (15 m) from storm drain inlets, open drainage facilities, and watercourses.
 2. A sign shall be installed adjacent to each washout facility to inform concrete equipment operators of its location. Signs shall be placed on construction sites providing direction to the concrete washout.
 3. Installation shall be per Drawing 11-4.17.
 4. Plastic lining material shall be a minimum of 60 mils polyethylene sheeting and shall be free of holes, tears or other defects that compromise the impermeability of the material.
 5. Concrete washouts constructed below grade shall have a minimum depth of 12 in (0.30 m) and have a surface area of 50 square feet (4.645 square meters).
- D. Maintenance
 1. Inspect concrete washouts daily.
 2. Concrete washouts shall be cleaned when the waste volume in the washout reaches 75% of capacity.

11-4.18 Clean Up

All temporary erosion and sediment control measures shall be cleaned up and removed by the Contractor upon completion of all improvements and after establishment of all permanent erosion and sediment control measures and/or permanent landscaping. As a portion of the temporary erosion and sediment control measures are no longer needed, they shall be cleaned up and removed from the project site. Any organic matter, such as partially decomposed straw bales, may be spread as mulch in landscaped areas at the discretion of the property owner. Any non-organic matter shall be removed from the project site and disposed of at a landfill or other recycling facility or hazardous material disposal center, as appropriate. Street washing is not allowed, as it sends tracked sediment down the storm drains or receiving waters.

11-4.19 Street Sweeping and Vacuuming

- A. Definition – Street sweeping and vacuuming includes use of self-propelled and walk-behind equipment to remove sediment from streets and roadways, and to clean paved surfaces in preparation for final paving. Sweeping and vacuuming prevents sediment from the project site that has been tracked onto the street surface from entering storm drains or receiving waters.
- B. Applicability – Sweeping and vacuuming are suitable anywhere sediment is tracked from the project site onto public or private paved streets and roads, typically at points of egress.
- C. Design
 - 1. Limit the number of points where vehicles can leave the project site to focus sweeping and vacuuming efforts.
 - 2. Inspect potential sediment tracking locations daily.
 - 3. Visible sediment tracking shall be swept or vacuumed on a daily basis.
 - 4. Do not use kick brooms or sweeper attachments. These tend to spread the dirt rather than remove it.
 - 5. If the removed sediment swept or vacuumed up is not mixed with debris or trash it may be incorporated back into the project at the owner's discretion.
 - 6. If tracked sediment is wet or caked on the paved surface it will need to be scraped loose prior to sweeping or vacuuming.
- D. Maintenance
 - 1. Inspect BMP's prior to forecast rain, daily during extended rain events, after rain events, weekly during the rainy season, and at two-week intervals during the non-rainy season for sources of potential sediment tracking.

2. When actively in use, points of ingress and egress must be inspected daily.
3. When tracked or spilled sediment is observed outside the construction limits, it must be removed daily. Tracked sediment removal shall be removed continuously during rain events if construction activities are being pursued.
4. Be careful not to sweep up any unknown substance or any object that may be potentially hazardous.
5. Adjust brooms frequently to maximize efficiency of sweeping operations.
6. After sweeping is finished, properly dispose of sweeper wastes at an approved dumpsite.

11-5 PERMANENT POST-CONSTRUCTION STORMWATER POLLUTION CONTROLS FOR NEW DEVELOPMENT OR REDEVELOPMENT PROJECTS

11-5.1 Project Categories Subject to these Design Standards:

All discretionary development or redevelopment projects that fall into one of the following categories are subject to these Improvement Standards. These categories are:

1. Single-family hillside residences
2. 100,000 square foot commercial developments
3. Automotive repair shops
4. Retail gasoline outlets
5. Restaurants
6. Home subdivisions occupying an acre or more
7. Parking lots 5,000 square feet or more or with 25 or more parking spaces and potentially exposed to storm water runoff

11-5.2 Design Standards Applicable to all Categories

11-5.2.1 Maintain Pre-Development Peak Stormwater Discharge Rates

Post-development peak storm water runoff discharge rates shall not exceed the estimated pre-development rate for developments where the increased peak storm water discharge rate will result in increased potential for downstream erosion.

11-5.2.2 Conserve Natural Areas

If applicable, the following items are required and must be implemented in the site layout during the subdivision design and approval process, consistent with applicable the County's General Plan policies:

1. Concentrate or cluster Development on portions of a site while leaving the remaining land in a natural undisturbed condition.
2. Limit clearing and grading of native vegetation at a site to the minimum amount needed to build lots, allow access, and provide fire protection.
3. Maximize trees and other vegetation at each site by planting additional vegetation, clustering tree areas, and promoting the use of native and/or drought tolerant plants.
4. Promote natural vegetation by using parking lot islands and other landscaped areas.
5. Preserve riparian areas and wetlands.

11-5.2.3 Minimize Stormwater Pollutants of Concern

Pollutants of concern consist of any pollutants that exhibit one or more of the following characteristics: current loadings or historic deposits of the pollutant are impacting the beneficial uses of a receiving water, elevated levels of the pollutant are found in sediments of a receiving water and/or have the potential to bioaccumulate in organisms therein, or the detectable inputs of the pollutant are not at concentrations or loads considered potentially toxic to humans and/or flora and fauna.

1. Oil and Grease
2. Suspended Solids and Metals
3. Gasoline
4. Pesticides
5. Pathogens

11-5.2.3 Protect Slopes and Channels

Project plans must include BMPs consistent with Yolo County codes and Ordinances, and other regulatory mechanisms and these Improvement Standards aimed at decreasing the potential of slopes and/or channels from eroding and impacting stormwater runoff:

1. Convey runoff safely from the tops of slopes and stabilize disturbed slopes.
2. Utilize natural drainage systems to the maximum extent practicable.
3. Stabilize permanent channel crossings.

4. Vegetate slopes with native or drought tolerant vegetation, as appropriate.
5. Install energy dissipaters, such as riprap, where appropriate to minimize erosion, with the approval of all agencies with jurisdiction, e.g., the U.S. Army Corps of Engineers and the California Department of Fish and Game.

11-5.2.5 Concrete Storm Drain System Stamp or Epoxied Placards

Developers shall install the Yolo County standard storm drain stencil or sign at the public access points to storm drain, channels, creeks, or other watercourses within the project area as described under the following specification

- A. Definition – A message stamped into the concrete or cast into any cast iron framework at each storm drain drop inlet to alert citizens not to dump into the storm drainage system. Or in the case of a storm drain drop inlet retro-fix project a placard containing the same message epoxied to the top of the drop inlet.
- B. Applicability – Concrete stamps shall be applied at all new or reconstructed storm drain inlets. Placards shall be applied to retrofitted storm drain inlets as required.
- C. Design
 1. Administrator shall approve all concrete stamps and placards before being installed.
 2. Installation shall be per Drawing 11-5.2.5A and 11-5.2.5B.

11-5.2.6 Outdoor Material Storage Areas

Outdoor material storage areas refer to storage areas or storage facilities solely for the storage of materials. Improper storage of materials outdoors may provide an opportunity for toxic compounds, oil and grease, heavy metals, nutrients, suspended solids, and other pollutants to enter the storm water conveyance system or other watercourses. Where proposed project plans include outdoor areas for storage of materials that may contribute pollutants to the storm water conveyance system or watercourses, the following Structural or Treatment Control BMPs are required:

1. Materials with the potential to contaminate stormwater must be: 1) placed in an enclosure such as, but not limited to, a cabinet, shed, or similar structure that prevents contact with storm water runoff or spillage to the stormwater conveyance system or watercourses; or 2) protected by secondary containment structures such as berms, dikes, or curbs.
2. The storage area must be paved and sufficiently impervious to contain leaks and spills.
3. The storage area must have a roof or awning to minimize collection of stormwater within the secondary containment area.

11-5.2.7 Trash Storage Areas

A trash storage area refers to an area where a trash receptacle or receptacles (dumpsters) are located for use as a repository for solid wastes. The forces of water or wind can easily transport loose trash and debris into nearby storm drain inlets, channels, and other watercourses. All trash container areas must meet the following Structural and Treatment Control BMP requirements (individual single family residences are exempt from these requirements):

1. Trash container areas must have drainage from adjoining roofs and pavement diverted around the area(s).
2. Trash container areas must be screened or walled to prevent off-site transport of trash.

11-5.2.8 Ongoing BMP Maintenance

As a part of a project review, if a project applicant has included or is required to include, Structural or Treatment Control BMPs in project plans, it is required that the applicant provide verification of maintenance provisions through such means as may be appropriate, including, but not limited to legal agreements, covenants, CEQA mitigation requirements and /or Conditional Use Permits.

For all properties, the verification will include the developer's signed statement, as part of the project application, accepting responsibility for all Structural and Treatment Control BMP maintenance until the time the property is transferred and , where applicable, a signed agreement from the public entity assuming responsibility for Structural or Treatment Control BMP maintenance. The transfer of property to a private or public owner must have conditions requiring the recipient to assume responsibility for maintenance of any Structural or Treatment Control BMPs to be included in the sales or lease agreement for that property, and will be the owner's responsibility. The condition of transfer shall include a provision that the property owners conduct maintenance inspection of all Structural or Treatment Control BMPs at least once a year and retain proof of inspection. For residential properties where the Structural or Treatment Control BMPs are located within a common area, which will be maintained by a homeowner's association, language regarding the responsibility for maintenance must be included in the project's conditions, covenants and restrictions (CC & Rs). Printed educational materials will be required to accompany the first deed transfer to highlight the existence of the requirement and to provide the first deed transfer to highlight the existence of the requirement and to provide information on what storm water management facilities are present, signs that maintenance is needed, how the necessary maintenance can be preformed, and assistance that the County can provide. The transfer of this information shall also be required with any subsequent sale of the property.

If Structural or Treatment Control BMPs are located within a public area proposed for transfer, they will be the responsibility of the developer until they are accepted for transfer by the County or other appropriate public agency. Structural or Treatment Control BMPs proposed for transfer must meet design standards adopted by the public entity for the BMP

installed and should be approved by the County or other appropriate public agency prior to its installation.

11-5.2.9 Structural or Treatment Control BMPs

Yolo County requires that post-construction Treatment Control BMPs incorporate, at minimum, either a volumetric or flow based treatment control design standard, or both, as identified below to mitigate (infiltrate, filter or treat) storm water runoff:

1. Volumetric Treatment Control BMP

- a. The 85th percentile 24-hour runoff event determined as the maximized capture storm water volume for the area, from the formula recommended in Urban Runoff Quality Management, WEF Manual of Practice No. 23/ASCE Manual of Practice No. 87, (1998); or
- b. The volume of annual runoff based on unit basin storage water quality volume, to achieve 80 percent or more volume treatment by the method recommended in California Stormwater Best Management Practices Handbook – Industrial/Commercial, (2003); or
- c. The volume of runoff produced from a historical-record based reference 24-hour rainfall criterion for “treatment” that achieves approximately the same reduction in pollutant loads achieved by the 85th percentile 24-hour runoff event.

2. Flow Based Treatment Control BMP

- a. The flow of runoff produced from a rain event equal to at least two times the 85th percentile hourly rainfall intensity for the area; or
- b. The flow of runoff produced from a rain event that will result in treatment of the same portion of runoff as treated using the volumetric standards above.

Limited Exclusion:

Restaurants and Retail Gasoline Outlets, where the land area for development or redevelopment is less than 5,000 square feet, are excluded from the numerical Structural or Treatment Control BMP design standard requirement only.

11-5.3 Design Standards Applicable to Individual Priority Project Categories

11-5.3.1 100,000 Square Foot Commercial Developments

1. Properly Design Loading/Unloading Dock Areas

Loading/Unloading dock areas have the potential for material spills to be quickly transported to the stormwater conveyance system or watercourses. To minimize this potential, the following design criteria are required:

- a. Cover loading dock areas or design drainage to minimize run-on and runoff of stormwater.
- b. Direct connections to storm drains from depressed loading docks (truck wells) are prohibited.

2. Properly Design Repair/Maintenance Bays

Oil and grease, solvents, car battery acid, coolant and gasoline from repair/maintenance bays can negatively impact stormwater if allowed to come into contact with stormwater runoff. Therefore, design plans for repair bays must include the following:

- a. Repair/maintenance bays must be indoors or designed in such a way that doesn't allow stormwater run-on or contact with stormwater runoff.
- b. Design a repair/maintenance bay drainage system to capture all wash-water, leaks and spills. Connect drains to a sump for collection and disposal. Direct connection of the repair/maintenance bays to the storm drain system is prohibited.

3. Properly Design Vehicle/Equipment Wash Areas

The activity of vehicle/equipment washing/steam-cleaning has the potential to contribute metals, oil and grease, solvents, phosphates, and suspended solids to the stormwater conveyance system or watercourses. Include in the project plans an area for washing/steam-cleaning of vehicles and equipment. The area in the site design must be:

- a. Self-contained, equipped with grease trap, and properly connected to a sanitary sewer.
- b. If the wash area is to be located outdoors, it must be covered, paved, have secondary containment, and be connected to the sanitary sewer or other appropriately permitted disposal facility.

11-5.3.2 Restaurants

1. Properly Design Equipment/Accessory Wash Areas

The activity of outdoor equipment/accessory washing/steam-cleaning has the potential to contribute metals, oil and grease, solvents, phosphates, and suspended solids to the stormwater conveyance system or watercourses. Include in the project plans an area for the washing/steam-cleaning of equipment and accessories. This area must be:

- a. Self-contained, equipped with a grease trap, and properly connected to a sanitary sewer.
- b. If the wash area is to be located outdoors, it must be covered, paved, have secondary containment, and be connected to the sanitary sewer or other appropriately permitted disposal facility.

11-5.3.3 Retail Gasoline Outlets

1. Properly Design Fueling Area

Fueling areas have the potential to contribute oil and grease, solvents, car battery acid, coolant and gasoline to the stormwater conveyance system or watercourse. The project plans must include the following BMPs:

- a. The fuel dispensing area must be covered with an overhanging roof structure or canopy. The canopy's minimum dimensions must be equal to or greater than the area within the grade break. The canopy must not drain onto the fuel dispensing area, and the canopy downspouts must be routed to prevent drainage across the fueling area.
- b. The fuel dispensing area must be paved with Portland cement concrete (or equivalent smooth impervious surface), and the use of asphalt concrete shall be prohibited.
- c. The fuel dispensing area must have a 2% to 4% slop to prevent ponding, and must be separated from the rest of the site by a grade break that prevents run-on of stormwater to the extent practicable.
- d. At a minimum, the concrete fuel dispensing area must extend 6.5 feet (2.0 meters) from the corner of each fuel dispenser, or the length at which the hose and nozzle assembly may be operated plus 1 foot (0.3 meter), whichever is less.

11-5.3.4 Automotive Repair Shops

1. Properly Design Fueling Area

Fueling areas have the potential to contribute oil and grease, solvents, car battery acid, coolant and gasoline to the stormwater conveyance system and watercourses. Therefore, design plans, which include fueling areas, must contain the following BMPs:

- a. The fuel dispensing area must be covered with an overhanging roof structure of canopy. The canopy's minimum dimensions must be equal to or grater than the area within the grade break. The canopy must not drain onto the fuel dispensing area, and the canopy downspouts must be routed to prevent drainage across the fueling area.

- b. The fuel dispensing area must be paved with Portland cement concrete (or equivalent smooth impervious surface), and the use of asphalt concrete shall be prohibited.
- c. The fuel dispensing area must have a 2% to 4% slope to prevent ponding, and must be separated from the rest of the site by a grade break that prevents run-on of stormwater to the extent practicable.
- d. At a minimum, the concrete fuel dispensing area must extend 6.5 feet (2.0 meters) from the corner of each fuel dispenser, or the length at which the hose and nozzle assembly may be operated plus 1 foot (0.3 meter), whichever is less.

2. Properly Design Repair/Maintenance Bays

Oil and grease, solvents, car battery acid, coolant and gasoline from the repair/maintenance bays can negatively impact stormwater if allowed to come into contact with stormwater runoff. Therefore, design plans for repair bays must include the following:

- a. Repair/maintenance bays must be indoors or designed in such a way that doesn't allow stormwater run-on or contact with stormwater runoff.
- b. Design a repair/maintenance bay drainage system to capture all wash-water, leaks and spills. Connect drains to a sump for collection and disposal. Direct connection of the repair/maintenance bays to the stormwater system is prohibited. If direct connection with a city sanitary sewer, it is required that a Industrial Waste Discharge Permit be obtained by that jurisdiction.

3. Properly Design Vehicle/Equipment Wash Areas

The activity of vehicle/equipment washing/steam cleaning has the potential to contribute metals, oil and grease, solvents, phosphates, and suspended solids to the stormwater conveyance system and watercourses. Include in the project plans an area for washing/steam cleaning of vehicles and equipment. This area must be:

- a. Self-contained and/or covered, equipped with a clarifier, or other pretreatment facility, and properly connected to a sanitary sewer or other appropriately permitted disposal facility.

4. Properly Design Loading/Unloading Dock Areas

Loading/unloading dock areas have the potential for material spills to be quickly transported to the stormwater conveyance system or watercourses. To minimize this potential, the following design criteria are required:

- a. Cover loading dock areas or design drainage to minimize run-on and runoff of stormwater.

- b. Direct connections to storm drains from depressed loading docks (truck wells) are prohibited.

11-5.3.5 Parking Lots

1. Properly Design Parking Area

Parking lots contain pollutants such as heavy metals, oil and grease, and polycyclic aromatic hydrocarbons that are deposited on parking lot surfaces by motor vehicles. These pollutants are directly transported to surface waters. To minimize the offsite transport of pollutants, the following design criteria are required:

- a. Reduce impervious land coverage of parking areas.
- b. Infiltrate or treat runoff.

2. Properly Design to Limit Oil Contamination and Perform Maintenance

Parking lots may accumulate oil, grease, and water insoluble hydrocarbons from vehicle drippings and engine system leaks:

- a. Treat to remove oil and petroleum hydrocarbons at parking lots that are heavily used (e.g. fast food outlets, lots with 25 or more parking spaces, sports event parking lots, shopping malls, grocery stores, discount warehouse stores).
- b. Ensure adequate operation and maintenance of treatment systems particularly sludge and oil removal, and system fouling and plugging prevention control.

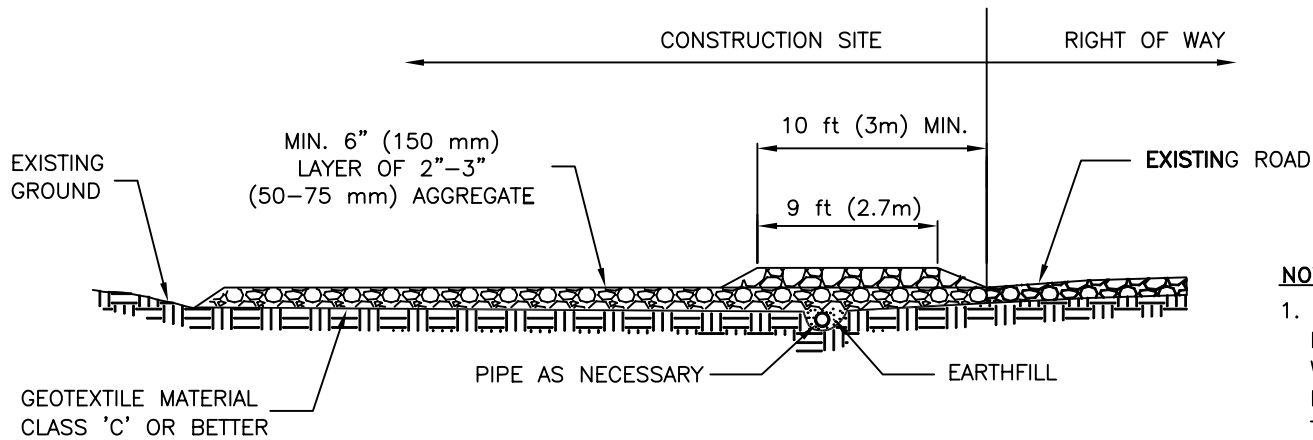

**CONSTRUCTION ENTRANCE/EXIT
SECTION VIEW A-A**

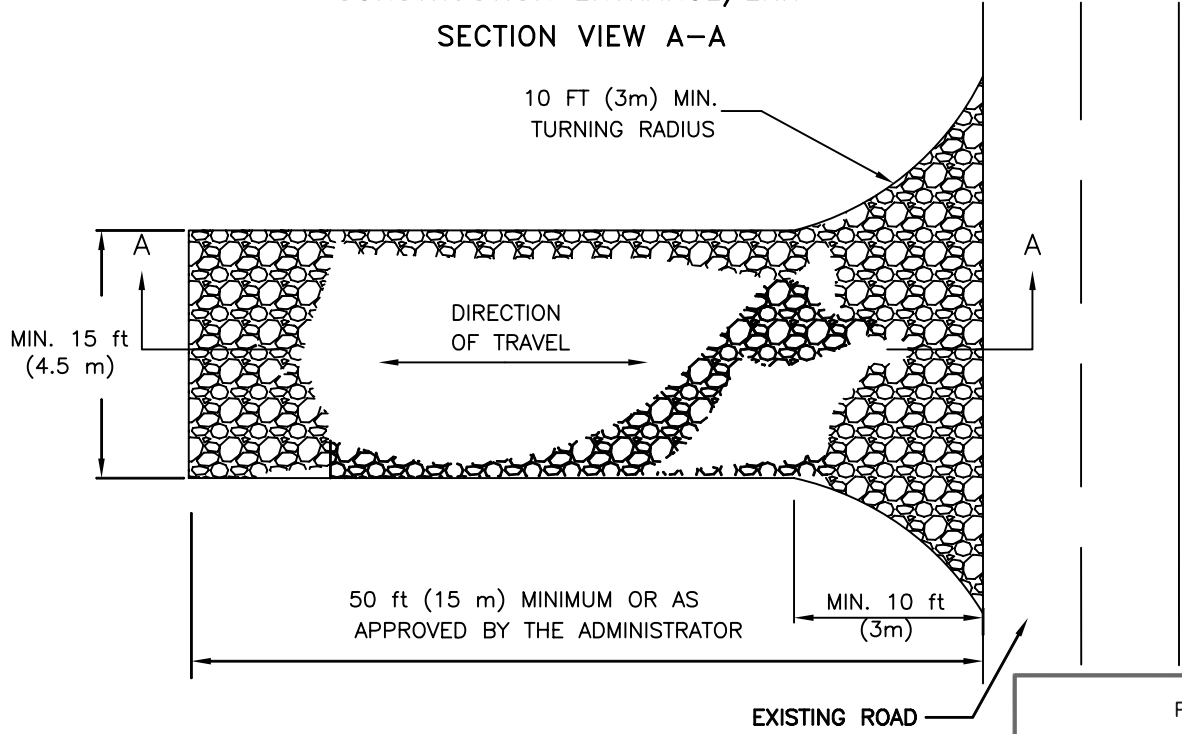

**CONSTRUCTION ENTRANCE/EXIT
PLAN VIEW**

NOTES:

1. STABILIZED CONSTRUCTION SITE ACCESS SHALL BE CONSTRUCTED OF 3"-6" (75-150 mm) WASHED, WELL GRADED GRAVEL OR CRUSHED ROCK. MATERIAL SHALL BE PLACED TO A MINIMUM THICKNESS OF 6" (150 mm).
2. LENGTH OF ENTRANCE SHALL BE A MINIMUM OF 50 ft (15 m). WIDTH SHALL BE A MINIMUM OF 15 ft (4.5 m) OR GREATER IF NECESSARY TO COVER ALL VEHICULAR INGRESS AND EGRESS. PROVIDE AMPLE TURNING RADII.
3. THE ENTRANCE SHALL BE KEPT IN GOOD CONDITION BY OCCASIONAL TOP DRESSING WITH MATERIAL AS SPECIFIED IN NOTE 1.
4. ACCESSES SHALL BE INSPECTED WEEKLY DURING PERIODS OF HEAVY USAGE, MONTHLY DURING NORMAL USAGE, AND AFTER EACH RAINFALL, WITH MAINTENANCE PROVIDED AS NECESSARY. PERIODIC TOP DRESSING SHALL BE DONE AS NEEDED.

COUNTY OF YOLO PLANNING, RESOURCES AND PUBLIC WORKS DEPARTMENT		DATE: 03/16/06
STABILIZED CONSTRUCTION SITE ACCESS		SHEET # 1 OF 1
COUNTY ENGINEER R.C.E. C-56781	APPROVAL DATE	11-4.8

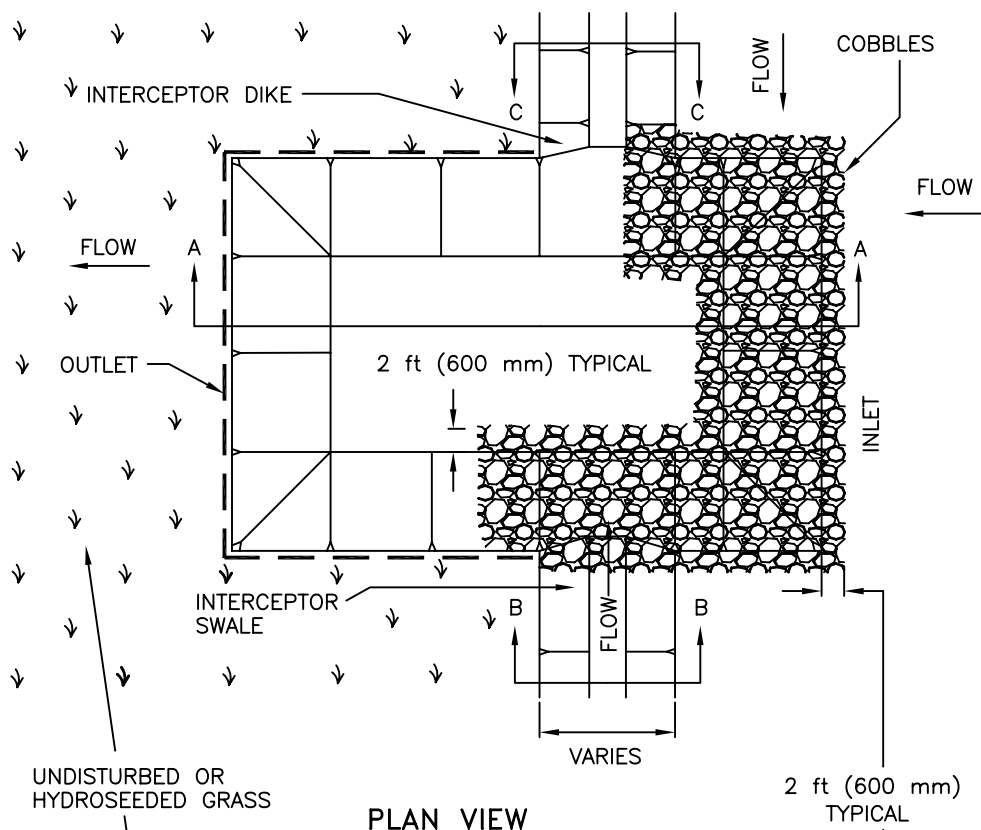

PLAN VIEW

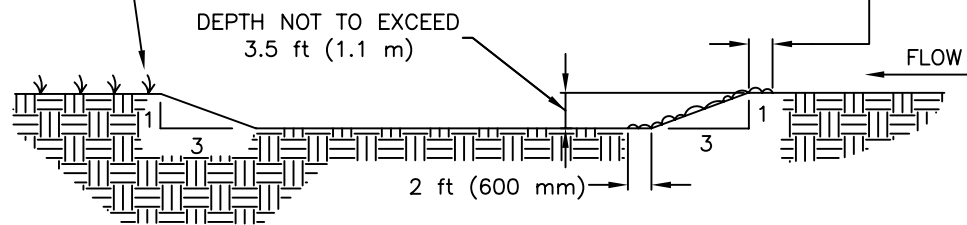

SECTION A-A

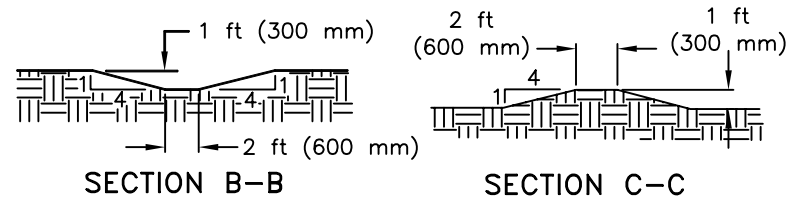

SECTION B-B

SECTION C-C

NOTES:

1. DIMENSIONS OF SEDIMENT TRAPS, DIKES, AND SWALES SHALL BE APPROVED BY THE ADMINISTRATOR.
2. INTERCEPTION DIKES AND SWALES SHALL BE CONSTRUCTED TO DRAIN SURFACE RUNOFF INTO SEDIMENT TRAPS.
3. TRAPS SHALL BE EXCAVATED WITH APPROPRIATE EQUIPMENT, TAKING CARE NOT TO DISTURB VEGETATION OR SOIL AT OUTLET CREST. SIDE SLOPES SHALL BE 3:1 OR FLATTER. MAXIMUM TRAP DEPTH SHALL BE 3.5 ft (1.1 m).
4. COBBLES CONFORMING TO STATE STANDARD SPECIFICATIONS SHALL BE PLACED ON THE TOPS, SLOPES, AND BOTTOMS OF THE INLET SIDES. COBBLES SHALL EXTEND A MINIMUM OF 2 ft (600 mm) BEYOND THE TOP AND TOE OF SLOPES.
5. PERIMETER OF THE SEDIMENT TRAP SHALL BE HYDROSEEDED 10 ft (3 m) BEYOND EDGE OF EXCAVATION IF EXISTING VEGETATION IS THIN, DISTURBED, OR NONEXISTENT.
6. THE CONTRACTOR SHALL INSPECT SEDIMENT TRAPS WEEKLY AND AFTER EACH RAINFALL AND REPAIR AS NECESSARY. SEDIMENT SHALL BE REMOVED FROM THE BOTTOM OF THE TRAP BEFORE IT REACHES 1 ft (300 mm) DEEP AND DISPOSE OF PROPERLY.
7. THIS SEDIMENT TRAP SHALL BE USED WHEN THERE IS NO EXISTING DOWNSTREAM DRAINAGE COURSE, OR WHEN IT IS DESIRABLE TO KEEP ALL RUNOFF WATER WITHIN CONSTRUCTION BOUNDARIES.

COUNTY OF YOLO PLANNING, RESOURCES AND PUBLIC WORKS DEPARTMENT	DATE: 03/16/06
SEDIMENT TRAP VEGETATED OUTLET	SHEET # 1 OF 2
COUNTY ENGINEER R.C.E. C-56781	APPROVAL DATE 11-4.9A

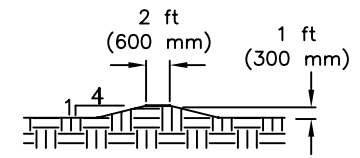
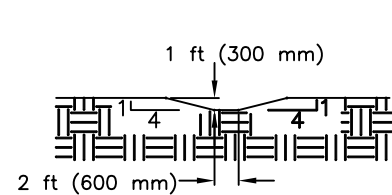
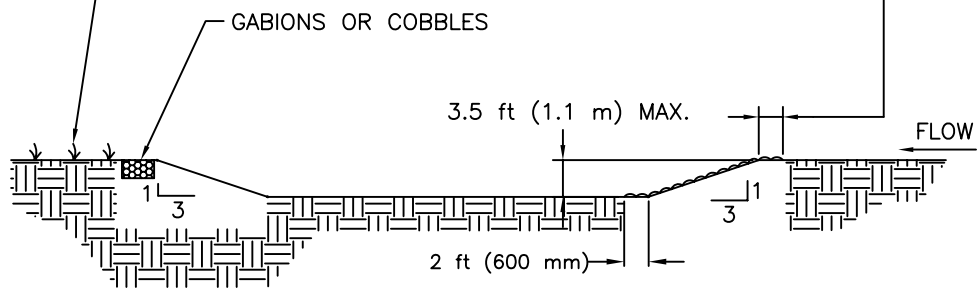
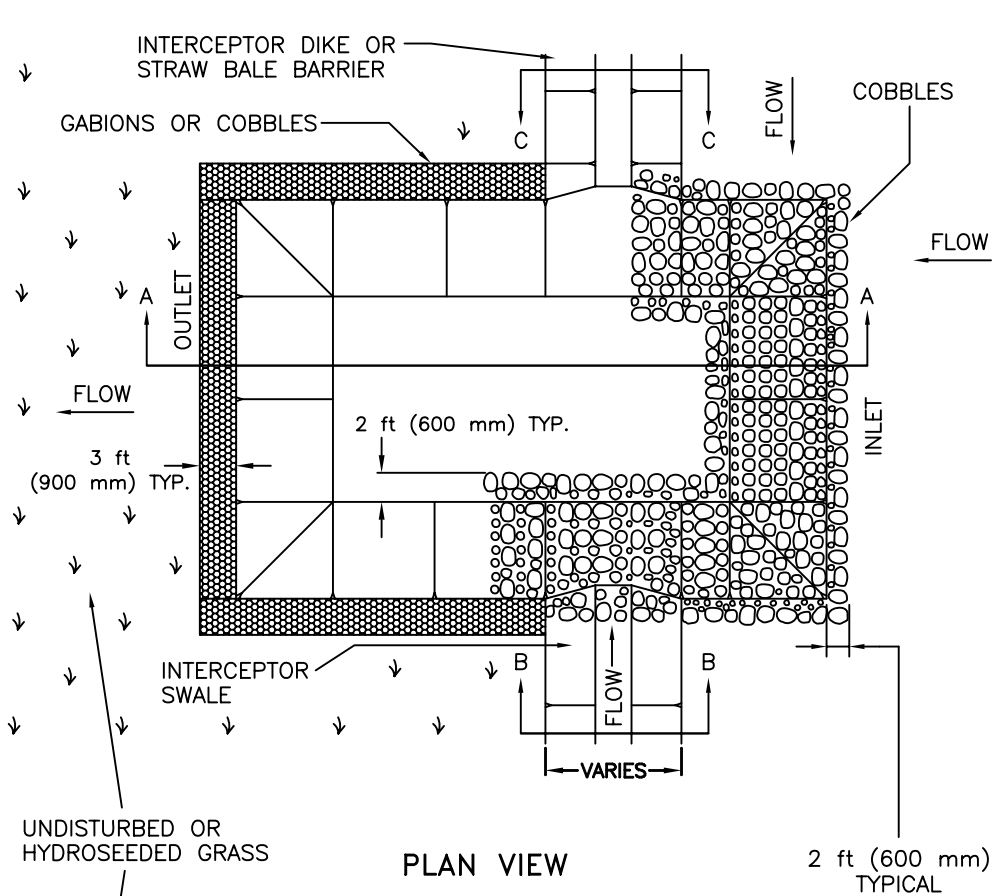

NOTES:

1. DIMENSIONS OF SEDIMENT TRAPS, DIKES, AND SWALES SHALL BE APPROVED BY THE ADMINISTRATOR.
2. INTERCEPTION DIKES AND SWALES SHALL BE CONSTRUCTED TO DRAIN SURFACE RUNOFF INTO SEDIMENT TRAPS.
3. TRAPS SHALL BE EXCAVATED WITH APPROPRIATE EQUIPMENT, TAKING CARE NOT TO DISTURB VEGETATION OR SOIL AT OUTLET CREST. SIDE SLOPES SHALL BE 3:1 OR FLATTER. MAXIMUM TRAP DEPTH SHALL BE 3.5 ft (1.1 m).
4. COBBLES CONFORMING TO STATE STANDARD SPECIFICATIONS SHALL BE PLACED ON THE TOPS, AND BOTTOMS OF THE INLET SIDES. COBBLES SHALL EXTEND A MINIMUM OF 2 ft (600 mm) BEYOND THE TOP AND TOE OF SLOPES.
5. PERIMETER OF SEDIMENT TRAPS SHALL BE STABILIZED WITH GABIONS OR COBBLES AND HYDROSEEDED 10 ft (3 m) BEYOND EDGE OF EXCAVATION IF EXISTING VEGETATION IS THIN, DISTURBED NONEXISTENT.
6. THE CONTRACTOR SHALL INSPECT SEDIMENT TRAPS WEEKLY AND AFTER EACH RAINFALL AND REPAIR AS NECESSARY. SEDIMENT SHALL BE REMOVED FROM THE BOTTOM OF THE TRAP BEFORE IT REACHES 1 ft (300 mm) DEEP, AND DISPOSE OF PROPERLY.
7. THIS SEDIMENT TRAP SHALL BE USED WHEN THERE IS NO EXISTING DOWNSTREAM DRAINAGE COURSE, OR WHEN IT IS DESIRABLE TO KEEP ALL RUNOFF WATER WITHIN CONSTRUCTION BOUNDARIES.

COUNTY OF YOLO PLANNING, RESOURCES AND PUBLIC WORKS DEPARTMENT	DATE: 03/16/06
SEDIMENT TRAP STABILIZED OUTLET	SHEET # 2 OF 2
COUNTY ENGINEER R.C.E. C-56781	APPROVAL DATE 11-4.9B

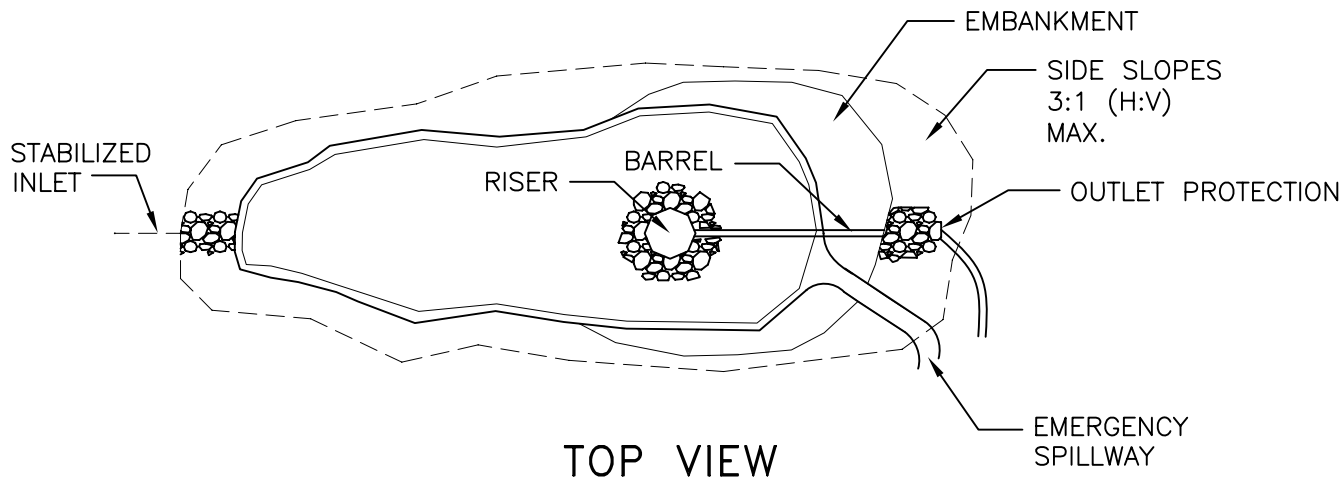

TOP VIEW

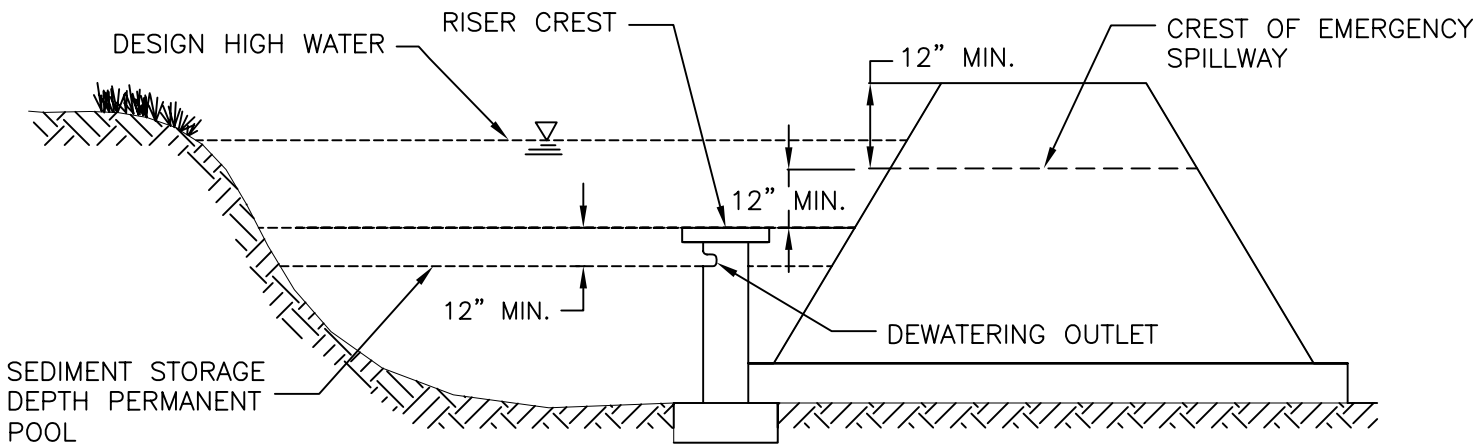

SIDE VIEW

NOTE:

1. THIS OUTLET PROVIDES NO DRAINAGE FOR PERMANENT POOL.
2. CONSTRUCT BEFORE CLEARING AND GRADING WORK BEGINS, WHEN FEASIBLE.
3. DO NOT LOCATE IN AN UNDISTURBED STREAM OR OTHER WATERCOURSE.
4. BASIN SITES SHOULD BE LOCATED WHERE FAILURE OF THE STRUCTURE WILL NOT CAUSE LOSS OF LIFE, DAMAGE TO HOMES OR BUILDINGS, OR INTERRUPTION OF USE OR SERVICE OF PUBLIC ROADS OR UTILITIES.
5. LARGE BASINS ARE SUBJECT TO STATE AND LOCAL DAM SAFETY REQUIREMENTS.
6. LIMIT THE CONTRIBUTING AREA TO ONLY THE RUNOFF FROM DISTURBED SOIL AREAS.
7. THE BASIN SHOULD BE LOCATED:
 - A. BY EXCAVATING A SUITABLE AREA OR WHERE LOW EMBANKMENT CAN BE CONSTRUCTED ACROSS A SWALE,
 - B. WHERE POST-CONSTRUCTION (PERMANENT) DETENTION BASINS WILL BE CONSTRUCTED, AND
 - C. WHERE THE BASIN CAN BE MAINTAINED ON A YEAR-ROUND BASIS TO PROVIDE ACCESS FOR MAINTENANCE INCLUDING SEDIMENT REMOVAL AND SEDIMENT STOCKPILING IN A PROTECTED AREA, AND TO MAINTAIN THE REQUIRED STORMWATER CAPACITY.

COUNTY OF YOLO PLANNING, RESOURCES AND PUBLIC WORKS DEPARTMENT	DATE: 03/16/06
TYPICAL TEMPORARY SEDIMENT BASIN SINGLE ORIFICE DESIGN	SHEET # 1 OF 3
COUNTY ENGINEER R.C.E. C-56781	APPROVAL DATE 11-4.10A

11-4.10B	COUNTY ENGINEER R.C.E. C-56781
DRAWING #:	APPROVAL DATE
SHEET # 2 OF 3	TYPICAL TEMPORARY SEDIMENT BASIN MULTIPLE ORIFICE DESIGN
DATE: 03/16/06	COUNTY OF YOLO PLANNING, RESOURCES AND PUBLIC WORKS DEPARTMENT

SIDE VIEW

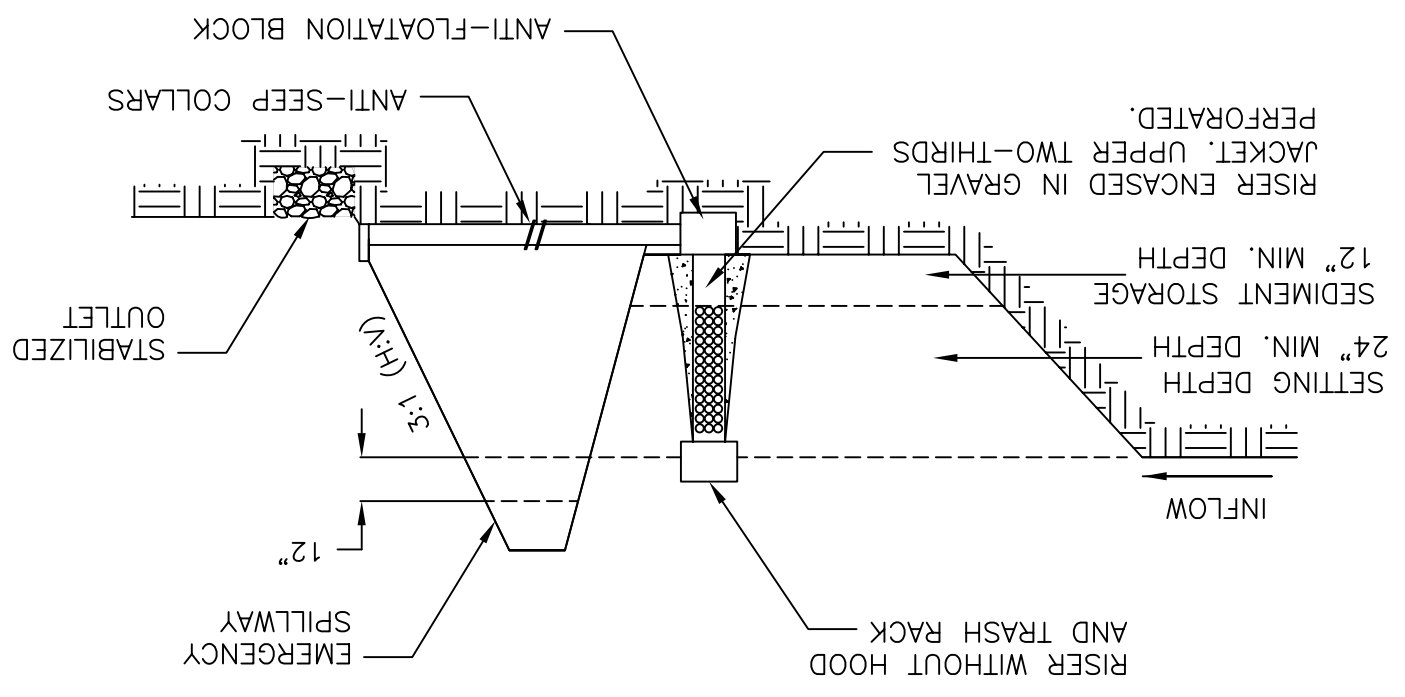

TOP VIEW

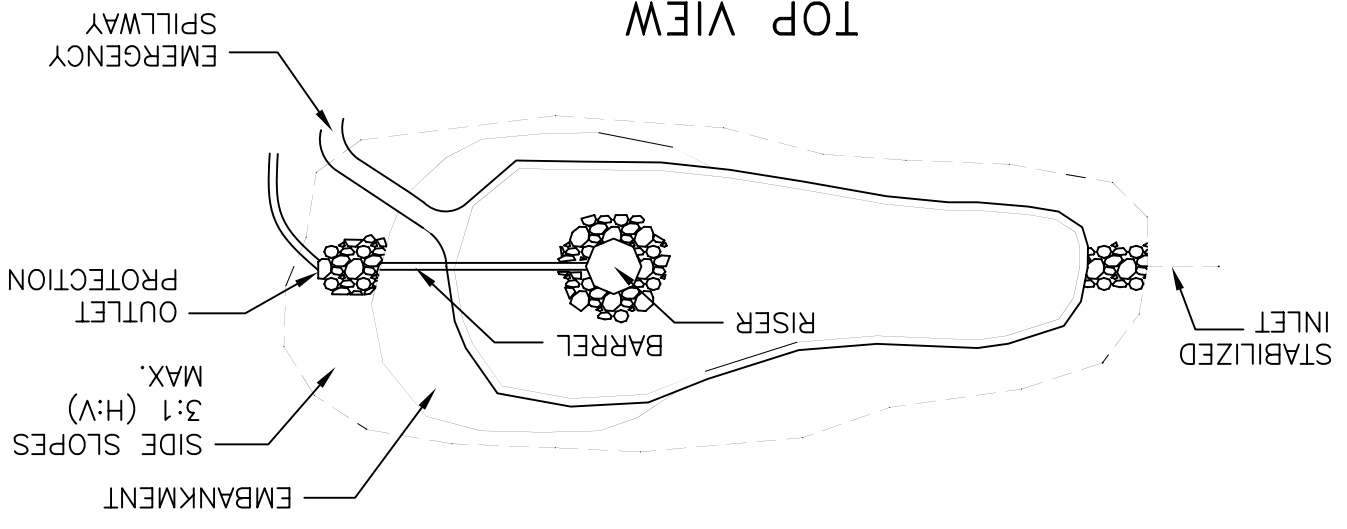

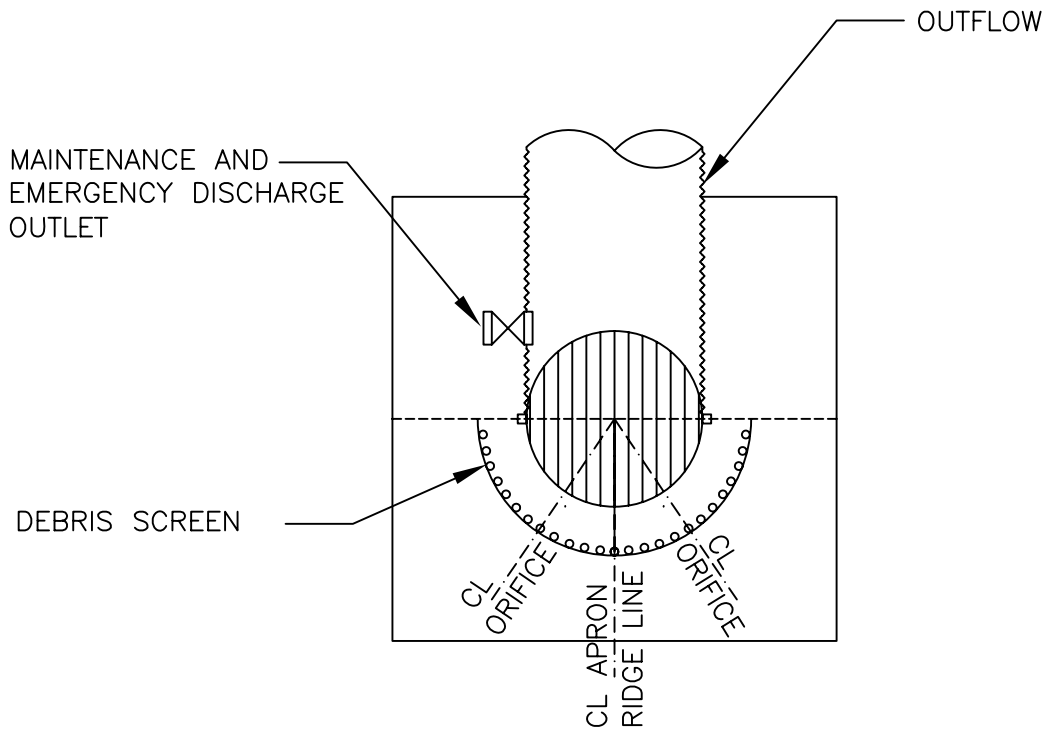

PLAN

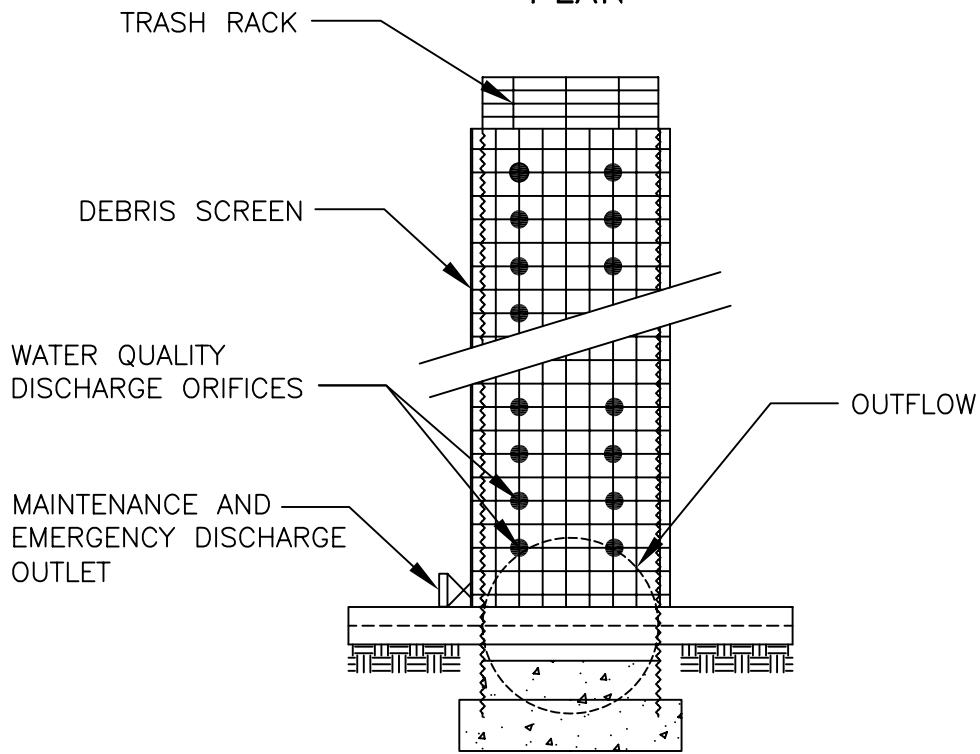

PROFILE

COUNTY OF YOLO PLANNING, RESOURCES AND PUBLIC WORKS DEPARTMENT		DATE: 03/16/06
MULTIPLE ORIFICE OUTLET RISER		SHEET # 3 OF 3
COUNTY ENGINEER R.C.E. C-56781	APPROVAL DATE	DRAWING #: 11-4.10C

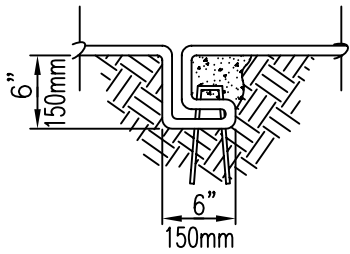

CHECK SLOT

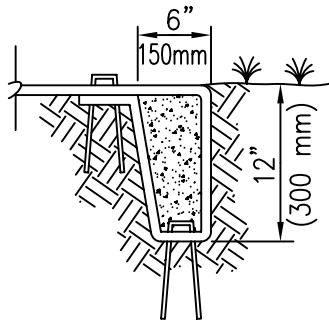

INITIAL CHANNEL ANCHOR TRENCH

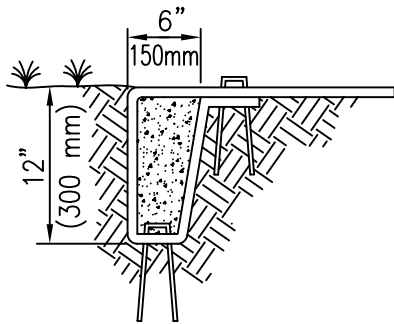

TERMINAL SLOPE AND CHANNEL ANCHOR TRENCH

STAKE AT 3-5 ft (1.0-1.5 m) INTERVALS

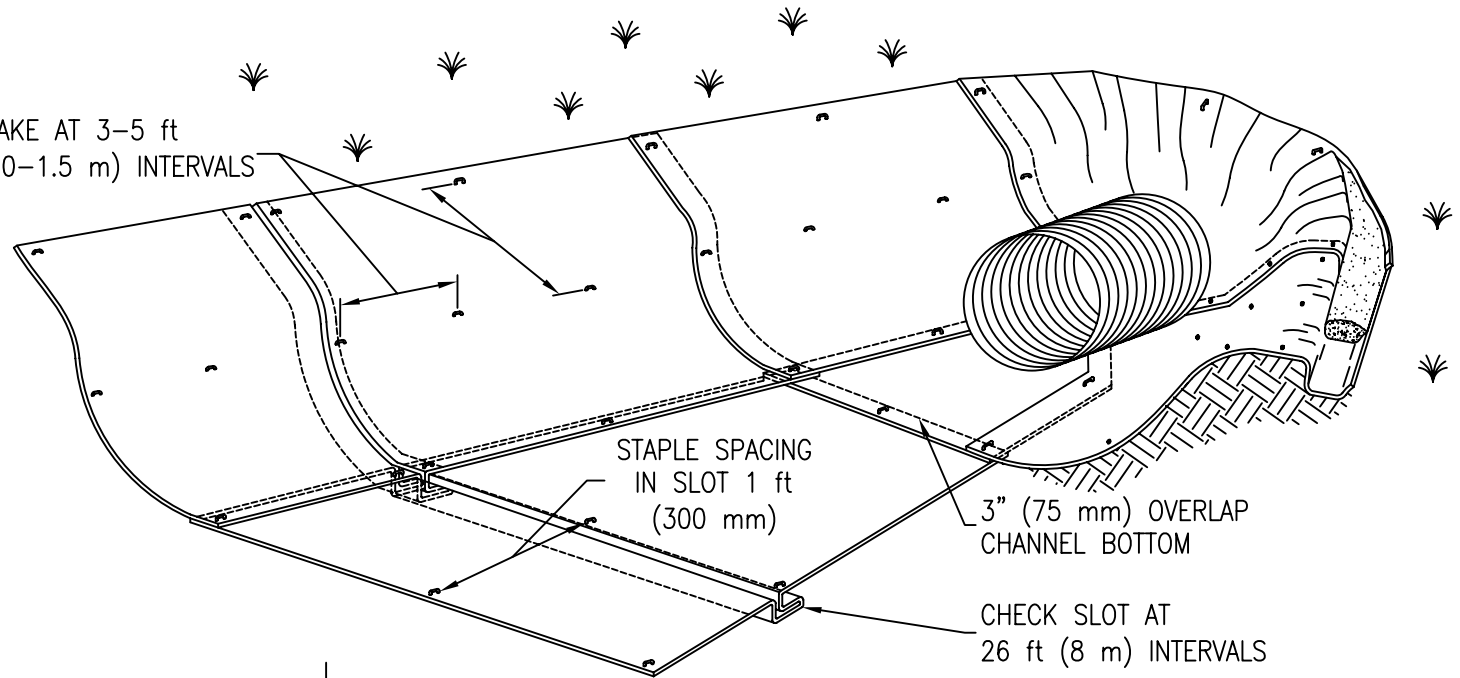

STAPLE SPACING IN SLOT 1 ft (300 mm)

3" (75 mm) OVERLAP CHANNEL BOTTOM

CHECK SLOT AT 26 ft (8 m) INTERVALS

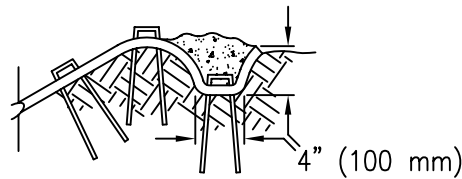

LONGITUDINAL ANCHOR TRENCH

TYPICAL CHANNEL SOIL STABILIZATION

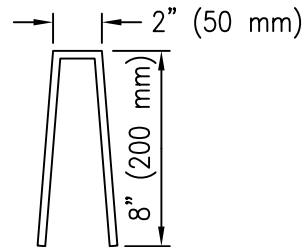

WIRE STAPLES

NOTE:

- 1.) CONSTRUCTION OF CHECK SLOTS, STAKING, STAPLING LAYOUT, AND MAT INSTALLATION ALL TO BE DONE PER MANUFACTURER'S SPECIFICATIONS.

COUNTY OF YOLO PLANNING, RESOURCES AND PUBLIC WORKS DEPARTMENT		DATE: 03/16/06
EROSION CONTROL BLANKETS/MATS CHANNEL INSTALLATION		SHEET # 1 OF 2
COUNTY ENGINEER R.C.E. C-56781		DRAWING #: 11-4.11A
APPROVAL DATE		

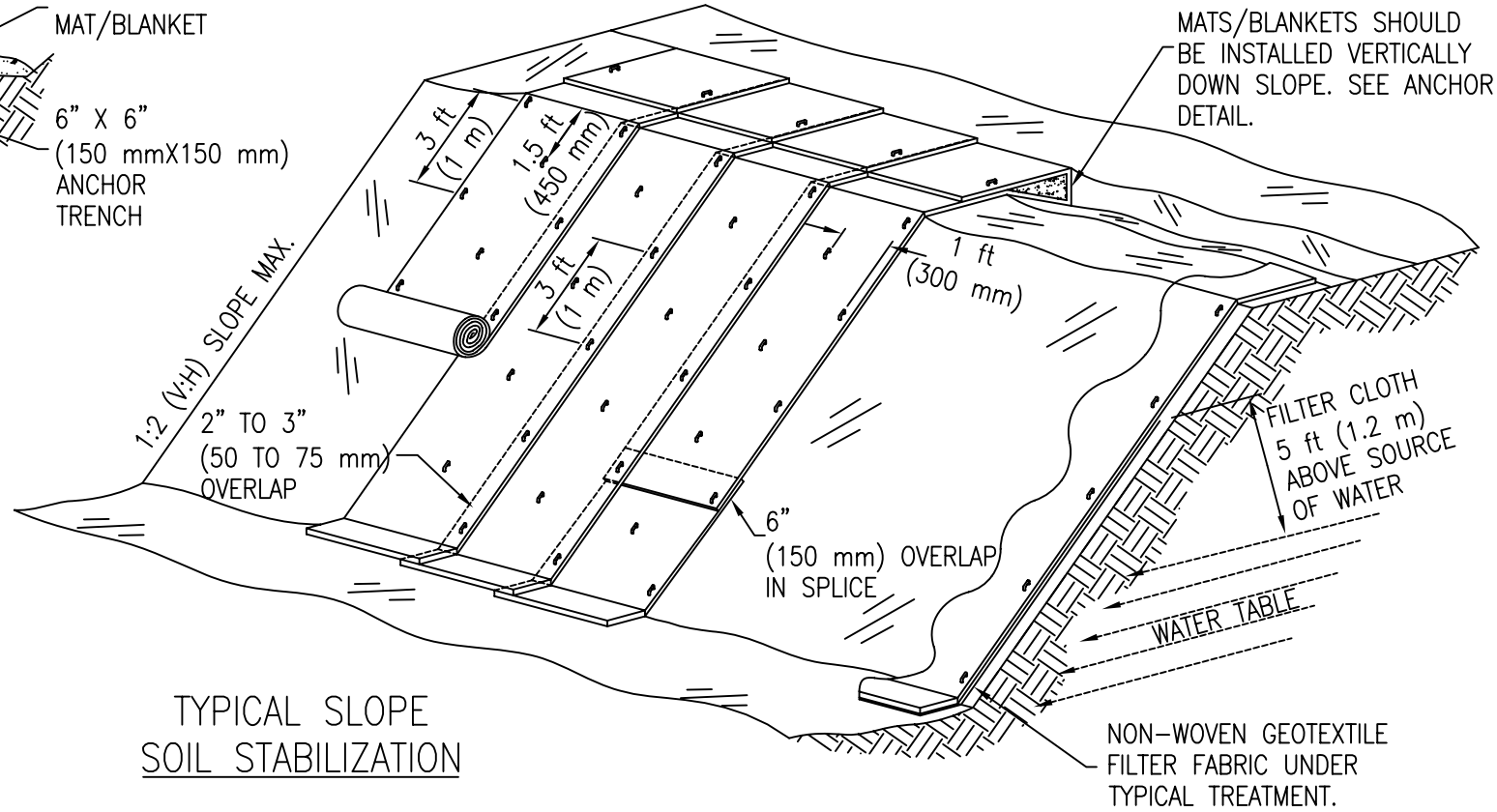
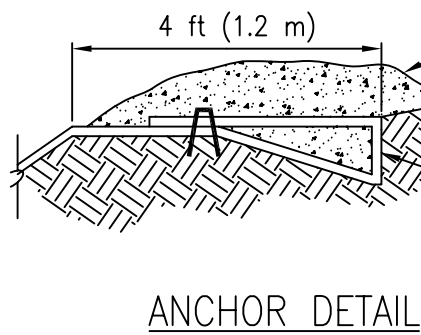

WET SLOPE LINING

NOTES:

1. SLOPE SURFACE SHALL BE FREE OF ROCKS, CLODS, STICKS AND GRASS. MATS/BLANKETS SHALL HAVE GOOD SOIL CONTACT.
2. LAY BLANKETS LOOSELY AND STAKE OR STAPLE TO MAINTAIN DIRECT CONTACT WITH THE SOIL. DO NOT STRETCH.
3. INSTALL PER MANUFACTURER'S RECOMMENDATIONS.

COUNTY OF YOLO PLANNING, RESOURCES AND PUBLIC WORKS DEPARTMENT		DATE: 03/16/06
EROSION CONTROL BLANKETS/MATS SLOPE INSTALLATION		SHEET # 2 OF 2
COUNTY ENGINEER R.C.E. C-56781	APPROVAL DATE	DRAWING #: 11-4.11B

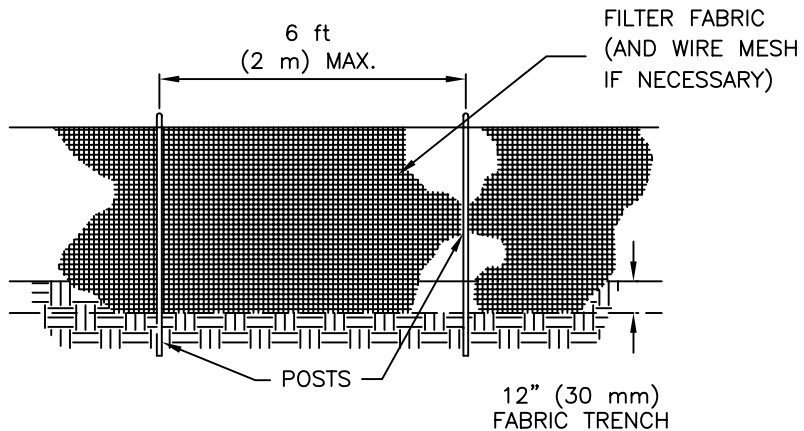

FRONT VIEW

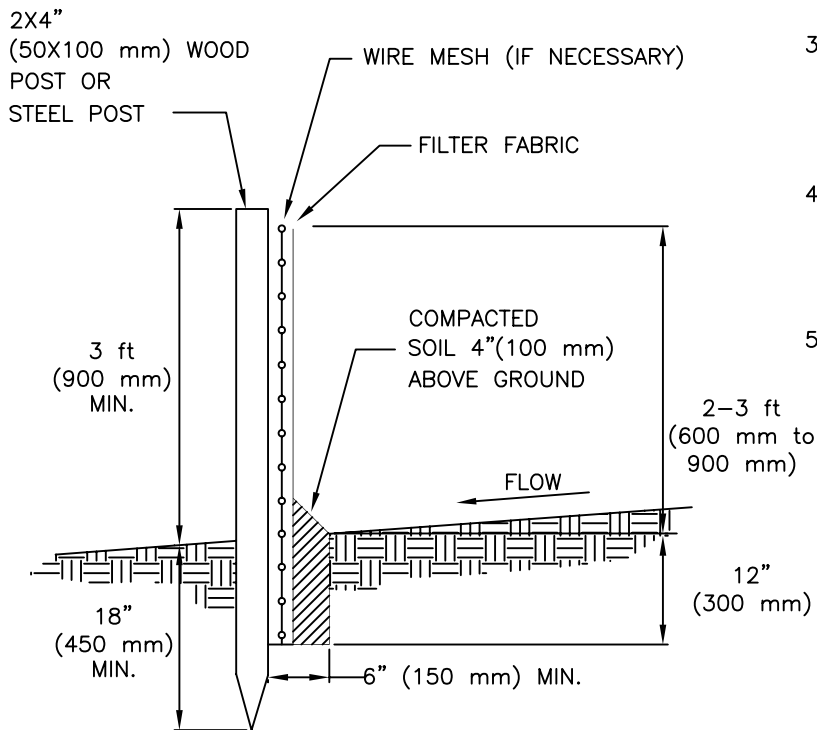

SECTION A-A

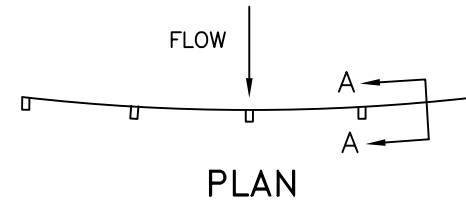

PLAN

NOTES:

1. SILT FENCE SHALL BE CONSTRUCTED LONG ENOUGH TO EXTEND ACROSS THE EXPECTED FLOW PATH AND AS APPROVED BY THE ADMINISTRATOR. THE MAXIMUM DISTANCE BETWEEN SILT FENCES SHALL BE 9 m X THE SLOPE EXPRESSED AS A RATIO.
2. FILTER FABRIC SHALL BE PROPYLENE, NYLON, POLYESTER OR ETHYLENE YARN WITH A MINIMUM TENSILE STRENGTH OF 50 LBS. PER LINEAR FOOT AT 20 PERCENT MAXIMUM ELONGATION AND CONTAINING ULTRAVIOLET INHIBITORS. FILTER FABRIC SHALL RETAIN A MINIMUM OF 85% OF THE SOIL, BY WEIGHT, BASED ON SIEVE ANALYSIS, BUT IS NOT FINER THAN AN EQUIVALENT OPENING SIZE OF 70. WHEN STANDARD STRENGTH FABRIC IS USED, A WIRE MESH SUPPORT SHALL BE SECURELY FASTENED TO THE UPSLOPE SIDE OF POSTS.
3. SUPPORT POSTS SHALL BE A MINIMUM 4.5 ft (1.4 m) LONG 2"x4" (50 X 100 mm) WOOD POSTS OR 'T' SECTION FENCE POSTS DRIVEN A MINIMUM OF 18" (450 mm) INTO THE GROUND. POSTS SHALL BE SPACED A MAXIMUM OF 6 ft (2 m) APART. FABRIC SHALL BE SECURELY FASTENED TO POSTS WITH 0.5" (13 mm) STAPLES OR 16 GAUGE WIRE TIES SPACED A MAXIMUM OF 6" (150 mm) APART.
4. A 12" (300 mm) FABRIC TRENCH SHALL BE EXCAVATED ALONG THE UPHILL SIDE OF SILT FENCE POSTS. THE BOTTOM EDGE OF THE FABRIC SHALL EXTEND TO AND ACROSS THE BOTTOM OF THE TRENCH. THE TRENCH SHALL BE BACKFILLED TO 4" (100 mm) ABOVE GROUND AND COMPACTED TO BURY AND SECURE THE BOTTOM OF THE FILTER FABRIC.
5. CONTRACTOR SHALL MAKE INSPECTIONS WEEKLY DURING THE WET SEASON, MONTHLY DURING THE DRY SEASON AND IMMEDIATELY BEFORE & AFTER EACH RAIN EVENT TO DETERMINE IF REPAIRS AND SEDIMENT REMOVAL IS REQUIRED. SEDIMENT SHALL BE REMOVED BEFORE IT HAS REACHES 6" (150 mm) IN DEPTH AND DISPOSED OF PROPERLY.

COUNTY OF YOLO PLANNING, RESOURCES AND PUBLIC WORKS DEPARTMENT		DATE: 03/16/06
SILT FENCE		SHEET # 1 OF 3
COUNTY ENGINEER R.C.E. C-56781	APPROVAL DATE	DRAWING #: 11-4.12A

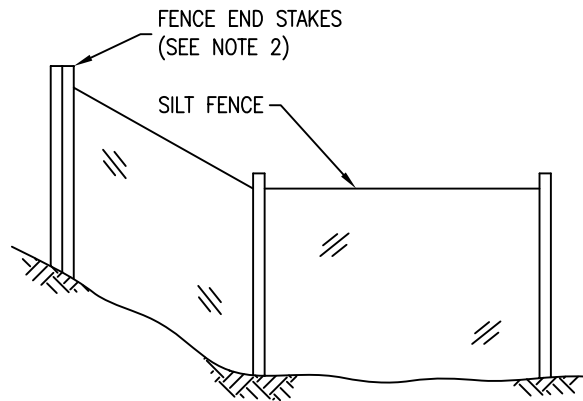

FENCE END DETAIL

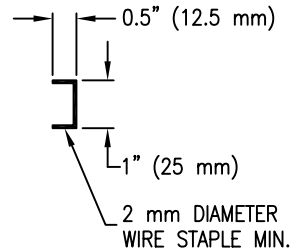

STAPLE DETAIL

NOTES:

1. CONSTRUCT THE LENGTH OF EACH REACH SO THAT THE CHANGE IN BASE ELEVATION ALONG THE REACH DOES NOT EXCEED 1/3 OF THE HEIGHT OF THE LINEAR BARRIER. IN NO CASE SHALL THE REACH LENGTH EXCEED 500 ft (150 m).
2. THE LAST 8 ft (2.5 m) OF FENCE SHALL BE TURNED UP SLOPE.
3. STAKE DIMENSIONS ARE NOMINAL.
4. DIMENSIONS MAY VARY TO FIT FIELD CONDITION.
5. STAKES SHALL BE SPACED AT 8 ft (2.5 m) MAXIMUM AND SHALL BE POSITIONED ON THE DOWNSTREAM SIDE OF THE FENCE.
6. OVERLAP STAKES, AND FOLD FENCE FABRIC TO AROUND EACH STAKE ONE FULL TURN.
7. STAKES SHALL BE DRIVEN TIGHTLY TOGETHER TO PREVENT POTENTIAL FLOW THROUGH OF SEDIMENT AT THE JOINT.
8. FOR END STAKE CONDITION FOLD FENCE FABRIC AROUND TWO (2) STAKES ONE (1) FULL TURN AND SECURE WITH (4) STAPLES.
9. MINIMUM (4) STAPLES PER STAKE.
10. CROSS BARRIERS SHALL BE A MINIMUM OF 1/3 AND A MAXIMUM OF 1/2 THE HEIGHT OF THE LINEAR BARRIER.

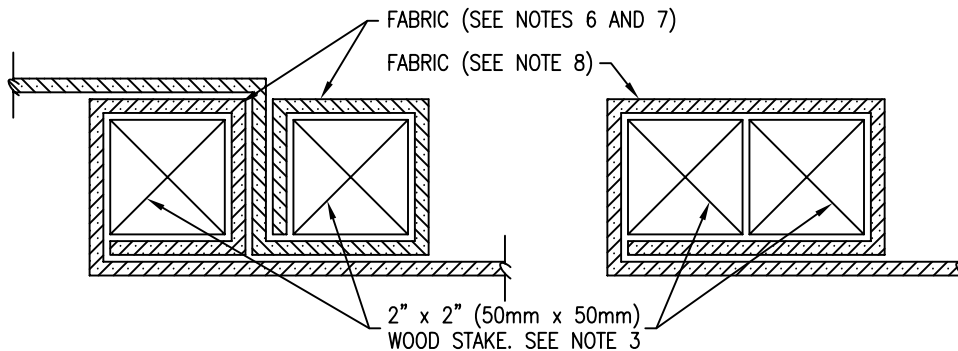

JOINT DETAIL

END STAKE DETAIL

COUNTY OF YOLO PLANNING, RESOURCES AND PUBLIC WORKS DEPARTMENT	DATE: 03/16/06
SILT FENCE DETAIL	SHEET # 2 OF 3
COUNTY ENGINEER R.C.E. C-56781	APPROVAL DATE 11-4.12B

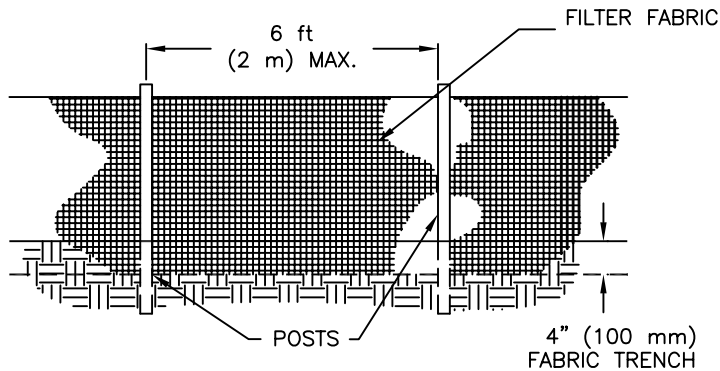

FRONT VIEW

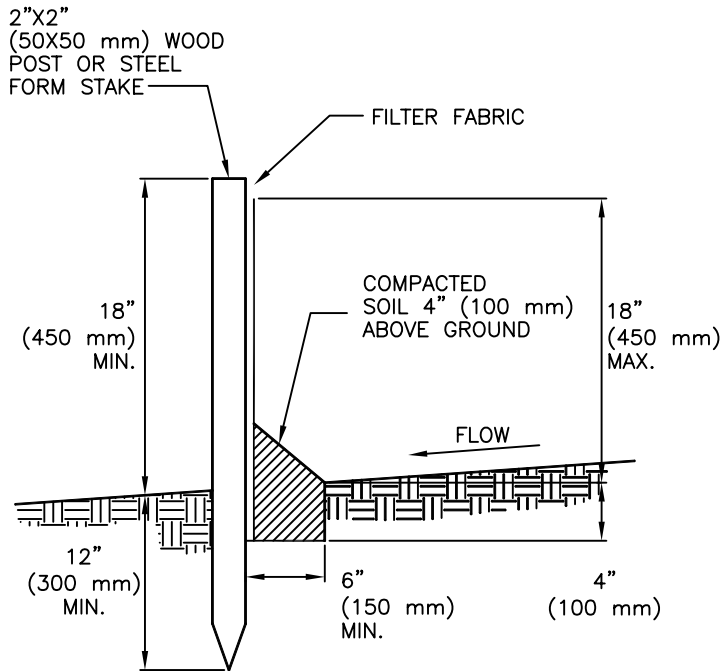

SECTION A-A

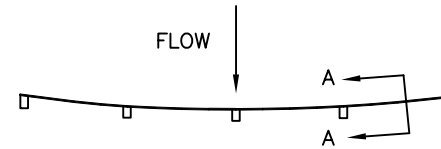

PLAN

NOTES:

1. **FILTER BARRIER** SHALL BE CONSTRUCTED LONG ENOUGH TO EXTEND ACROSS THE EXPECTED FLOW PATH AND AS APPROVED BY THE ADMINISTRATOR. THE MAXIMUM DISTANCE BETWEEN FILTER BARRIERS SHALL BE 4.5 m X THE SLOPE EXPRESSED AS A RATIO.
2. FILTER FABRIC SHALL BE PROPYLENE, NYLON, POLYESTER OR ETHYLENE YARN WITH A MINIMUM TENSILE STRENGTH OF 50 LBS. PER LINEAR FOOT AT 20 PERCENT MAXIMUM ELONGATION AND CONTAINING ULTRAVIOLET INHIBITORS. FILTER FABRIC SHALL **RETAIN** A MINIMUM OF 85% OF THE SOIL, BY WEIGHT, BASED ON SIEVE ANALYSIS, **BUT IS NOT FINER** THAN AN EQUIVALENT OPENING SIZE OF 70.
3. SUPPORT POSTS SHALL BE A MINIMUM 30" (750 mm) LONG 2"x2" (50X50 mm) WOOD POSTS OR STEEL FORM STAKES DRIVEN A MINIMUM OF 12" (300 mm) INTO THE GROUND. POSTS SHALL BE SPACED A MAXIMUM OF 6 ft (2 m) APART. FABRIC SHALL BE SECURELY FASTENED TO POSTS WITH 0.5" (13 mm) STAPLES OR 16 GAUGE WIRE TIES SPACED A MAXIMUM OF 6" (150 mm) APART.
4. A 4" (100 mm) FABRIC TRENCH SHALL BE EXCAVATED ALONG THE UPHILL SIDE OF FILTER BARRIER POSTS. THE BOTTOM EDGE OF THE FABRIC SHALL EXTEND TO AND ACROSS THE BOTTOM OF THE TRENCH. THE TRENCH SHALL BE BACKFILLED TO 4" (100 mm) ABOVE GROUND AND COMPACTED TO BURY AND SECURE THE BOTTOM OF THE FILTER FABRIC.
5. CONTRACTOR SHALL MAKE INSPECTIONS WEEKLY DURING THE WET SEASON, BEFORE & IMMEDIATELY AFTER EACH RAINFALL EVENT, AND MONTHLY DURING THE DRY SEASON TO DETERMINE IF REPAIRS & SEDIMENT REMOVAL ARE REQUIRED. SEDIMENT SHALL BE REMOVED BEFORE IT HAS REACHED ONE THIRD (1/3) THE HEIGHT OF THE FILTER FABRIC AND DISPOSED OF PROPERLY.

COUNTY OF YOLO PLANNING, RESOURCES AND PUBLIC WORKS DEPARTMENT		DATE: 03/16/06
FILTER BARRIERS		SHEET # 3 OF 3
COUNTY ENGINEER R.C.E. C-56781	APPROVAL DATE	DRAWING #: 11-4.12C

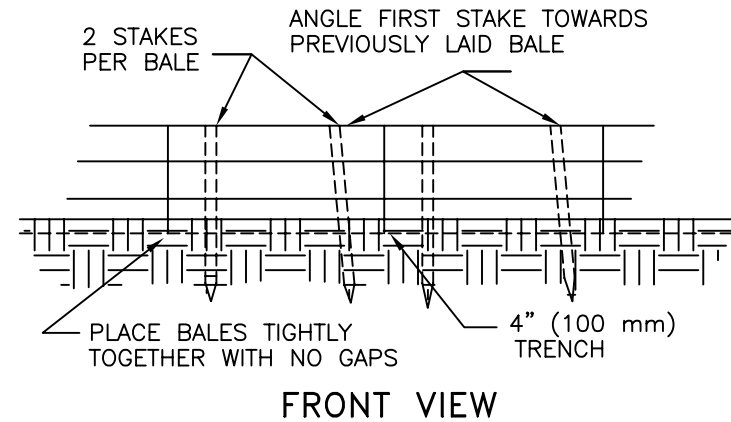
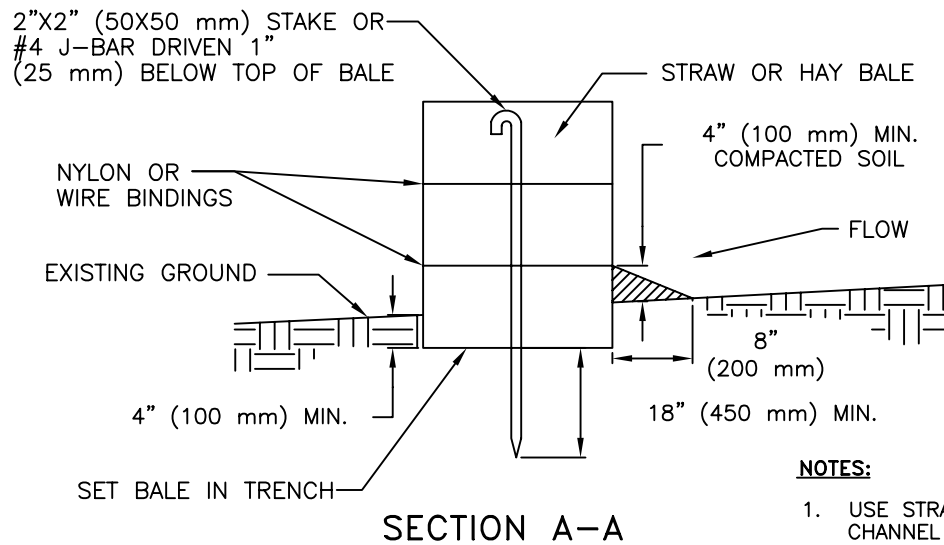

NOTES:

1. USE STRAW BALE BARRIERS TO DECREASE THE VELOCITY OF LOW-TO-MODERATE LEVEL CHANNEL FLOWS. DO NOT PLACE ACROSS STREAMS, DITCHERS, OR WHERE FLOWS ARE CONCENTRATED. THE DRAINAGE AREA MUST BE RESTRICTED AND THE BARRIER LOCATED SO THAT THE WATER DEPTH DOES NOT EXCEED 1 ft (305 mm) AT ANY POINT.
2. PLACE BALES IN 4" (100 mm) DEEP TRENCH ALONG THE CONTOUR OF THE SLOPE IN THE SHAPE OF AN ARC WITH THE ENDS UPHILL OF THE ARC'S CENTER. BALES SHALL BE PLACED SO THAT BINDINGS ARE HORIZONTAL. MAXIMUM SPACING BETWEEN ROWS SHALL BE 30 ft (9 m) x THE SLOPE STEEPNESS EXPRESSED AS A RATIO.
3. BALES SHALL BE ANCHORED BY TWO 2"x2" (50x50 mm) STAKES OR #4 J-BAR DRIVEN THROUGH THE BALE AND INTO THE GROUND A MINIMUM DEPTH OF 18" (450 mm). STAKES OR J-BARS SHALL BE DRIVEN 1" (25 mm) OR MORE BELOW THE TOP OF THE BALE. THE FIRST STAKE OR J-BAR IN EACH BALE SHALL BE DRIVEN AT AN ANGLE TOWARDS THE PREVIOUSLY LAID BALE TO FORCE THE BALES TIGHTLY TOGETHER.
4. AFTER BALES ARE STAKED IN PLACE, EXCAVATED SOIL SHALL BE BACKFILLED AGAINST THE UPHILL SIDE TO A MINIMUM HEIGHT OF 4" (100 mm).
5. CONTRACTOR SHALL INSPECT BALES WEEKLY, BEFORE & AFTER EACH RAIN EVENT. REPAIRS SHALL BE MADE AS NECESSARY AND SEDIMENT SHALL BE REMOVED WHEN IT HAS ACCUMULATED TO A DEPTH OF 6" (150 mm). SEDIMENT SHALL BE DISPOSED OF PROPERLY. BALES SHALL BE REPLACED WHEN THEY HAVE BEEN DAMAGED, COLLAPSED OR DECOMPOSED.
6. USE STRAW BALE BARRIERS TO PROVIDE EROSION PROTECTION AT OVERFLOW POINTS. STRAW BALE BARRIERS ARE TO PROVIDE BACK-UP PROTECTION, NOT AS **FIRST LINE OF DEFENSE**.

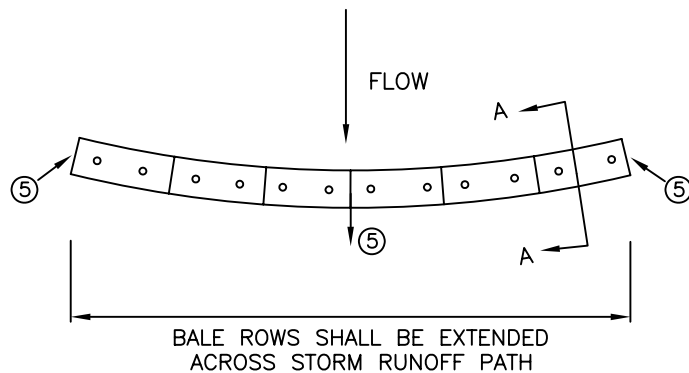

STRAW BALE ALIGNMENT

COUNTY OF YOLO PLANNING, RESOURCES AND PUBLIC WORKS DEPARTMENT		DATE: 03/16/06
STRAW BALE BARRIER		SHEET # 1 OF 1
COUNTY ENGINEER R.C.E. C-56781	APPROVAL DATE	DRAWING #: 11-4.13

PLACEMENT AT TYPE B AND E DROP INLETS

PLACEMENT AT TYPE A, C, D, & F DROP INLETS AND PARKING LOTS

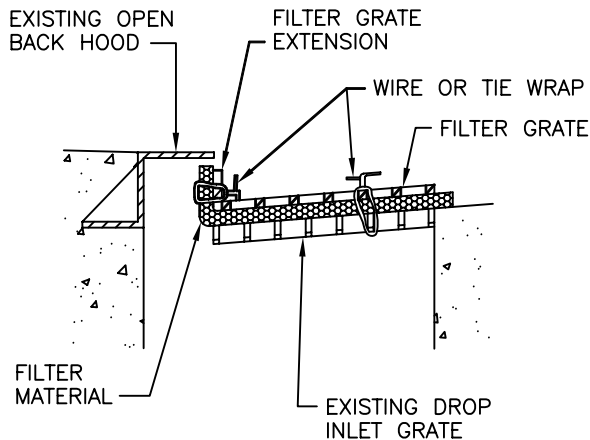
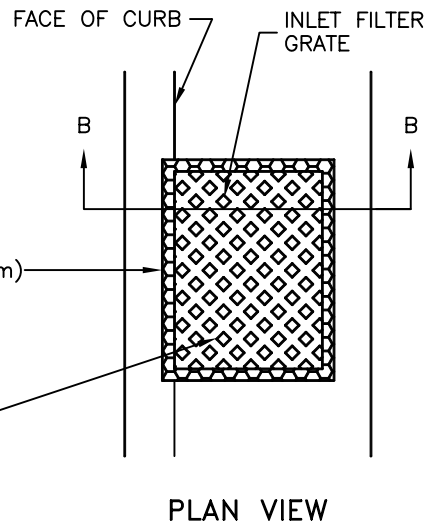
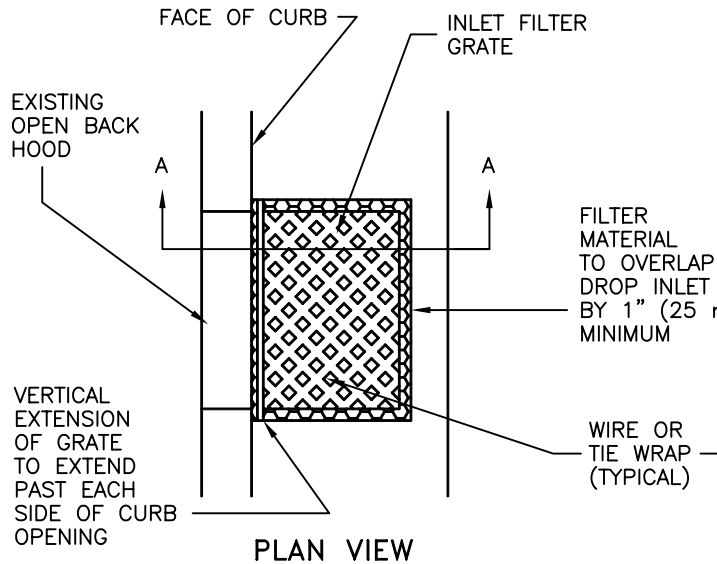

SECTION A-A

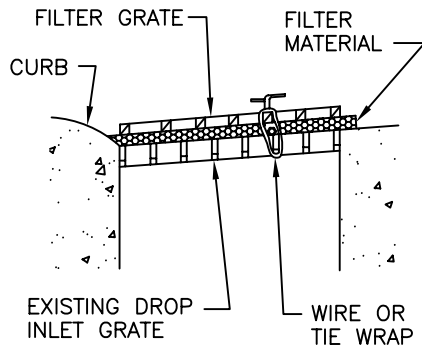

SECTION B-B

NOTES:

1. THE MAXIMUM DRAINAGE AREA PER FILTER SHALL BE NO MORE THAN 2 ACRES (0.8 HECTARES).
2. THE FILTER PAD SHALL BE 1" (25 mm) THICK CLEANABLE POLYESTER FIBER AND ACRYLIC LATEX RESIN OR APPROVED EQUAL. THE FILTER PAD SHALL OVERLAP DROP INLET ON ALL SIDES BY A MINIMUM OF 1" (25 mm).
3. THE FILTER GRATE SHALL BE MADE OF EXPANDED METAL OR REBAR AND BE OF SUFFICIENT STRENGTH TO PREVENT BENDING WHEN DRIVEN OVER. GRATE MATERIAL SHALL NOT EXCEED 0.5" (13 mm) THICK. THE GRATE SHALL HAVE A MINIMUM 60% OPEN AREA. GRATES USED AT TYPE B AND E INLETS SHALL HAVE A VERTICAL EXTENSION TO COVER THE CURB OPENING. THE FILTER GRATE SHALL BE THE SAME SIZE AS THE DROP INLET GRATE.
4. THE FILTER PAD AND GRATE SHALL BE SECURELY ATTACHED TO THE DROP INLET BY WIRE OR TIE-WRAPPS.
5. INLET FILTERS SHALL BE INSPECTED WEEKLY AND BEFORE & AFTER EACH RAINFALL EVENT. REPAIRS SHALL BE MADE AS NEEDED. SEDIMENT & DEBRIS SHALL BE REMOVED AND DISPOSED OF PROPERLY.

COUNTY OF YOLO PLANNING, RESOURCES AND PUBLIC WORKS DEPARTMENT		DATE: 03/16/06
STORM DRAIN INLET FILTER		SHEET # 1 OF 3
COUNTY ENGINEER R.C.E. C-56781	APPROVAL DATE	DRAWING #: 11-4.14A

PLACEMENT AT TYPE B AND E DROP INLETS

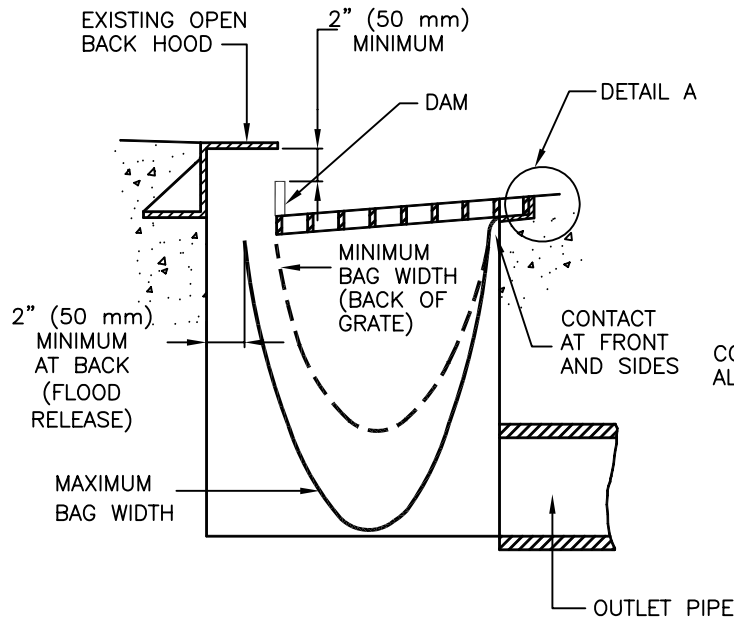

PLACEMENT AT TYPE A, C, D, & F DROP INLETS AND PARKING LOTS

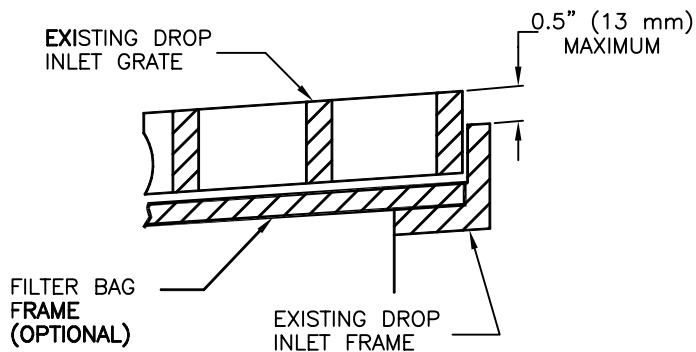
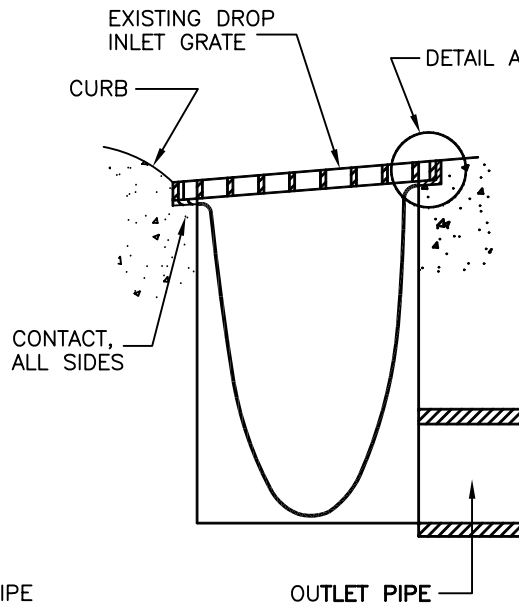

DETAIL A

NOTES:

1. THE MAXIMUM DRAINAGE AREA PER FILTER SHALL BE NO MORE THAN 2 ACRES (0.8 HECTARES).
2. THE FILTER BAG SHALL BE MANUFACTURED FROM UV RESISTANT POLYPROPYLENE, NYLON, POLYESTER, OR ETHYLENE FABRIC WITH A MINIMUM TENSILE STRENGTH OF 50 LBS PER LINEAL FOOT, AN EQUIVALENT OPENING SIZE NOT GREATER THAN A 20 SIEVE AND WITH A MINIMUM FLOW RATE OF 40 GALLONS / MINUTE / SQ FT.
3. THE FILTER BAG MAY BE SUSPENDED FROM OR HELD IN PLACE BY THE EXISTING INLET GRATE (OR OTHER APPROVED METHOD), PROVIDING NO MODIFICATION OR DAMAGE SHALL BE DONE TO THE INLET GRATE OR FRAME. THE INLET GRATE **SHALL NOT BE CAUSED TO REST MORE THAN 0.5" (13 mm) ABOVE THE INLET FRAME** (SEE DETAIL A).
4. THE FILTER BAG MAY EXTEND TO THE BOTTOM OF THE INLET BOX PROVIDED THE OUTLET PIPE IS UNOBSTRUCTED.
5. FLOWS SHALL NOT BE ALLOWED TO BYPASS THE BAG. THE BAG OR ITS FRAME SHALL CATCH FLOWS AT ALL SIDES OF THE INLET, EXCEPT AS SHOWN FOR FLOOD RELEASE.
6. INLET FILTER BAGS SHALL BE INSPECTED WEEKLY AND AFTER EACH RAINFALL DURING THE WET SEASON AND MONTHLY DURING THE DRY SEASON. SEDIMENT AND DEBRIS SHALL BE REMOVED BEFORE ACCUMULATIONS HAVE REACHED ONE THIRD THE DEPTH OF THE BAG. BAGS SHALL BE REPAIRED OR REPLACED AS SOON AS DAMAGE OCCURS.
7. AN APPROVED ALTERNATIVE ARE THE "GRATE-MATES". THESE ARE PROVIDED WITH SLOTS THAT POLES CAN BE INSERTED FOR LIFTING OUT THE FILTER BAGS.

COUNTY OF YOLO PLANNING, RESOURCES AND PUBLIC WORKS DEPARTMENT	DATE: 03/16/06
STORM DRAIN INLET FILTER BAG	SHEET # 2 OF 3
COUNTY ENGINEER R.C.E. C-56781	DRAWING #: 11-4.14B
APPROVAL DATE _____	

GRAVEL BAG(S) OR OTHER ACCEPTED
SEDIMENT CONTROL BMP. PLACE BAGS
TIGHT AGAINST FACE OF CURB.

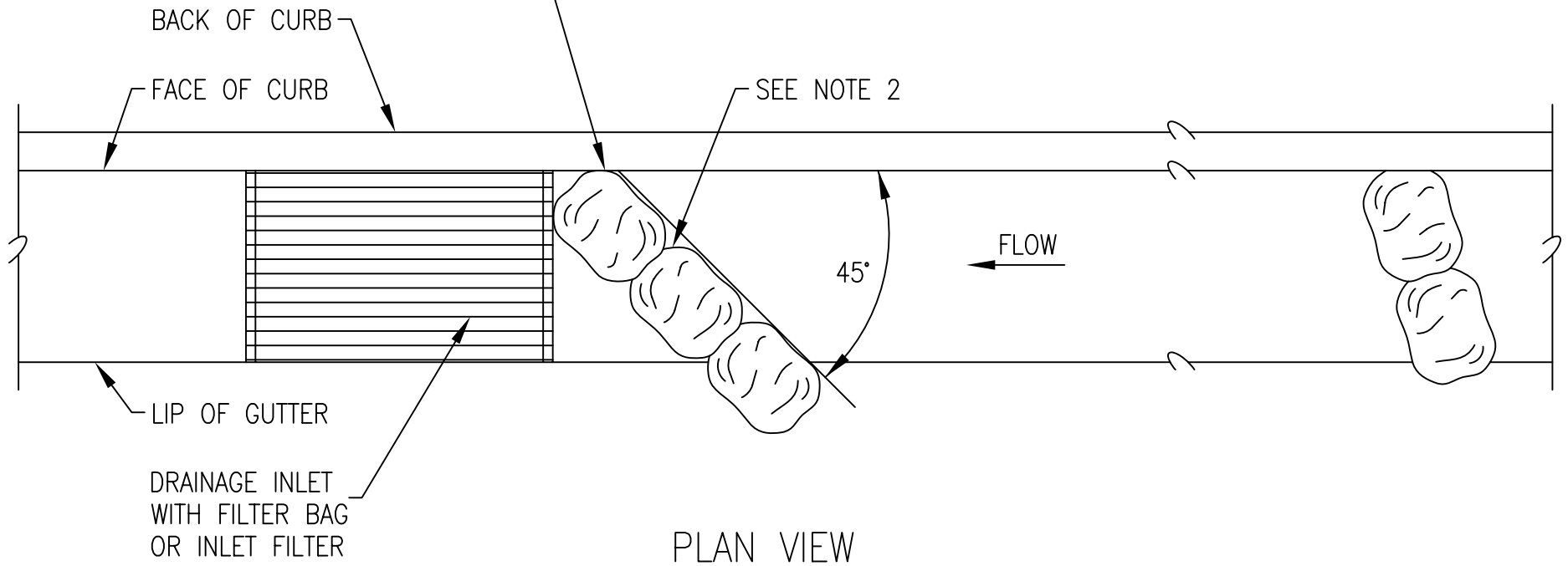

NOTES:

1. SEDIMENT TRAPPED UPSTREAM OF SEDIMENT CONTROL BMP SHALL BE REMOVED WEEKLY AND PRIOR TO & AFTER A RAINFALL EVENT.
2. PLACE BMP'S TIGHTLY TOGETHER AT JOINTS TO PREVENT OR MINIMIZE SEEPAGE AT JOINTS.
3. REPAIR WASHOUTS & OTHER DAMAGE AS NEEDED.
4. REMOVE BARRIER WHEN NO LONGER NEEDED.

COUNTY OF YOLO PLANNING, RESOURCES AND PUBLIC WORKS DEPARTMENT	DATE: 03/16/06
INLET SEDIMENT CONTROL	SHEET # 3 OF 3
COUNTY ENGINEER R.C.E. C-56781	APPROVAL DATE 11-4.14C

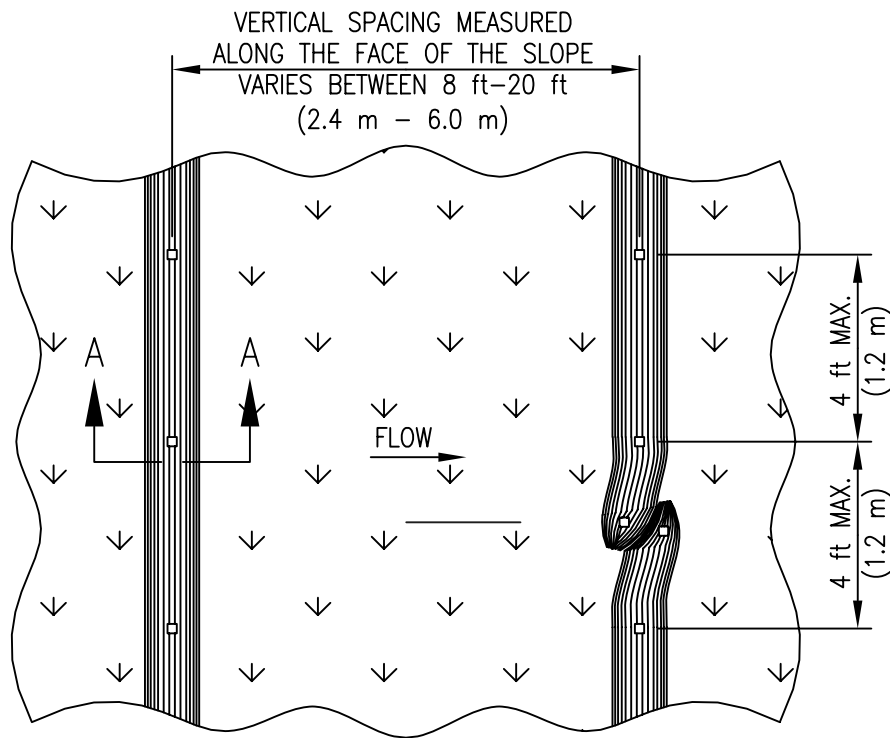

TYPICAL FIBER ROLL INSTALLATION

NOTES:

1. INSTALL FIBER ROLLS IN A ROW ALONG A LEVEL CONTOUR.
2. AT ENDS OF A ROW TURN THE LAST TWO FEET UP SLOPE SLIGHTLY.
3. FIBER ROLLS SHALL BE OVERLAPPED TIGHTLY AND STAKED AT THE JOINTS.
4. FIBER ROLLS WORK BEST IN CONJUNCTION WITH GOOD EROSION CONTROL BMPs.
5. INSPECT FIBER ROLLS WEEKLY AND BEFORE & AFTER A RAINFALL EVENT. REPAIR & REPLACE AS NEEDED.

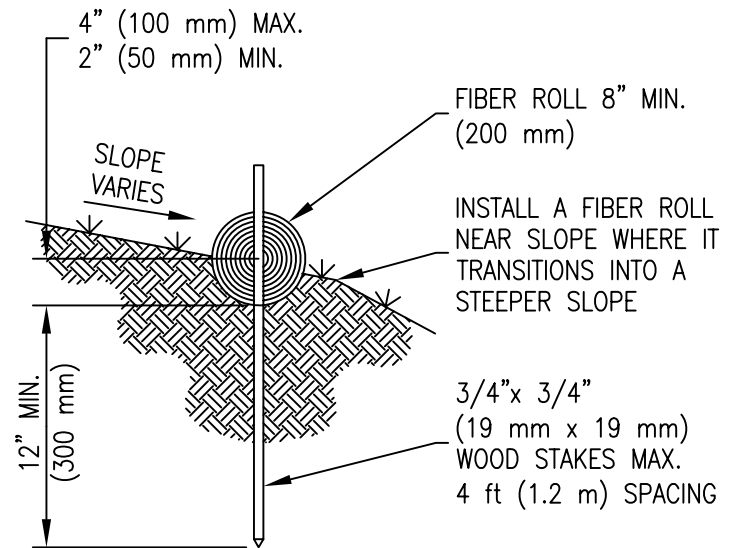

SECTION A - A

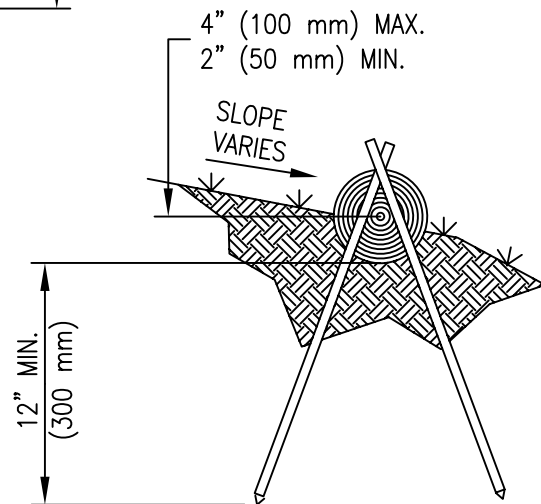

ALTERNATE STAKING DETAIL

COUNTY OF YOLO PLANNING, RESOURCES AND PUBLIC WORKS DEPARTMENT		DATE: 03/16/06
FIBER ROLLS		SHEET # 1 OF 1
COUNTY ENGINEER R.C.E. C-56781	APPROVAL DATE	DRAWING #: 11-4.16

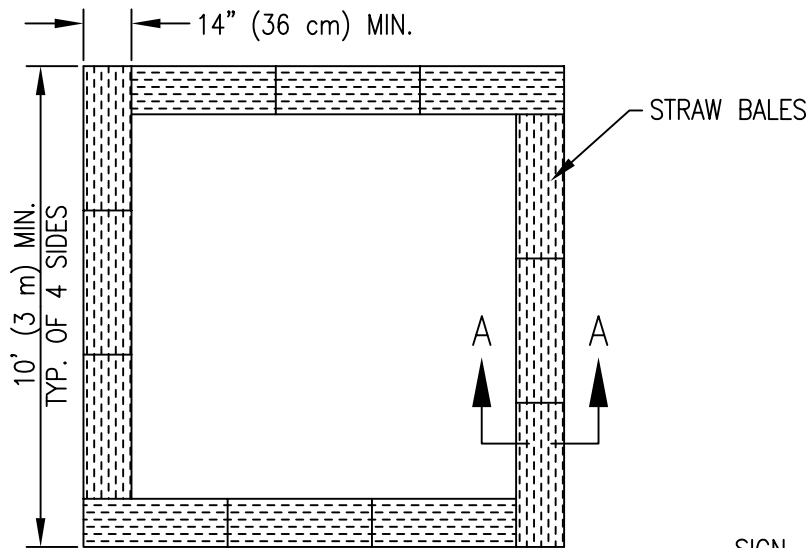

BALE CONFIGURATION

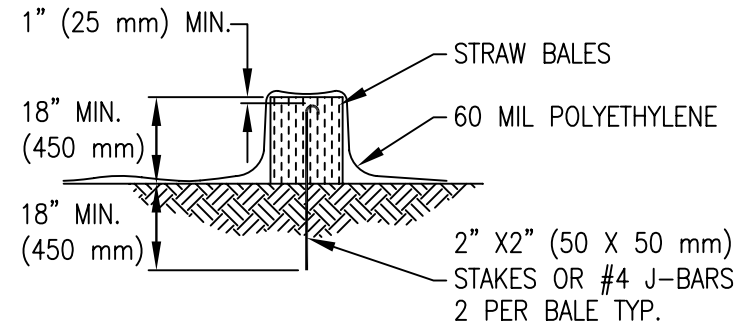

SECTION A - A

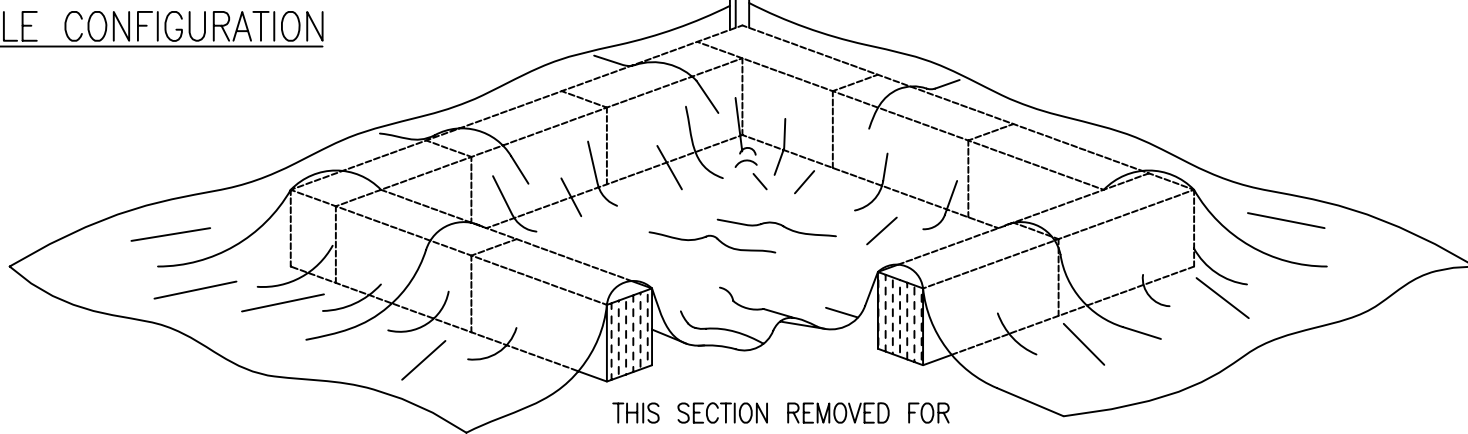
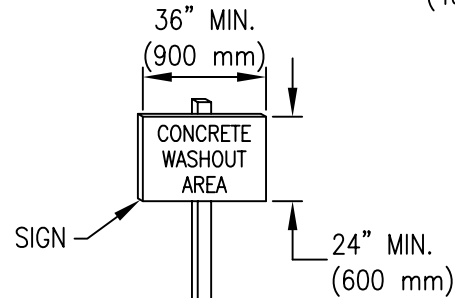

THIS SECTION REMOVED FOR GRAPHICAL REPRESENTATION ONLY. STRAW BALE PERIMETER SHALL BE CONTINUOUS.

NOTES:

1. FACE SIGN TOWARD NEAREST STREET OR ACCESS POINT.
2. CONCRETE WASHOUT SHALL BE LOCATED BEHIND THE CURB AND 50 ft (15 m) MINIMUM FROM DRAINAGE INLETS OR WATERCOURSES
3. CONCRETE WASH OUT SHALL BE INSPECTED & MAINTAINED TO PREVENT LEAKS OR OVERFLOWS.
4. WASHOUT MUST BE CLEANED, OR NEW ONE BUILT ONCE IT REACHES 75% CAPACITY.

COUNTY OF YOLO PLANNING, RESOURCES AND PUBLIC WORKS DEPARTMENT	DATE: 03/16/06
CONCRETE WASHOUT	SHEET # 1 OF 1
COUNTY ENGINEER R.C.E. C-56781	APPROVAL DATE 11-4.17

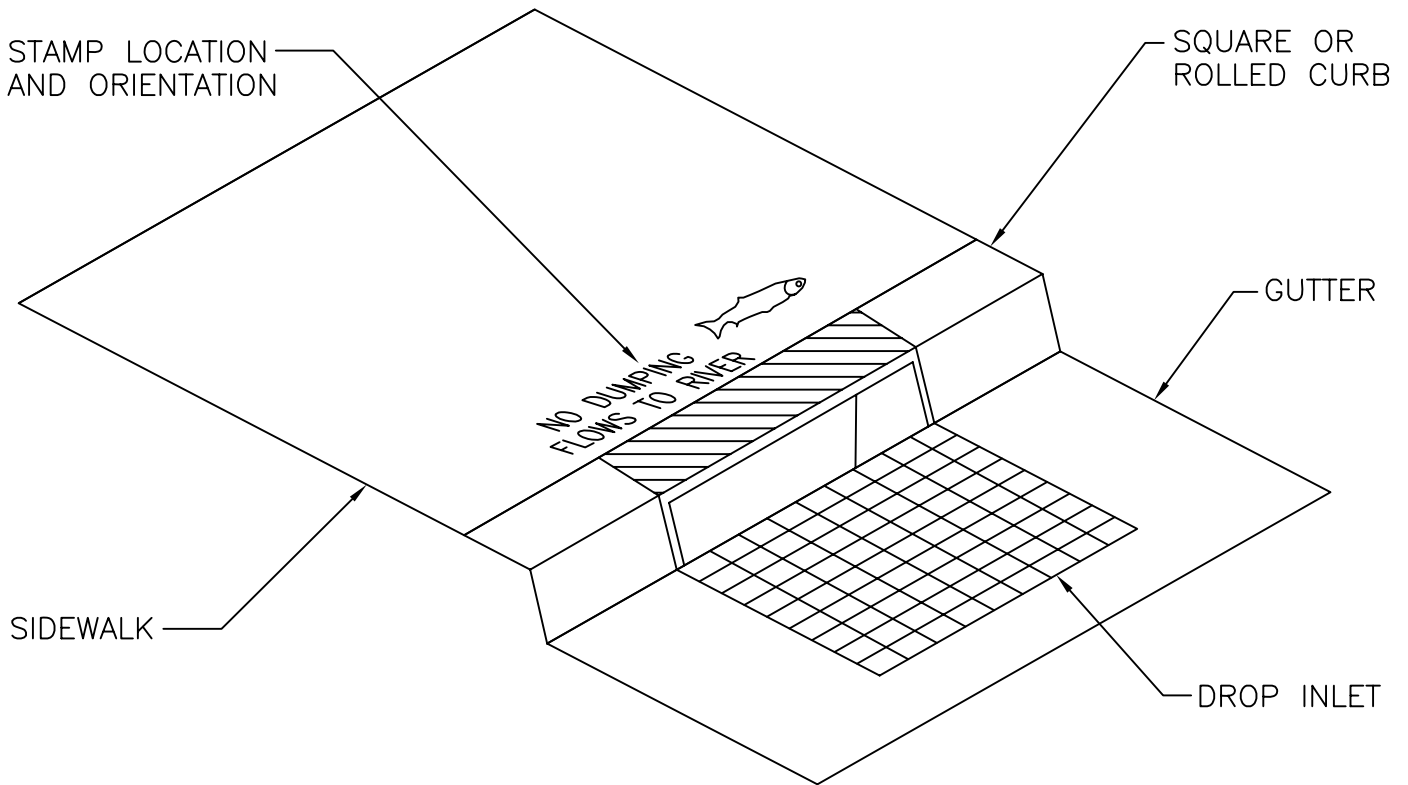

NOTES:

1. MESSAGE AND SYMBOL SHALL BE AS SHOWN ON SHEET 11-19B OR AS APPROVED BY THE ADMINISTRATOR.
2. LETTERS SHALL BE 1.5" (38 mm) IN HEIGHT. THE MESSAGE SHALL BE CENTERED ON THE BACK OF THE INLET.
3. CONCRETE SHALL BE STAMPED IN SUCH A WAY AS TO PROVIDE FOR A CLEAR AND LEGIBLE IMAGE. (APPROXIMATE DEPTH OF .25" OR 6 mm)
4. ALL STAMPS SHALL BE APPROVED BY THE ADMINISTRATOR BEFORE BEING USED.
5. STAMP MAY BE PERMANENTLY CAST INTO CAST IRON FRAME OR PRE-CAST CONCRETE PORTIONS OF INLET.
6. WERE RETROFITTING IS REQUIRED AN EPOXIED PLACARD BARING THE MESSAGE AND SYMBOL APPROVED BY THE ADMINISTRATOR SHALL BE PERMANENTLY AFFIXED ON THE BACK OF THE INLET.

COUNTY OF YOLO PLANNING, RESOURCES AND PUBLIC WORKS DEPARTMENT	DATE: 03/16/06
STORMWATER QUALITY DROP INLET CONCRETE STAMPS	SHEET # 1 OF 2
COUNTY ENGINEER R.C.E. C-56781	APPROVAL DATE 11-5.2.5A

STAMP MESSAGES AND SYMBOLS

DIMENSIONS MAY VARY AMONG THE STAMP DESIGNS SHOWN BELOW, BUT SHALL NOT EXCEED THE MAXIMUM DIMENSIONS.

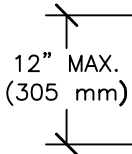
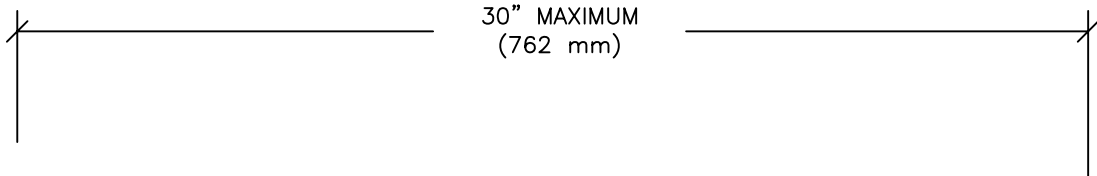

**NO DUMPING!
FLOWS TO CREEK**

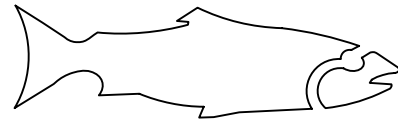

NO DUMPING  I LIVE
DOWNSTREAM

NO DUMPING!
FLOWS TO RIVER

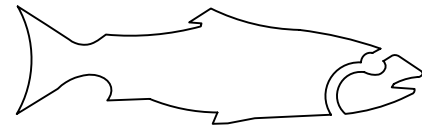

COUNTY OF YOLO PLANNING, RESOURCES AND PUBLIC WORKS DEPARTMENT		DATE: 03/16/06
DROP INLET STAMP MESSAGES and SYMBOLS		SHEET # 2 OF 2
COUNTY ENGINEER R.C.E. C-56781	APPROVAL DATE	DRAWING #: 11-5.2.5B