

# County of Yolo Improvement Standards

Department of Planning and Public Works  
292 West Beamer Street  
Woodland, CA 95695

August 5, 2008

**ADDENDA AND UPDATES**

<b>DATE</b>	<b>LOCATION AND DESCRIPTION OF REVISED SHEETS</b>
06/01/2009	Unistrut tubing used to extend 30" below ground level. Per this revision it is embedded 6" to 8" into anchor. Dwg #4-28, Sheet 3 was added to summarize the sign standard.
12/16/2009	4-28 Sign Detail Revised
03/09/2010	Section 4 and Section 9 revised. 4-28 Sign Detail Revised
05/09/2011	Section 4 revised. Clarified pavement design life, added pavement marking standard Section 9 revised. Revised minimum gutter slope to 0.0065
9/9/2011	4-28 Sign Detail Revised
5/6/2013	Sections 2, 3, and 9 revised 3-2 Signature Blocks detail revised 4-28 Road Sign detail revised
1/20/2017	Sections 2, 4, 5, and 10 revised 4-17 Trenching detail revised Telecommunications details added to Section 5 8-5 Valve box detail revised
7/3/2018	Section 4 revised 4-17 Trenching detail revised 4-30 Temporary Road Closure detail added

# County of Yolo

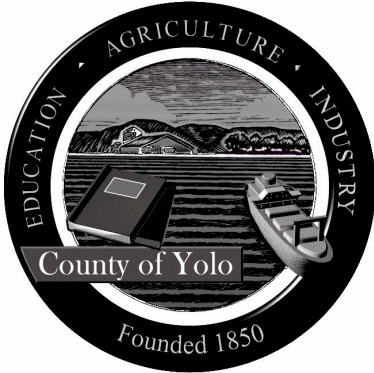

## Improvement Standards

**August 2008**

1	<b>Purpose and Definitions</b>
2	<b>General Requirements</b>
3	<b>Improvement Plan Requirements</b>
4	<b>Transportation</b>
5	<b>Street Lighting</b>
6	<b>Sound Barrier and Security Walls</b>
7	<b>Sanitary Sewers</b>
8	<b>Water Systems</b>
9	<b>Storm Drainage</b>
10	<b>Grading</b>
11	<b>Stormwater Quality, Erosion and Sediment Control</b>
12	<b>Survey Monuments</b>

**SECTION 1**  
**PURPOSE AND DEFINITIONS**

<b>CONTENTS</b>	<b>Page</b>
1-1 Purpose.....	1-1
1-2 Standard Update.....	1-1
1-3 Referenced Standards.....	1-1
1-4 Standard Forms .....	1-1
1-5 Intended Use .....	1-1
1-6 Technical Specifications .....	1-2
1-7 Construction Contractor.....	1-2
1-8 Addenda or Future Updates .....	1-2
1-9 Omissions.....	1-2
1-10 Definitions.....	1-2



## **SECTION 1 PURPOSE AND DEFINITIONS**

### **1-1 PURPOSE**

These Improvement Standards provide minimum standards for improvements to be built within County rights of way or easements, and private works that may be required as a condition for any entitlement granted by the County under Title 8 of the Yolo County Code. In particular these Improvement Standards are intended to serve as the “County Standards” referenced in Title 8, Chapter 1, Article 7. “Design Standards” of the Yolo County Code, which states “To ensure that land development shall reflect the best interests of the people of the County, all developments pursuant to the provisions of this chapter and all improvements installed in, over, or under any existing or proposed right-of-way, easement, or parcel of real property of the County in satisfaction of a condition of a variance or use permit issued pursuant to the zoning regulations (Chapter 2 of this title), or required by order of the Board of Supervisors made in a proceeding for amending said zoning regulations by changing the boundaries of any zone, or required in connection with the issuance of a building permit, shall conform to the standards of design of this chapter and the County Standards as set forth by resolution of the Board of Supervisors. (§ 6.40, Ord. 546, as amended by §§ 1 and 3, Ord. 617)” Project-specific conditions of approval or mitigation monitoring and reporting program requirements approved by the Board of Supervisors may result in more stringent requirements than provided for in these Improvement Standards.

These Standards are necessary to provide for coordinated development of required facilities to be used by the public. These Standards shall serve to regulate and guide the design, preparation of plans, construction, repair, and alteration of: streets, highways, alleys, site access, storm drainage, sewerage, water supply facilities, street lighting and related public improvements, and set guidelines for similar private works. These Standards do not apply to improvements to be dedicated to, and maintained by jurisdictions with their own standards including any Community Service District, City, State, or other governmental entity.

### **1-2 STANDARDS UPDATE**

These Improvement Standards replace the “Yolo County Improvement Standards and Specifications” dated February 1990.

### **1-3 REFERENCED STANDARDS**

These standards reference the Caltrans Standard Specifications, latest edition, and Caltrans Standard Plans for Construction of Local Streets and Roads, Caltrans Highway Design Manual, and Caltrans Traffic Manual, latest editions, the Standard Plans for Public Works Construction (“Greenbook”, published by BNi Building News), and the American Association of State Highway and Transportation officials (AASHTO) “A Policy on Geometric Design of Highways and Streets” latest edition. Caltrans documents can be downloaded from the Engineering Service Center web site at <http://www.dot.ca.gov/hq/esc>.

### **1-4 STANDARD FORMS**

Standard forms are provided for reference and use by Department staff, Consultants and Developers. Many of these forms will require editing based on project specific requirements.

### **1-5 INTENDED USE**

These Improvement Standards are intended to provide minimum standards. The appropriate use of these Standards is the responsibility of the registered engineer in responsible charge of the design. Nothing in

these Standards is intended to relieve the Developer or Design Engineer from the responsibility for providing a complete design, or specifying more stringent requirements when site conditions warrant.

At the County Engineer's discretion, these Standards may be modified if the Standards do not appear to be in the County's best interest. On a case-by-case basis, and for sound engineering reasons, minor modifications may be made to these Standards. In all such cases, the County Engineer shall approve any such variations from these Standards.

## **1-6 TECHNICAL SPECIFICATIONS**

The portions of these Standards that define the materials, work methods, quality and quantity for construction of any publicly maintained improvements shall apply to all construction contracts whether public or private. Public contracts include contracts typically between the County of Yolo and a construction contractor. Private contracts include contracts typically between a private party, such as a Developer, Land Owner, Home Owner, etc., and a construction contractor.

## **1-7 CONSTRUCTION CONTRACTOR**

All contractors performing work on improvements to be reviewed and approved for acceptance and maintenance by the County of Yolo, shall be constructed by Contractor(s) duly licensed, bonded and insured in accordance with the laws of the State of California and County requirements.

## **1-8 ADDENDA OR FUTURE UPDATES**

Future addenda or updates to these Standards will be noted in the "Addenda and Updates" sheet preceding this Section. The Improvement Standards on the County's website will be periodically updated, or new hard copies can be purchased directly from the Department.

## **1-9 OMISSIONS**

Any items or situations not included in these Improvement Standards shall be designed in accordance with general standard of care for engineering practice, as approved by the County Engineer. The following may be used as guidelines: Standard Plans for Public Works Construction ("Greenbook"), the Caltrans "Highway Design Manual," the Caltrans Standard Plans for Construction of Local Streets and Roads, and Caltrans "Traffic Manual," latest editions.

## **1-10 DEFINITIONS**

When the following terms or titles are used in these Standards or in any document or instrument where these Standards govern, the intent and meaning shall be as herein defined:

- A. **Board** – Shall mean the Yolo County Board of Supervisors.
- B. **Caltrans (or State) Standard Plans or Caltrans Standard Specifications** – Shall mean the Standard Specifications and Standard Plans of the State of California, Department of Transportation, latest edition.
- C. **Design Engineer** – Shall mean any person or persons, firm, partnerships or corporation legally authorized to practice civil, mechanical or electrical engineering in the State of California as set forth in Section 6700 et. Seq. of the Business and Professions Code of the State (Professional Engineers Act) who prepares or submits improvements plan and specifications to the Department for approval.

- D. County Code** – Shall mean the Yolo County Code as adopted and periodically updated by the Board of Supervisors. The Yolo County Code is available online at the County website.
- E. County Engineer** – An engineer designated by the Director to act as County’s plan approval agent who is legally authorized to practice civil engineering in the State of California as set forth in Section 6700 et. Seq. of the Business and Professions Code of the State. (Professional Engineers Act)
- F. Department** – shall mean the County of Yolo, Department of Planning and Public Works, including wherever used in reference specifications or plans.
- G. Developer** – Shall mean any person or persons, firms, partnership, corporation or, combination thereof, financially responsible for the work involved.
- H. Development** – Shall mean the act, process, or result of any land division, land grading, utility installation, street or building construction on property.
- I. Digital Submittals or Electronic Files** – Shall mean data files prepared using appropriate software saved and transmitted in their native format for Department use and records.
- J. Director** – Shall mean the Director of the Department of Planning and Public Works acting either directly or through an authorized representative.
- K. “Greenbook” Standard Specifications and Standard Plans** – Shall mean Standard Specifications, latest edition, and Standard Plans for Public Works Construction, latest edition, written by Public Works Standards, Inc., published by **BNI**® Building News.
- L. Inspector** – Shall mean the County’s field representative observing the Developer’s construction activities.
- M. Laboratory** – Shall mean a Caltrans-certified testing agency or testing firm that has been approved by the Planning and Public Works Department to perform quality control testing of construction performed in the County right of way.
- N. Mitigation Monitoring and Reporting Program (MMRP)** – An environmental mitigation program administered by the Department in accordance with County Code or Conditions of Approval adopted by the Yolo County Board of Supervisors.
- O. Public Works Agency** – Shall mean the Department of Planning and Public Works of the County of Yolo.
- P. Special District or Community Service District** – Shall mean a district formed for the purposes of providing public services as defined in the formation documents, which may include, but are not limited to sewer, water, storm drainage, fire, and street lighting services, and governed by an independent Board of Directors.
- Q. Standard Construction Specifications** – Shall mean the latest of the “Greenbook” Standard Specifications (latest edition), and as modified, governing the construction of roads, streets, sanitary sewers, storm drainage, concrete structures, water supply, traffic signals, street lighting and other facilities within the County of Yolo to be accepted by the Department or other Agency for maintenance or operation; also including private grading, erosion control, drainage, and landscaping.

- R. Standard Drawings** – Shall mean the standard drawings included in these Design Standards and the referenced Standard Plans for other details not included herein.
- S. State** – As used in the State Specifications, shall mean County of Yolo.
- T. Urban Area** – Shall mean any area planned for urban development by the appropriate General Plan.

**SECTION 2**  
**GENERAL REQUIREMENTS**

<b>CONTENTS</b>	<b>Page</b>
2-1 Engineer Required .....	2-1
2-2 Plans Required .....	2-1
2-3 Reference To County Improvement Standards.....	2-1
2-4 Work In County Rights Of Way, Easements And Waterways .....	2-1
2-5 Initial Plan Submittal Requirements .....	2-1
2-6 Improvement Plans Resubmittal .....	2-3
2-7 Plan Check And Inspection Fee.....	2-3
2-8 Plans Approval.....	2-3
2-9 Approved Plans Required .....	2-4
2-10 Subdivision Improvement Agreement Required .....	2-4
2-11 Improvement Plans Revisions During Construction.....	2-5
2-12 Record Plans .....	2-5
2-13 Conflicts, Error And Omissions.....	2-6
2-14 Change In Design Engineer .....	2-6
2-15 Special District Improvements And Submittals.....	2-6
2-16 Special District Annexation .....	2-6
2-17 Boring And Jacking Safety Requirements .....	2-6
2-18 Existing Utilities .....	2-7
2-19 Partial Plans .....	2-7
2-20 Inspection Requirements.....	2-7
2-21 Acceptance of Improvements .....	2-9

## **SECTION 2 GENERAL REQUIREMENTS**

### **2-1 ENGINEER REQUIRED**

A Design Engineer shall prepare all plans and specifications for engineering works requiring County approval or permits. All design work shall be performed in accordance with these Improvement Standards and in accordance with the standard of practice for the particular branch of engineering.

Pursuant to the California Business and Professions Code, Sections 6746 and 6747, improvement plans for work performed by communications companies or public utilities under the jurisdiction of the California Public Utilities Commission are not required to be prepared by a Design Engineer.

### **2-2 PLANS REQUIRED**

Complete plans for all proposed streets, highways, bikeways, alleys, site access, grading, earthwork, erosion control, storm drainage facilities, sewer collection, treatment and disposal facilities, water supply and distribution systems, street lighting, traffic control devices, underground utilities, landscaping, and any other improvement required by the project approvals, including any necessary design calculations, reports, dedications, and easements, shall be prepared by the Developer and submitted to the Department for approval. Exceptions may be made for minor work such as replacing infrastructure, connections to existing utilities, and related utility work, as determined by the County Engineer.

### **2-3 REFERENCE TO COUNTY IMPROVEMENT STANDARDS**

The General Notes of all plans shall include the following note:

“Unless shown or specified otherwise, all construction and materials shall comply with the latest edition of the Yolo County Improvement Standards.”

The Design Engineer shall be responsible for providing specific references on the plans to other standard specifications for construction features that are not included in these Improvement Standards.

### **2-4 WORK IN COUNTY RIGHTS OF WAY, EASEMENTS AND WATERWAYS**

The following are required prior to working within County rights-of-ways and easements:

- A. Possession of a complete set of Department approved improvement plans shall be required prior to performing work in Yolo County rights of way and easements.
- B. A valid encroachment permit issued by the Department shall be required prior to performing work in Yolo County rights of way as provided for in the California Streets and Highways Code, Section 1460 et. Seq., unless such work is performed under a Subdivision Agreement with the County as defined in Section 8-1.342 of the Yolo County Code.
- C. The work shall be secured with a bond or other security, as required by Sections 8-1.1004 and 8-1.1501(a) of the Yolo County Code.

### **2-5 INITIAL PLAN SUBMITTAL REQUIREMENTS**

The initial submittal of improvement plans shall be made to the Department. The initial submittal shall consist of the following, but is not be limited to:

- A.** Payment of deposit toward the actual cost of plan review as required by the Master Fee Resolution, and submittal of the necessary application to establish a reimbursable work order.
- B.** The names, addresses and telephone numbers of the Developer and the Design Engineer.
- C.** One copy of the final “Conditions of Approval”, including the Tentative Map and accompanying items as listed in the [Yolo County Code](#) and the ‘Master Checklist for Final Map, Parcel Map, and Improvement Plan Submittals.’
- D.** One copy of the mitigation measures for the Development, including related maps and plans, and any other discretionary planning actions for the subject site and development.
- E.** Three sets of plans and project specifications, complete and in accordance with these Improvement Standards.
- F.** Supporting design studies, reports, calculations, plans, computations, and test data.
  - a. Hydrology and Hydraulics calculations and reports for Storm Runoff, including watershed map.
  - b. Sewer System Calculations and shed map.
  - c. Water System Network Analysis and maps.
  - d. Geotechnical Report describing subsurface condition, soil bearing capacity, groundwater levels, soil drainage characteristics, soil erodability characteristics, and containing recommendations for earth grading and compaction, road structural design based on R-value tests, boring logs, soil corrosivity, ground water, etc., as required to meet project needs and conditions. Additional information may be required by the Chief Building Official.
  - e. Street Lighting System Design.
  - f. Other material requested by the County Engineer.
- G.** Cost estimates for all onsite and offsite improvements for the purpose of determining the amount of the Improvement Security. Cost estimates shall be based on the costs of construction as would be incurred by the County in the public bidding process, and shall include a minimum 15% construction cost contingency, and a minimum 20% allowance for project administration costs. (Final cost estimates sealed by Design Engineer shall be reviewed by the County Engineer prior to the approval of a Parcel or Final Map.)
- H.** Parcel or Final Map submittal and accompanying items to be reviewed concurrently by the County Surveyor.
- I.** Copy of utility letters in accordance with Section 2-18.
  - a. Joint Trench Plans must be submitted prior to approval of Improvement Plans and/or recordation of a related Map.
  - b. All joint trenches designed and installed by the Developer shall include spare conduit(s) (e.g., for fiber optic or other telecommunication lines) and appurtenances as required by

the Yolo County General Services Department, and be installed to General Services Department Standards and Section 5. These spare conduit(s) and associated facilities shall be owned, operated, and maintained by the Yolo County General Services Department.

- J. Copies of permits as required by other agencies.
- K. Digital files as requested during plan review process. Digital files for all plans, maps, and other supporting documents required prior to final approval.
- L. Copies of rights-of-entry from adjacent properties required for access or construction activities.

Additional copies of any submitted items shall be provided as requested by the Department.

Should there be required alterations or revisions to the plans as submitted, the County Engineer will return one copy with the corrections marked or indicated thereon. If the plans submitted are not prepared in accordance with these Improvement Standards or are not in keeping with the standards of the profession, the County Engineer may return them unmarked and unapproved.

## **2-6 IMPROVEMENT PLANS RESUBMITTAL**

The County Engineer shall indicate the number of plan sets to be resubmitted. The Design Engineer shall notify the County Engineer in writing if plans being resubmitted contain revisions or alterations other than those required by the County Engineer on prior plan reviews. Revision notations shall not be shown on plans for revisions made prior to the County Engineer's approval of the plans.

## **2-7 PLAN CHECK AND INSPECTION FEE**

The required plan check fees and inspection fees shall be determined in accordance with the Yolo County Master Fee Resolution.

Should the development not be carried to completion, any portion of the required deposit over and above the accumulated costs expended by the Department on the development will be refunded to the Developer. Failure of a Developer to complete a project does not relieve the Developer from being responsible for all costs incurred by the County.

The Developer is responsible for notifying the Department of any change of billing address, ownership or design consultants.

## **2-8 PLANS APPROVAL**

Plans shall not be considered approved, nor shall construction be authorized, until the County Engineer signifies plan approval by signing every sheet of the set of plans. The County Engineer will sign the plans after the Design Engineer has made all the necessary revisions, signed and stamped the original plans, fees have been paid and any other related project requirements, such as, but not limited to, conditions of approval, have been fulfilled.

For a Final Map or Parcel Map that requires Improvement Plans approval, the approval process will generally consist of the following:

- A. Final Map, Improvement Plans and supporting documentation are submitted to the Department for review.
- B. Comments are returned to the Developer or Design Engineer.



- C. Corrected documents are re-submitted to the Department. This step and the previous one are repeated until the Map, Plans, and supporting documentation meet County requirements.
- D. The Department prepares the Subdivision Agreement for review by the Developer. Developer returns comments and Department revises as appropriate, in consultation with County Counsel.
- E. Developer submits final corrected Improvement Plans and Final Map to Department for County Engineer's approval and County Surveyor's approval, respectively. Developer submits executed Subdivision Agreement, including improvement security and material payment security, insurance certificates, fees, deeds, etc.
- F. Providing all Conditions of Approval for the Final Map have been satisfied by the Developer, the Department prepares agenda item for a subsequent Board of Supervisors meeting, to present the Improvement Plans, Final Map, and Subdivision Agreement to the Board of Supervisors.
- G. If the Board of Supervisors approves the agenda item, a copy of the approved Plans are released to Developer (signed originals remain with the County), the Map is signed by the County Surveyor and Director, forwarded to the Recorder, and the Agreement is executed. A grading permit may be issued following Board of Supervisors' approval.
- H. Developer schedules pre-construction meeting with Department staff, other Agency staff, utility staff, Developer's Contractor, material testing lab, consultants and other appropriate personnel representing the Developer during construction.
- I. Construction on the site may begin following the pre-construction meeting.
- J. Developer and County hold periodic meetings to discuss and resolve any issues arising during construction.

The County Engineer's plan approval is valid for a period of twelve months. Should Board of Supervisors' approval not be obtained within a 12-month period, or, in the case of work not requiring Board of Supervisors' approval, the work does not commence within a 12-month period, the plans shall be resubmitted for re-approval.

## **2-9 APPROVED PLANS REQUIRED**

The Developer shall provide the Contractor with properly approved plans. The County Engineer shall have the authority to order any Contractor to cease work on any project if said Contractor does not have properly approved plans in their possession.

The cost of additional copies or reduced copies of approved plans that may be required by the County shall be provided at the Developer's cost.

## **2-10 SUBDIVISION IMPROVEMENT AGREEMENT REQUIRED**

Concurrently with the Board of Supervisors' acceptance of the final map, the Developer shall enter into an agreement with the County agreeing to complete the public improvements within the time specified in the agreement. Such agreement shall provide a clause guaranteeing the workmanship and materials provided in all improvements for a twelve (12) months period after acceptance of the improvements by the Board of Supervisors.

To assure that the improvements required by the County Code, these Improvement Standards, and the approved improvement plans are satisfactorily completed, the subdivision improvement agreement shall be accompanied by improvement securities furnished by the Developer for the cost of the improvements. Such securities shall include a Performance Bond in the amount of one hundred percent (100%) of the

engineer's estimate as approved by the County Engineer, and a Labor and Materials Payment Bond in the amount of one hundred percent (100%) of the engineer's estimate. Prior to acceptance of the improvements by the Board of Supervisors, the Developer shall furnish a warranty bond not less than fifteen (15%) percent of the engineer's estimated cost of the public improvements.

### **2-11 IMPROVEMENT PLANS REVISIONS DURING CONSTRUCTION**

Should changes become necessary during construction, the Developer shall first obtain the consent of the County Engineer and shall then resubmit the title sheet and the plan sheets affected for approval. The changes on the plans shall be made in the following manner:

- A. The original design shall not be eradicated from the plans but shall be lined out.
- B. In the event that eradicating the original design is necessary to maintain clarity of the plans, approval must first be obtained from the County Engineer.
- C. The changes shall be clearly shown on the plans with the changes and approval noted on the revision signature block, conforming to Standard Drawing 3-1.
- D. The changes shall be identified by the revision number in a triangle delineated on the plans adjacent to the change and on the revision signature block.

Minor changes that do not affect the basic design may be made upon the written authorization of the County Engineer, but said changes must be shown on record plans when the contract is completed.

The County Engineer may specify changes to the plans required to complete the necessary facilities, to be completed by the Developer. Changes to the plans ordered by the County Engineer shall conform to all of the above.

### **2-12 RECORD PLANS**

The Developer shall be responsible for keeping accurate records of all deviations from the plans. These records shall be utilized along with the Inspector's records to prepare a complete and accurate set of Record Plans ("As-Builts").

Field measurement and certification by the Design Engineer of all final grades shown on the improvement plans, including the finished pad elevations of subdivision lots, inverts, rims, grates, top of curb at changes in vertical alignment, toe and top of slope on all finished storm drain detention basins, and any other designed and constructed parameters as required by the County Engineer, shall be required prior to final acceptance of the subdivision improvements. Building pad elevations shall be constructed to within 0.2 foot of their elevation indicated on the approved plans, and all other improvements shall be constructed to within 0.1 foot of their elevation indicated on the approved plans. Certification shall comply with Section 10-8. Constructed slopes of flowlines for pipes, channels and gutters shall not be less than 95% of the slope specified on the approved plans.

Before final acceptance of the completed improvements, the Developer shall submit one bond, 24"x36", copy of the Record Plans to the County Engineer. Following review of the copy of the Record Plans by the County Engineer, final Record Plans shall be submitted to the Department on 24" x 36" polyester film sheets (Mylar®, or equivalent) with matte finish.

### **2-13 CONFLICTS, ERRORS AND OMISSIONS**

Excepted from the County Engineer's Improvement Plan approval are any features of the plans that are contrary to, in conflict with, or do not conform to, any California State Law, [County Code](#) or Resolution, conditions of approval, or generally accepted good engineering practice, in keeping with the standards of the engineering profession, even though such errors, omissions or conflicts may have been overlooked in the Department's review of the plans.

### **2-14 CHANGE IN DESIGN ENGINEER**

If the Developer elects to have a registered civil engineer or licensed land surveyor, other than the Design Engineer who prepared the plans, provide the construction staking, he shall provide the County Engineer in writing the name of the individual or firm one week prior to the staking of the project for construction. The Developer shall in all cases be responsible for:

- Verifying all construction,
- Preparation of revised plans for construction changes,
- Preparation of "as built" record plans upon completion of the construction.

In the Developer's notification of a change in the firm providing construction staking, he shall acknowledge that he accepts responsibility for design changes and "as built" information as noted above.

### **2-15 SPECIAL DISTRICT APPROVALS AND SUBMITTALS**

The Department shall also review, although not approve, Special District facilities and improvements shown on related submittals to the County. All Special District improvements shall comply with these Standards, unless the District has adopted their own standards. A Special District shall approve plans for their respective portions of the improvements prior to County approval of the plan set.

The Fire District shall approve plans showing the domestic water system improvements prior to County approval of the plan set.

The Developer is responsible for coordinating submittals to Special Districts as required to obtain the necessary approvals, prior to County approval.

### **2-16 SPECIAL DISTRICT ANNEXATION**

Any development within the sphere of influence of, or intended to be served by, a Special District shall be annexed to that District prior to the approval of Improvement Plans for any facilities to be maintained and operated by the District. Contact the Yolo County Local Agency Formation Commission for annexation procedures. The Developer shall provide evidence of annexation to the Department.

### **2-17 BORING AND JACKING SAFETY REQUIREMENTS**

Any boring or jacking operation involving an opening greater than 30 inches in diameter is subject to the State of California Division of Industrial Safety's tunnel safety requirements. The Design Engineer shall submit to the State Division of Industrial Safety plans and specifications applicable to the tunnel operation, with a letter requesting tunnel classification, prior to bidding the project. The letter should identify the Department responsible for the project, and the Department's mailing address. The plans

shall identify underground utilities and tanks or areas for storing fuel and toxic gases in the vicinity of the tunnel site, and a description of the historical land use in the area. The request for classification should be submitted allowing ample time for the Division of Industrial Safety review in order that any special requirements can be included in the project plans and specifications.

**2-18 EXISTING UTILITIES**

All existing utilities are to be shown on the plans. The Design Engineer shall submit prints of the preliminary and approved plans to the utility companies involved. Copies of the transmittal letters to the utility companies shall be provided to the County Engineer. The Developer shall make necessary arrangements with the serving utilities to properly plan for any relocation and undergrounding of existing utilities, and for the required expansion to serve the development.

All existing overhead utilities adjacent to, or in, a Development shall be placed underground. All utility services within a Development shall be placed underground.

**2-19 PARTIAL PLANS**

Where the improvement plans submitted cover only a portion of ultimate development, the plans submitted shall be accompanied by the approved plans of the ultimate development. The approved plans shall show topographic features of the ultimate development at an adequate scale to clearly show the proposed improvements.

**2-20 INSPECTION REQUIREMENTS**

Any public improvements which will be maintained by the County, or which are constructed within a County right of way or easement, shall be inspected during construction by the County Engineer, or designee. Each phase of construction shall be inspected and approved by the County Engineer prior to proceeding to subsequent phases.

The Developer shall be responsible for the cost of the services of a materials testing laboratory as defined in Section 1-10M. Inspection shall include a materials and field testing program to document compliance with the approved Plans. The scope and frequency of testing shall be determined by the County Engineer, but at a minimum shall comply with Table 1.

<b>Table 1 - CONSTRUCTION QUALITY ASSURANCE TESTING</b>		
<b>ITEM</b>	<b>TYPE OF TEST</b>	<b>FREQUENCY</b>
Trench backfill	ASTM D1557–Moisture/density curve	One per soil type encountered.
	ASTM D1557 – Relative Compaction	Field tests: Each lift: every 200 square feet, at each lateral, and 3 per intersection.
Subgrades	ASTM D1557–Moisture/density curve	One per soil type encountered.
	ASTM D1557 – Compaction	Field tests: Each lift: every 2400 sq. feet.
	Proof roll	Prior to paving with fully loaded, 3 axle, water truck, 4000 gallon minimum

Aggregate Bases	ASTM C136-Sieve Tests ASTM D1557-Moisture/density curve ASTM D1557- Relative Compaction Proof roll	One per source material One per source material Field tests: Each lift: every 2400 sq. feet. Prior to paving with fully loaded, 3 axle, water truck, 4000 gallon minimum
Asphalt Concrete	CTM 375 – In-Place Density ASTM D1557 Temperature Lift thickness Cross slope Smoothness	One per 4 hours of production As required for verification Continuous observation Cores as directed Water test, no birdbaths Profilograph, straightedge per Caltrans Standard Specifications 39-6.06
Concrete	Compressive Strength-ASTM C39/31 Slump-ASTM C143 Temperature/Time- ASTM C1064 Flowline grades Smoothness and finish	One set of cylinders per 25 cubic yards As required to verify compliance Continuous Water test, no birdbaths Straightedge per Caltrans Standard Specifications 73-1.06
Water Lines	Leakage - Pressure Test	All lines, refer to Section 8
Sewer manholes	Leakage - Pressure Test	All lines following aggregate base (AB) placement, prior to paving, refer to Section 7
Sewer lines	Leakage - Pressure Test Cleanliness/sags - TV camera	All lines following AB placement, prior to paving, refer to Section 7 Following AB placement, prior to paving
Sewer Laterals (Services)	Leakage - Pressure Test Cleanliness/sags - TV camera	All lines following AB placement, prior to paving, refer to Section 7 Once following AB placement, prior to paving, and once prior to final occupancy of homes

<p>ASTM: American Society for Testing and Materials Test Method</p>
---

<p>CTM: Caltrans Test Method</p>
----------------------------------

Additional testing may be required at the discretion of the County Engineer to verify that construction is in compliance with the approved plans and specifications, and these Improvement Standards. Any improvement constructed without County inspection as provided above or constructed contrary to the order or instruction of the County Engineer will be deemed as not complying with these Improvement Standards, and may be rejected by the County Engineer.

The Design Engineer shall notify the County Engineer when the Contractor first calls for grades and staking and shall provide the County Engineer with a copy of all cut sheets.

Any inspection services performed beyond normal working hours, or on weekends or holidays, either at the request of the Contractor/Developer or at the discretion of the County, shall constitute overtime inspection work. If the Contractor/Developer requests overtime inspection, such requests shall be made at least 48 hours in advance. Granting of the request to provide overtime inspection shall be at the sole discretion of the County Engineer, and is subject to the availability of inspection personnel. The inability of the County to provide overtime inspection services will require the Contractor/Developer to schedule the work during normal working hours.

The County's inspection of the work and materials shall not relieve the Developer, or the Developer's Contractor, of their obligation to construct the work in accordance with the approved plans and/or specifications, and industry standards. Work and materials not meeting the requirements of the approved plans and/or specifications may not be accepted by the County, notwithstanding that such work or materials may have been inspected by the County.

## **2-21 ACCEPTANCE OF IMPROVEMENTS**

No improvements shall be accepted by the County until all improvements required under the improvement agreement and improvement plans have been completed, including punchlists, removal of all dirt, debris, and erosion control measures, to the satisfaction of the County Engineer. The Developer shall file a Notice of Completion, and provide a copy of the filed Notice to the County, prior to acceptance of the improvements by the Board of Supervisors.

Within ten days after receiving a written request for final inspection, the County Engineer shall inspect the work. The Developer, or designee, will be notified in writing as to any particular defects or deficiencies to be remedied. The Contractor shall proceed to correct any such defects or deficiencies at the earliest possible date. After the defects and deficiencies have been completed, a second written request for inspection shall be made to the County Engineer. The County Engineer shall inspect the work to determine if the defects have been repaired, altered, and completed in accordance with the Plans.

For work performed under a Subdivision Agreement, following the County Engineer's approval of the work an agenda item will be prepared for the Board of Supervisors' acceptance of the improvements. A warranty bond in the minimum amount of 15% of the performance bond, in accordance with Yolo County Code Section 8-1.1004, shall be filed with the County Engineer prior to requesting Board of Supervisor's acceptance.

**SECTION 3**

**IMPROVEMENT PLAN REQUIREMENTS**

<b>CONTENTS</b>	<b>Page</b>
3-1 Digital Submittals .....	3-1
3-2 Paper Size And Scale .....	3-1
3-3 Drafting Standards .....	3-1
3-4 Title Sheet .....	3-1
3-5 Title Block .....	3-1
3-6 Plan Set Organization .....	3-2
3-7 Plan Details .....	3-2
3-8 Required Notes.....	3-4
3-9 Standard Drawings .....	3-6

## **SECTION 3 IMPROVEMENT PLAN REQUIREMENTS**

### **3-1 DIGITAL SUBMITTALS**

All plans shall be prepared using appropriate computer based design and drafting software. Improvement Plans shall be prepared using AutoCAD (version determined by County Engineer). Digital files of Improvement Plans and supporting documentation shall be submitted to the Department, in the file formats requested by the County Engineer, prior to approval of Improvement Plans.

### **3-2 PAPER SIZE AND SCALE**

Improvement plan submittals shall be on 24" by 36" paper. Only common engineering scales shall be used. Final submittals shall be provided to the Department on 24" x 36" polyester film sheets (Mylar®, or equivalent) with matte finish.

The County Engineer may request reduced-size plans to facilitate plan review and construction, and drawing borders may be adjusted as required.

### **3-3 DRAFTING STANDARDS**

All line work must be clear, sharp, and of appropriate weight. Letters and numerals must be Roman font, 0.1-inch minimum height, legible, well formed and sharp. Line work shall not intersect numerals showing profile elevations. Sharp solid arrowheads shall terminate dimension lines.

### **3-4 TITLE SHEET**

All improvement plans shall have the following minimum information on the title sheet, conforming to Standard Drawing 3-1:

1. Location Map,
2. Vicinity Map
3. Benchmark information
4. Sheet Index
5. Subdivision Name, Number, and Town.
6. Legend conforming to Standard Drawing 3-3.
7. Agency/Utility contacts
8. Title, signature, approval, and revision blocks conforming to Standard Drawings 3-1 & 3-2.

### **3-5 TITLE BLOCK**

Each sheet within the set of drawings shall have an approved title block placed across the bottom edge of the sheet in accordance with Standard Plan 3-1. The title block shall include the following

1. Sheet number
2. Scale
3. Date
4. Project title
5. Sheet title
6. Design Engineer's name, signature and seal.
7. Plan approval blocks (County plan approval signature block required on all sheets)
8. Revision block



### **3-6 PLAN SET ORGANIZATION**

The order of the drawings in the Plan Set shall be as follows:

1. Title Sheet
2. General Notes (with Typical Sections if space allows)
3. Overall Site Plan
  - a. Scale of drawing and scale bar
  - b. North arrow
  - c. Street names
  - d. Property lines
  - e. Public easements
  - f. Assessment or Service District limits (if applicable)
  - g. Adjacent subdivision & parcel references including names, lot lines, and lot numbers
  - h. Site access
  - i. Assessor's Parcel Numbers
  - j. NAD83 coordinates of all intersections shown.
4. Existing Topography
5. Demolition Plan
6. Overall Grading and Drainage Plan
7. Overall Utility Plan
8. Street Plan and Profile
9. Other Utility Plan and Profile
10. Erosion Control Plan
11. Detailed Grading Plan
12. Signing and Striping Plan
13. Special Details

Other specialties, such as landscaping, structural, electrical, mechanical, etc., shall be included in the plan set as appropriate.

The storm drainage, sanitary sewer, and water systems shall be shown on the street plan and profile sheets. Any underground utility not within the limits of a proposed street shall be shown on a separate plan and profile sheet.

### **3-7 PLAN DETAILS**

In addition to the other requirements of these Improvement Standards, the following details shall be shown on the plans submitted for approval. The Design Engineer and other designers are responsible for preparing neat, accurate and comprehensive plans in keeping with the standards of their profession.

**A. Record Information.** All existing and proposed:

1. Right of Way lines
2. Boundaries of lots fronting on the street (addresses of existing lots)
3. Easements
4. On-site and off-site right of way and easement lines shall be properly dimensioned.

**B. Existing Facilities.** All pertinent existing facilities shall be shown, including:

1. Street striping and signs
2. Medians including landscaping
3. Driveways (on both sides of the street when within 40 feet of the median ending)
4. Curbs
5. Sidewalks

6. Pavement shoulders
7. Location and size of all underground utilities, water, storm, and sanitary sewer lines
8. Limits of 100-year flood plains
9. Structures
10. Trees (6" and larger) and other foliage
11. Traffic signals and traffic detector loops
12. Street lights, pull-boxes, and underground electrical conduits
13. Drainage ditches
14. Utility poles
15. Fire hydrants
16. Retaining walls
17. Other features of the area which may affect the design requirements for the project.

When a potential utility conflict exists, the Design Engineer shall verify "as built" elevations for the utilities, using sub-surface investigative techniques, whether electronic or physical (excavation). For existing road structural sections, the grade of the cross slope on the road and 20 feet into the property at driveways shall be shown.

- C. Contours and Elevations.** Existing contours and supporting spot elevations shall be shown on all plans. Topographic information of existing facilities shall be extended an appropriate distance beyond the project limits for conform purposes. In general, the limits for drainage and grading purposes shall extend at least 100 feet beyond the project limits, or more if directed by the County Engineer. The limits for street striping and transportation conform shall extend at least 300 feet, or more if directed by the County Engineer.
- D. Profile.** The plans shall show the existing profile of all roadway centerline, edges of pavement, gutter flow lines, drainage ditches, storm and sanitary sewers. Designs of proposed public improvements shall include profiles showing centerline elevations at 50-foot intervals and rates of grades, vertical curves and other vertical alignment data. When curbs and gutters are designed for reconstructed roads, elevations shall be shown on the edge of the outside traveled way, or if the road has a full paved section, shall also be shown two feet from the proposed lip of gutter. Designs for vertical curves shall show elevations at 25-foot intervals. Where it exists, stationing shall be used for profiles of public roads.
- The plans shall show the existing ground profile for a minimum distance of 200 feet beyond temporary street endings to ensure proper vertical alignment within the proposed improvement limits. The 200-foot minimum shall be increased when requested by the County Engineer.
- E. Stationing and Orientation.** The stationing on plan and profile shall read from left to right. Stationing shall increase from south to north or from west to east, except for cul-de-sacs, where stationing shall proceed from the intersection. Plans shall be so arranged that the North arrow points toward the top or upper 180 degrees, insofar as practical.
- F. Bench Marks.** Location, description, and elevation of benchmarks and datum shall be clearly delineated on the plans. The datum shall be North American Vertical Datum of 1988 (NAVD88). The Design Engineer shall be responsible for locating the official benchmarks nearest their project.
- G. California Coordinates System.** Proposed improvements shall be tied into the California Coordinate System, consistent with mapping requirements for any required Parcel or Final Map. If monument coordinates are not available within a reasonable distance (1/2 mile or less) of said improvement, special consideration may be given by the County Engineer.

- H. Cross-Sections.** Cross sections shall be included in the plans where determined necessary by the County Engineer. Sections shall include all pertinent structural and topographical features. Section calls shall be identified by a number and letter and/or the sheet on which the section appears.
- I. Special Notes.** Special Notes shall be clearly indicated. Notes shall contain a statement regarding obtaining encroachment permits from other agencies when applicable.

### **3-8 REQUIRED NOTES**

The Design Engineer shall include the following notes on improvement plans submitted to the Department for approval in the appropriate location. Supplemental notes may be required.

- A.** Unless shown or specified otherwise, all construction and materials shall comply with the latest edition of the Yolo County Improvement Standards.
- B.** The Contractor shall not begin any work shown on these plans until the signature of approval of the County Engineer is affixed hereon and all applicable permits have been obtained.
- C.** The Contractor shall schedule a pre-construction meeting with County staff, other Agency staff, Contractor, material testing lab, Consultants, and other appropriate personnel representing the Developer at least 2 working days in advance of any construction activities.
- D.** Contractors shall be responsible for coordinating their operations with all required materials testing services as required by the Yolo County Improvement Standards and the County Inspector. Each phase of construction shall be tested and approved by the County Inspector prior to proceeding to subsequent phases.
- E.** Contractor shall notify all utility companies involved in the development prior to beginning of work.
- F.** Utilities to be installed under existing pavements shall be directionally bored.
- G.** No pavement work will occur within the road right-of-way prior to completion of any necessary utility pole removal and utility undergrounding work within that right-of-way
- H.** Contractor shall notify "Underground Service Alert" at 811 at least two working days before starting any excavation activities.
- I.** Materials submittals for material incorporated into the work including, but not limited to, aggregate base, asphalt concrete, and concrete materials shall be submitted to the County at least 2 weeks prior to delivery of materials to the site.
- J.** Contractor shall be responsible for the protection of all existing survey monuments and/or other survey markers during construction. All monuments or markers destroyed during construction shall be replaced by a licensed California Land Surveyor at the Contractor's expense.
- K.** Prior to requesting County acceptance of improvements, the Contractor shall set standard survey monuments at locations referenced by Engineer. All survey monuments shall be punched and shall bear the license number of the surveyor.
- L.** Contractor shall notify the appropriate Special District, after receipt of permits and payment of required fees, prior to making water or sewer taps.

- M.** Contractor is responsible for compliance with all currently applicable safety laws of all jurisdictional bodies. The Contractor is directed to contact the California State Department of Industrial Relations. The Contractor shall be responsible for all barricades, safety devices, and control of traffic within and around the construction area. For all trench excavation 5 feet or more in depth, the contractor shall obtain a permit from the California State Division of Industrial Relations prior to beginning any excavation.
- N.** Public safety and traffic control shall be provided in accordance with the Caltrans Traffic Manual and as may be directed by the County. Any lane closures (vehicle or bicycle) shall be approved in advance by the County. Safe vehicular, bicycle, and pedestrian access shall be provided at all times.
- O.** The Contractor shall maintain continuous temporary traffic barricades, with operable flashing devices, spaced at intervals of not to exceed 50 feet whenever the work area is adjacent to an existing traffic lane and there is a pavement cut, trench, or ditch which is over 2 inches in depth, or if the traffic lane used by vehicles is not paved. If the cut, trench or ditch is more than 10 feet from a traffic lane, then the barricade spacing may be greater, provided that it does not exceed 200 feet.
- P.** Contractor agrees that in accordance with generally accepted construction practices Contractor shall be required to assume sole and complete responsibility for job site conditions during the course of the construction of the project, including safety of all persons and property; that this requirement shall be made to apply continuously and not be limited to normal working hours, and Contractor further agrees to indemnify and hold the County of Yolo, its officers, employees, agents, and volunteers harmless from any and all liability, real or alleged, in connection with the performance of the work on this project.
- Q.** All construction and material delivery vehicles shall use the designated access and haul route(s) to the construction site. Route(s) is (are) (*design engineer to enter route description or reference detail*). Any deviation in route(s) shall be subject to County Engineer approval. The route(s) shall be monitored during the project for any damage and debris attributable to the project vehicles. All damage and debris as a result of the project shall be repaired per County Standards.
- R.** In the event that any street or portion of any street will be closed to emergency traffic, the Contractor shall notify Yolo County Communications Dispatch at (530) 666-8920 prior to closure, and immediately after reopening said street.
- S.** Contractor shall be responsible for conducting his operation entirely outside of any floodplain boundaries unless otherwise approved. The 100-year floodplain boundaries shall be clearly delineated in the field prior to construction.
- T.** Contractor shall be responsible for conducting his operation entirely outside of any “no grading” area. These areas shall be clearly delineated in the field prior to construction.
- U.** Where work is being done in an off-site easement the Contractor shall notify the property owner two working days prior to commencing work within said easement. Copies of all signed/approved off-site easement and/or right-of-entry documents shall be provided to the County.
- V.** Contractor shall not dispose of chlorinated or other chemically treated water into any drainage system.
- W.** Contractor shall provide evidence to County of notification of Lake or Streambed Alteration to the California Department of Fish and Wildlife, if necessary.

**3-9 STANDARD DRAWINGS**

If a variance to a standard drawing is intended, the standard drawing shall be shown with the variance clearly noted.

<b>Standard Drawings</b>		
<b>Section 3 – Improvement Plan Requirements</b>		
<b>Drawing</b>	<b>Sheets</b>	<b>Description</b>
3-1	1	Standard Title Sheet
3-2	1	Standard Signature Blocks
3-3	1	Standard Legend



NAME OF FIRE DISTRICT  
APPROVED FOR FIRE HYDRANTS  
(AS APPROPRIATE)

\_\_\_\_\_  
TITLE  
DATE APPROVED \_\_\_\_\_

NAME OF SERVICE DISTRICT  
APPROVED FOR WATER, SEWER, & STREETLIGHTS

\_\_\_\_\_  
TITLE  
DATE APPROVED \_\_\_\_\_

**YOLO COUNTY PLANNING AND PUBLIC WORKS**

Reviewed for conformance with the Yolo County Improvement Standards.  
The undersigned shall not be liable for errors and omissions on the plans.  
Approval valid for twelve months from date signed.

\_\_\_\_\_  
COUNTY ENGINEER  
P.E. C42401

\_\_\_\_\_  
DATE

NOTE: EDIT AS REQUIRED TO INCLUDE  
OTHER FACILITIES TO BE OWNED, OPERATED, AND  
MAINTAINED BY SERVICE DISTRICTS.

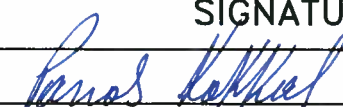
COUNTY OF YOLO PLANNING AND PUBLIC WORKS DEPARTMENT	DATE: 5/6/2013
SIGNATURE BLOCKS	SHEET # 1 OF 1
 COUNTY ENGINEER No. C42401	7 MAY 2013 APPROVAL DATE
	DRAWING #: 3-2



# LEGEND

# ABBREVIATIONS

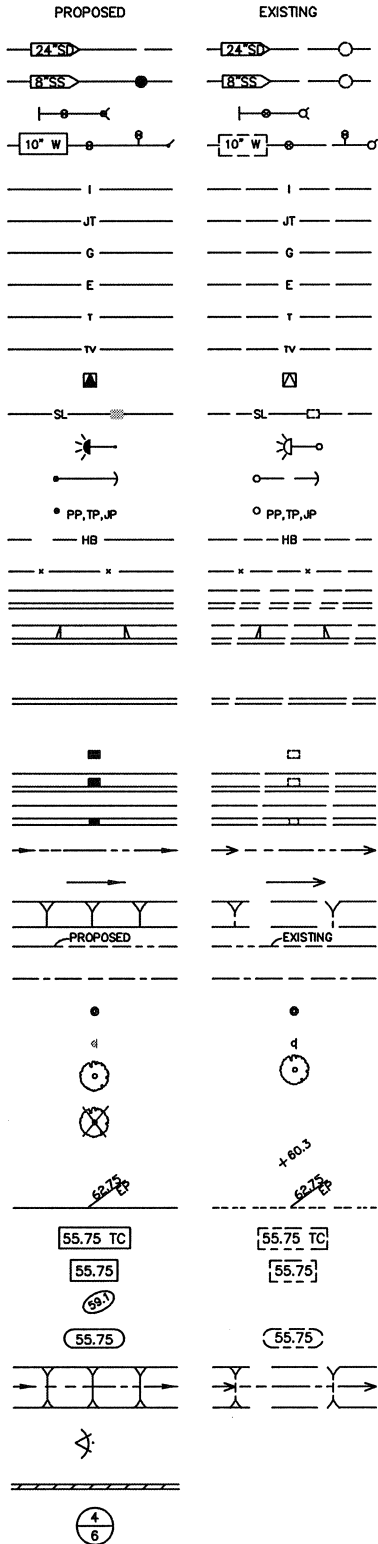

STORM DRAIN AND MANHOLE  
 SANITARY SEWER AND MANHOLE  
 FIRE HYDRANT AND VALVE ASSEMBLY  
 WATER MAIN, VALVE, AIR RELEASE VALVE & BLOWOFF VALVE  
 IRRIGATION PIPELINE  
 JOINT UTILITY TRENCH  
 GAS MAIN  
 ELECTRICAL LINE  
 TELEPHONE LINE } OH-OVERHEAD  
 CABLE TELEVISION }  
 PG & E TRANSFORMER LOCATION  
 STREET LIGHT CONDUIT, WIRING & PULL BOX  
 STREET LIGHT AND POLE  
 UTILITY POLE WITH DOWN GUY & ANCHOR  
 POWER POLE, TELEPHONE POLE, JOINT POLE  
 HEADER BOARD  
 FENCE  
 LOW PROFILE CURB, GUTTER AND SIDEWALK  
 VERTICAL CURB, GUTTER AND SIDEWALK WITH DRIVEWAY  
 CURB OR CURB AND GUTTER  
 FACE OF CURB (FC)  
 CATCH BASIN OR DRAINAGE INLET  
 CURB INLET  
 GRATE INLET  
 FLOWLINE OF DITCH OR SWALE  
 DIRECTION OF SURFACE DRAINAGE FLOW  
 CUT OR FILL SLOPE  
 RIGHT OF WAY OR PROPERTY LINE  
 STREET CENTERLINE OR BASELINE  
 SURVEY MONUMENT  
 SIGN  
 TREE  
 TREE TO BE REMOVED  
 EXISTING GROUND SURFACE ELEVATION  
 EDGE OF PAVEMENT AND ELEVATION  
 TOP OF CURB (TC) ELEVATION  
 BACK EDGE OF WALK ELEVATION  
 FINISHED GRADE OF LOT IF DIFFERENT THAN BUILDING PAD GRADE  
 FINISHED BUILDING PAD ELEVATION  
 DRAINAGE DITCH  
 ANGLE POINT  
 MASONRY WALL  
 DETAIL NO. / SHEET NO.

AB = AGGREGATE BASE  
 BC = BEGIN CURVE  
 EC = END CURVE  
 COY = COUNTY OF YOLO  
 MAX = MAXIMUM  
 MIN = MINIMUM  
 TI = TRAFFIC INDEX  
 TYP = TYPICAL  
 WWM = WELDED WIRE MESH

NOTE: ALTERNATIVE FORMATS ARE ACCEPTABLE PROVIDED ALL LINETYPES AND SYMBOLS ARE DEFINED.

<b>COUNTY OF YOLO</b> PLANNING AND PUBLIC WORKS DEPARTMENT		DATE: 08/05/08
<b>LEGEND</b>		SHEET # 1 OF 1
<i>Parred Kakkos</i> COUNTY ENGINEER No. C42401		DRAWING #: 3-3
28 AUG. 08 APPROVAL DATE		

**SECTION 4**  
**TRANSPORTATION IMPROVEMENTS**

<b>CONTENTS</b>	<b>Page</b>
4-1 Developer's Pavement, Signal, And Street Light Responsibility .....	1
4-2 Street Type and Design Width .....	2
A. Local Residential Street .....	2
B. Local Residential Low-Volume Street .....	2
C. Primary Residential Street .....	2
D. Collector Street .....	2
E. Industrial Street .....	3
F. Arterial (2-lane) Street .....	3
G. Arterial (4-lane) Street .....	3
H. Rural Street .....	4
I. Frontage Road .....	4
J. Added Width at Intersections .....	4
K. Private Streets and Driveways .....	4
L. Alleys .....	5
4-3 Right-Of-Way Width .....	7
4-4 Street Class .....	7
A. Class 'A' Street .....	7
B. Class 'B' Street .....	7
C. Class 'C' Street .....	8
D. Other Streets .....	8
4-5 Structural Section .....	8
4-6 Profile Standards .....	10
4-7 Partial Street .....	11
4-8 Offset Intersection .....	12
4-9 Driveways .....	13
4-10 Elbow Intersection .....	14
4-11 Centerline Radii .....	14
4-12 Sight Distance At Intersections .....	15
4-13 Intersection Corner Radii .....	16
4-14 Bus Stop .....	16
4-15 Sidewalk Ramp .....	16
4-16 Curb And Gutter .....	17

<b>CONTENTS</b>	<b>Page</b>
4-17 Valley Gutter.....	17
4-18 Sidewalk.....	17
4-19 Pedestrian Lane.....	18
4-20 Replacing Culverts.....	18
4-21 Trenching/Boring In Existing Paved Roadways.....	18
4-22 Testing Of Materials.....	19
4-23 Street Names.....	19
4-24 Street Sign Location.....	19
4-25 Traffic Signs.....	20
4-26 Survey Monuments.....	20
4-27 Permanent Barricade.....	20
4-28 Street Trees.....	20
4-29 Fences.....	22
4-30 Privately Owned Bridge.....	22
4-31 Vehicle Access At Street Terminations.....	22
4-32 Pavement Striping and Marking.....	22

## SECTION 4 TRANSPORTATION IMPROVEMENTS

### **4-1 DEVELOPER'S PAVEMENT, SIGNAL, AND STREET LIGHT RESPONSIBILITY**

- A. Construction of street improvements shall conform to the centerlines established by the County Engineer.
- B. Where an existing pavement section within, adjacent, or contiguous to the Developer's project does not generally meet the current structural section standard and/or the centerline grade and alignment, or existing pavement conditions are not satisfactory to the County Engineer, the Developer shall be responsible for the reconstruction of pavement section on all such streets.

The Developer shall overlay any areas beyond these limits where the design centerline grade deviates from the existing or where adjacent pavement conditions are not satisfactory to the County Engineer. The Developer shall also be responsible for overlaying any low areas where the new pavement meets the existing pavement to maintain a uniform cross slope, and overlaying areas necessary to create a smooth transition between the new and existing pavement sections. The Developer shall be responsible for repairing and overlaying areas damaged during construction.

- C. When making a connection to an existing street end, the Developer shall be responsible for removing and reconstructing the existing roadway up to a maximum of twenty feet to make a satisfactory connection as required by the County Engineer.

When making connections to existing pavement, the Developer shall be responsible for a 1-foot wide minimum sawcut of the existing pavement along with an additional 1 foot minimum by 1-1/2" deep grinding and paving. Refer to Standard Drawing 4-16. When making connections to existing new pavement (less than 5 years old), the 1-1/2" deep grinding shall extend from the lip of gutter to the lip of the gutter, or as required by the County Engineer.

- D. The Developer shall be responsible for all of the structural section and pavement on all streets within, adjacent, and contiguous to the project, including frontage roads, as required by the County Engineer. If the street is to be paved under a future Department contract, the County Engineer may require a cash deposit for the roadway and related work in lieu of actual construction and the Department shall include the work in the Department contract.
- E. All temporary approaches to existing roadways required as a result of the development shall be at the Developer's expense. The temporary approaches shall be paved with a structural section to be determined individually for each situation.
- F. The Developer shall be responsible for relocating existing traffic signals, streetlights, and utilities, and installing new traffic signals and street lights as necessary for required street improvements. Utilities shall be installed underground.
- G. The Developer shall be responsible for constructing or modifying curbed median islands where required by these Standards, including landscaping and landscaping irrigation, or when required for traffic control as a result of the development, as determined by the County Engineer.
- H. The Developer shall be responsible for installing plantings and irrigation in planter strips, and maintaining such landscaping until acceptance of the improvements. Following acceptance, maintenance of planter strips shall be the responsibility of the adjacent landowners.

- I. The developer shall be responsible for bus stops, bus turnouts, and intersection widening as shown on Standard Drawing 4-29 and in accordance with Section 4-14 of these Standards.
- J. Variances and exceptions to these Standards shall be specifically listed and requested in writing. Such requests shall be presented to the County Engineer along with substantiating evidence (plans, profiles, calculations, etc.) supporting the variance or exception. The request shall be made as early as possible in the review process and preferably prior to or concurrently with the first submittal.
- K. The Developer shall be responsible for all drainage facilities (bridges, pipes, culverts, detention facilities, and appurtenances) within, adjacent, and contiguous to the project.
- L. The Developer shall be responsible for all on-site modifications to allow for access for the disabled in accordance with the Americans with Disabilities Act including, but not limited to, sidewalk curb ramps in accordance with the Caltrans Standard Plans.

#### **4-2 STREET TYPE AND DESIGN WIDTH**

- A. Local Residential Street The Local Residential Street section is required to serve individual lots in residential subdivisions.

A Local Residential Street shall have a face-of-curb to face-of-curb width of 36 feet, with the indicated minimum right of way width and improvements in accordance with Table 4-1, Street Cross-Sections and Standard Drawing 4-1.

- B. Local Residential-Low Volume Street The Local Residential-Low Volume Street section may be used for streets serving fewer than 12 single-family dwelling units, with average lot frontage less than 100', upon the approval of the County Engineer.

A Local Residential-Low Volume Street section shall have vertical curbs, 6.5' planter strips, and a face-of-curb to face-of-curb width of 32 feet, with the minimum right of way and improvements in accordance with Table 4-1, Street Cross Sections and Standard Drawing 4-2.

- C. Primary Residential Street The Primary Residential Street section is required in residential areas in the vicinity of parks, schools, and other public facilities, in multiple family developments, and may be required elsewhere based on the County's review of the traffic circulation system.

A Primary Residential Street shall have a face-of-curb to face-of-curb width of 40 feet, with the indicated minimum right of way width and improvements in accordance with Table 4-1, Street Cross-Sections and Standard Drawing 4-3.

- D. Collector Street The Collector Street section is required in residential areas where traffic flows are projected to exceed 3000 vehicles per day, and in commercial areas.

Collector Streets shall have a face-of-curb to face-of-curb width of from 40 feet to 64 feet. The width shall be determined by the County Engineer considering the volume of traffic expected, the need for turn lanes, parking, bicycle lanes, and pedestrian facilities. The right of way width and improvements shall be in accordance with Table 4-1, Street Cross-Sections and Standard Drawing 4-4. Additional right of way and pavement shall be provided at intersections for acceleration, deceleration, bus turnouts, and turn lanes, as specified by the County Engineer.

- E.** Industrial Street The Industrial Street section is required in industrial areas, or in commercial areas where a large proportion of the traffic is expected to be trucks.

Industrial Streets shall have a face-of-curb to face-of-curb width of from 48 feet to 64 feet, depending on the volume of traffic expected and the proportion of truck traffic expected. The indicated minimum right of way width and improvements shall be in accordance with Table 4-1, Street Cross-Sections and Standard Drawing 4-5.

- F.** Arterial (2-lane) Street The Arterial (2-lane) Street standard may be required in commercial developments when warranted to provide a continuous center turning lane or raised landscaped median. The Arterial (2-lane) Street standard shall be required when shown on a Transportation, Circulation or Street Master Plan or when required by the project traffic analysis.

An Arterial (2-lane) Street shall have the indicated minimum right of way width and improvements in accordance with Table 4-1, Street Cross-Sections and Standard Drawing 4-6. The street section shall have Class 1 off-street bike paths when warranted or required by the project approvals. Refer to Section 4-2(J) "Added Width at Intersections" for intersection widening requirements.

Arterial (2 lane) Streets shall have a solid non-traversable landscaped median between cross street intersections.

Minor street intersections (with right turns only) should be no closer than 450 feet from each other or from the cross street intersections. Major driveways which will serve significant traffic volume, as determined by the County Engineer, shall be considered as intersecting streets and shall be no closer than 450 feet from each other or from cross street intersections. All other driveways shall have right turns only. Driveways should be located as far apart as practical with a minimum of 150 feet between driveways or from driveways to intersections. Major driveways that will be signalized shall be designed in accordance with public street intersection standards.

All arterial streets shall be designed to the appropriate arterial standards regardless of whether or not they are apparent on a Transportation, Circulation or Street Master Plan. Where streets are constructed with the arterial standard widths, it is intended that they meet all the standards specified herein.

All arterial streets shall be subject to full or partial access control (relinquishment of access rights by abutting properties) at the discretion of the County Engineer.

- G.** Arterial (4-lane) Street – The Arterial (4-lane) Street standard may be required in developments when warranted to provide a continuous center turning lane or raised landscaped median. The Arterial (4-lane) Street standard shall be required when shown on a Transportation, Circulation or Street Master Plan or when required by the project traffic analysis.

An Arterial (4-lane) Street shall have the indicated minimum right of way width and improvements in accordance with Table 4-1, Street Cross-Sections and Standard Drawing 4-7. The street section shall have Class 1 off-street bike paths when warranted or required by the project approvals. Refer to Section 4-2(J) "Added Width at Intersections" for intersection widening requirements.

Arterial (4-lane) Streets shall have a solid non-traversable landscaped median between cross street intersections. Median openings shall be spaced at least 650 feet apart.

Minor street intersections (with right turns only) should be no closer than 450 feet from each other or from the cross street intersections. Major driveways (those with left turn movements) which will serve significant traffic volume, as determined by the County Engineer, shall be considered as intersecting streets and shall be no closer than 650 feet from each other or from cross street intersections. All other driveways shall have right turns only. Driveways should be located as far apart as practical with a minimum of 150 feet between driveways or from driveways to intersections. Major driveways that will be signalized shall be designed in accordance with public street intersection standards.

All arterial streets shall be designed to the appropriate arterial standards regardless of whether or not they are apparent on a Transportation, Circulation or Street Master Plan. Where streets are constructed with the arterial standard widths, it is intended that they meet all the standards specified herein.

All arterial streets shall be subject to full or partial access control (relinquishment of access rights by abutting properties) at the discretion of the County Engineer.

- H.** Rural Street The Rural Street section is required in rural areas where Class C street improvements (see Section 4-4) are allowed.

A Rural Street shall have a minimum width of 32 feet in accordance with Table 4-1, Street Cross-Sections and Standard Drawing 4-8. Driveway connections to Rural Streets shall comply with Standard Drawing 4-23.

- I.** Frontage Road A street which provides service to abutting property and control of access alongside another street for which direct access is prohibited or undesirable. Frontage roads adjacent to State freeways shall conform to the full width standards for secondary collector streets, except the sidewalk may be omitted on the freeway side.

- J.** Added Width at Intersections Additional width shall be added for dedicated right turn lanes, additional left turn lanes, deceleration/transition lanes, as required by project approvals and (any) traffic impact study. All such width additions shall be subject to review and approval by the County Engineer.

All major streets shall be required to accommodate “U” turns at all traffic signals. A minimum outside clear path radius of 44 feet of pavement shall be required.

- K.** Private Streets and Driveways Private streets serving three (3) or more parcels with an average size of 5 acres or less, shall comply with the County Street Type and Design Width appropriate for the planned use, as determined by the County Engineer. The visibility requirements at private road intersections shall comply with Standard Drawing 4-13.

Access to a single parcel shall be provided via a driveway meeting the requirements of Section 4-9, and Standard Drawing or 4-23, depending on the street class (refer to Section 4-4), and the visibility requirements shown in Standard Drawing 4-13.

In all cases, access shall be provided that meets the requirements of the local fire district, or the requirements of California Code of Regulations, Title 14, Division 1.5, Chapter 7, “Fire Protection”, whichever is more stringent.

- L.** Alleys Where alleys exist and are to be utilized to access existing lots, alleys shall be graded to drain and paved with 3 inches of hot mix asphalt pavement compacted to 96% relative compaction over 8 inches of aggregate base compacted to 95% relative compaction over native subgrade compacted to 95% relative compaction.
- M.** All compaction levels specified in these Standards, including those called out on the various Standard Drawings, shall be relative compaction, as determined by the test methods specified in Section 2-20, Table 1.





### **4-3 RIGHT-OF-WAY WIDTH**

Building setbacks, landscaping requirements, and parking requirements shall be based on the ultimate right-of-way width regardless of the location of existing public street improvements or right-of-way lines. In case of conflict with any zoning code requirements, the higher standard shall apply.

The right of way and street widths shown in these Standards are intended for new streets. Where existing streets are to be extended, or where additional dedications are to be made along existing streets, the County Engineer shall consider conditions along the existing street when determining new right of way and street widths, and shall strive to maintain consistency of right of way and street widths in existing corridors.

### **4-4 STREET CLASS**

#### **A. Class 'A' Street**

Class 'A' Streets shall be provided in all developments having a net average parcel size of not more than 14,500 square feet (1/3 acre) per lot.

Developments on land zoned or used for duplex, multi-family residential, business and professional, commercial, and industrial uses shall require Class 'A' street improvements, regardless of the individual lot area.

Class "A" Streets shall consist of:

- a. Hot mix asphalt pavement on aggregate base and subbase (as required). Rigid and semi-rigid pavement structures may be used upon approval by the County Engineer.
- b. Concrete curb, gutter, and sidewalk, including landscaped planter strips and/or medians, as may be required.
- c. Side slopes not steeper than 3:1 (horizontal:vertical) or a reinforced concrete or masonry retaining wall beginning at the right of way line. Pedestrian railing may be required along sidewalks when the adjacent property slopes down from the street.
- d. Street lights in accordance with Section 5.
- e. Other required utility improvements in accordance with the appropriate sections of these Standards as appropriate, all of which shall be placed underground.

#### **B. Class 'B' Street**

Class 'B' Streets shall be provided in all residential developments having a net average parcel size of more than 14,500 square feet (1/3 acre) but less than 20,000 square feet (0.46 acre), per residential lot.

Class 'B' Streets shall be the same as Class 'A' Streets except that sidewalks may be omitted.

**C. Class ‘C’ Street**

Class ‘C’ Streets shall be provided in all residential developments having a net average parcel size of more than 20,000 square feet (0.46 acre) per residential lot.

Class ‘C’ Streets shall be the same as Class ‘A’ Streets except that sidewalks, curbs, and gutters may be omitted.

**D. Other Streets**

Streets or roads which do not fall into any of the above classifications shall be considered as individual cases, with determinations as to the appropriate level of improvement determined by the County Engineer. In these cases the minimum lane width shall not be less than twelve feet (12’) and the minimum shoulder width shall not be less than four feet (4’).

**4-5 STRUCTURAL SECTION**

The following standards for the design of structural sections shall govern the preparation of plans for proposed improvements.

- A.** Structural sections for all roadways 20 feet or wider shall be designed to conform to the California Department of Transportation Highway Design Manual (latest edition), "Chapter 630 – Flexible Pavement" or other method as approved by the County Engineer. The gravel equivalent shall be increased by a factor of safety of 1.35 for TI’s less than or equal to 9, and increased by a factor of 1.25 for TI’s greater than 9.
- B.** The minimum traffic indices (T.I.) used for the calculation of the roadway structural sections shall be based on a 20-year design life and shall comply with Table 4-2.

<b>TABLE 4-2 MINIMUM TRAFFIC INDEX</b>	
<u>Street Type</u>	<u>Minimum Traffic Index (20 year)</u>
Local Residential Streets	5.0
Primary Residential	6.0
Collector Streets	7.0
Residential Cul-de-Sacs	6.5
Industrial Streets	9.0
Arterial (2-lane) Streets	9.0
Arterial (4-lane) Streets	10.0

T.I.'s will be provided to the Design Engineer for industrial cul-de-sacs, locations where high volumes of truck traffic are anticipated, or other unique conditions, and shall be approved by the County Engineer.

- C. A soil report indicating the R-value of subgrade or basement soil, along with calculations for structural pavement sections, shall be submitted with any plan indicating construction of roadways. Samples of soils for R-value tests shall be taken on the following basis:
1. 3 tests minimum.
  2. The samples for testing shall be taken at the estimated depth of the grading plane.
  3. The location of the tests within the development area shall be selected such that an adequate representation of the quality of the basement soil may be tested.
  4. For development areas in excess of 50 acres, at least one additional test shall be taken for each 25 acres.

In lieu of a field sampling, an R-value of 5 may be assumed. Design thickness shall be rounded up to the next 0.05-foot increment. Minimum design thickness for hot mix asphalt pavement shall be 0.4 feet. Lime or cement stabilization treatments shall be used to stabilize the top 12 inches of subgrades with an R-value less than 20.

Minimum structural sections shall comply with Table 4-3.

<b>TABLE 4-3 MINIMUM HOT MIX ASPHALT SECTION</b>		
<u>Street Type</u>		
	<u>Hot mix asphalt</u>	
Local Residential, Primary Residential Streets	0.4 ft.	
Collector Streets	0.50 ft.	
Industrial Streets	0.50 ft.	
Arterial (2-lane) Streets	0.50 ft.	
Arterial (4-lane) Streets	0.55 ft.	
Minimum compaction of Subgrades and Aggregate Base : 95% relative compaction		
Minimum compaction of Hot Mix Asphalt: 96% relative compaction		

- D. Portland cement concrete (PCC) streets may be constructed with the approval of the County Engineer. This is not generally practiced if there are utilities underneath the pavement. Collector or Arterial intersections expected to experience higher volumes of truck or bus traffic, may be required to be paved with PCC sections throughout acceleration zones, at the County Engineer’s discretion.
- E. The use of alternate road building materials may be allowed if supported by a thorough geotechnical study consisting of field and laboratory work summarized in a geotechnical report sealed by a geotechnical engineer, and a sound pavement design study prepared by a registered civil engineer and approved by the County Engineer. Alternate road building materials may include but are not limited to the following:

1. Subgrade stabilizing and/or isolating geotextiles and grids
2. Pavement stress absorbing interlayers

3. In-situ soil and subgrade stabilizing admixtures
  4. The use of recycled materials in the manufacture of subbase, subgrade, and hot mix asphalt
  5. Rubberized asphalt concrete
  6. Subbase drainage facilities
- F.** Positive structural section drainage facilities may be required by the County Engineer if high groundwater levels indicate subbase drainage may be necessary and the basement soil has permeability less than 100 feet per day. Drainage system design shall be in accordance with California Department of Transportation Highway Design Manual (latest Edition) or other method as approved by the County Engineer. Subbase drainage shall be provided at all sag points in impermeable soils.**G.** In transition areas from one street section to another, the heavier structural section shall be used in the transition area.
- H.** The full pavement structural section shall be completed prior to issuance of building permits. In no case shall traffic be allowed on partial pavement sections, unless it has been designed for that purpose.

#### **4-6 PROFILE STANDARDS**

The following standards for the design of profiles shall govern the preparation of plans for proposed improvements. See Section 3-7(D).

- A.** The minimum grade on new streets shall be 0.65 percent (.0065) except that the minimum fall at the gutter flowline around curb returns shall be 0.5 foot. Curb and gutter elevations on crest and sag vertical curves shall be adjusted to conform to a 0.3 percent minimum grade. If minimum profile grade standards are used, a drainage analysis shall be submitted to the County Engineer to demonstrate that the allowable street inundation shown in Table 9-3 is not exceeded.
- B.** The minimum grade of gutter sections constructed on existing streets shall be 0.25 percent for vertical curb, and 0.35 percent for all others, with preferable minimum grade of 0.5 percent.
- C.** Standard cross slope on new streets shall be 2.0 percent. A minimum cross slope of 2.0 percent and a maximum of 3.0 percent shall be maintained throughout all areas of cul-de-sacs and 90° elbow intersections (knuckles).
- D.** The minimum cross slope on street widening shall be 1.5 percent and the maximum cross slope shall be 3.0 percent. The cross slope of the widening shall conform to the cross slope of the existing pavement whenever possible. Pavement overlay to street centerline shall be required when this is a feasible method of meeting this standard.
- E.** When two streets intersect, neither street shall have a grade greater than 2.0 percent for a minimum distance of 40 feet measured from the curb line of the intersecting street, except in unusually rough terrain, as determined by the County Engineer. The centerline of the lesser intersecting street shall meet the crown slope at the projected lip of the gutter. Crown slope may be reduced to 1.0 percent within the intersection, if necessary.

For streets with design speeds 40 mph or less, the minimum vertical curve length allowable at the intersection of two grades shall be 100 feet. Vertical curves on streets may be omitted where the algebraic difference in grades does not exceed 2.0 percent. The minimum vertical curve data to be computed and shown on the plans shall consist of the point of intersection elevation, the tangent gradients, the middle ordinate and the length of curve, BVC, EVC stationing, and elevations at ¼ points or every 50 feet whichever is less. Vertical curves for speeds greater than 40 mph shall be in accordance with the Caltrans Highway Design Manual.

- F. The design speed and minimum stopping sight distance over any segment of urban roadway shall comply with Table 4-4, unless the County Engineer specifically approves a lesser design speed.

<b>TABLE 4-4 DESIGN SPEED AND MINIMUM STOPPING SIGHT DISTANCE</b>		
<b><u>Street Type</u></b>	<b><u>Recommended Design Speed</u></b>	<b><u>Minimum Stopping Sight Distance</u></b>
Local Residential	30 MPH	200 feet
Industrial	35 MPH	250 feet
Secondary Collector	35 MPH	250 feet
Primary Collector	40 MPH	300 feet
Arterial (2-lane)	45 MPH	360 feet
Arterial (4-lane)	55 MPH	500 feet
Rural/unposted	65 MPH	660 feet

The minimum design speed for rural and/or unposted roadways shall be 65 MPH or as determined by performance of a recent Speed Survey. Stopping sight distance for other design speeds shall be in accordance with California Department of Transportation Highway Design Manual (Fifth or latest Edition) or as approved by the County Engineer.

Stopping sight distance is measured from the driver's eyes, which are assumed to be 3.5 feet above the pavement surface, to an object 0.5-foot high on the road.

**4-7 PARTIAL STREET**

Partial streets may be permitted by the County Engineer along the boundary of a subdivision or property of the developer where the full right-of-way cannot be dedicated or where the complete street cannot be constructed, but will ultimately be constructed with adjacent development.

The minimum right-of-way width shall be 40 feet or one-half of the proposed right-of-way plus 10 feet, whichever is greater. Lesser right-of-way widths may be allowed when approved by the Board of Supervisors in accordance with State of California Streets and Highways Code Section 906.

Partial streets shall be constructed to a complete geometric and structural section for a minimum paving width, not including gutter, specified by the following:

1. On Local Residential Streets, the pavement width shall be 26 feet.
2. On Collector and Industrial Streets, the pavement shall extend ten feet past centerline for a total of 28 feet.

Curb and gutter width is not included in the above pavement widths.

The intersection pavement edges shall have a minimum radius of 14 feet on the uncompleted side. All other edge of pavement radii shall be 25 feet or greater.

When paving partial construction of an ultimate street development, the edges of the current pavement on the uncompleted side are to be protected by use of 2"x6" pressure preservative treated wood or all-heart redwood headers, or by placing a minimum of 1-foot additional width of aggregate base material beyond the edge of pavement to the grade and depth of the adjacent structural section.

Partial streets shall be terminated with the end of the pavement perpendicular to the street unless otherwise specified below. A 2"x6" pressure preservative treated wood or all-heart redwood header, shall be required at the pavement ending.

Partial streets that terminate adjacent to an intersection or driveway shall be tapered 45 degrees to the street if right-of-way is available.

The end of a partial street that terminates a traveled lane in the direction of travel shall be tapered in accordance with the following equations:

$$\text{Less than 45 mph, } L = WS^2/60$$

$$\text{Greater than or equal to 45 mph, } L = WS$$

Where L = Taper Length along centerline, W = Taper Width reduction or widening (feet) and S = Design Speed (mph).

The design speed used in determining the taper shall be that given in Table 4-4.

The County Engineer may require pavement tapers for the termination of partial streets that are different from the above.

#### **4-8 OFFSET INTERSECTION**

- A. Streets intersecting any residential street from opposite sides shall have their centerlines meet, or the offset between intersections shall be a minimum of 200 feet. Lesser distance may be approved for infill projects.
- B. Streets intersecting any Industrial or Collector Street from opposite sides shall have their centerlines meet, or the offset between intersections shall be a minimum of 250 feet. Lesser distance may be approved for infill projects.
- C. Streets intersecting a 2-lane arterial street from opposite sides shall have their centerlines meet, or the offset between intersections shall be a minimum of 450 feet. Streets intersecting a 4-lane arterial street from opposite sides shall have their centerlines meet, or the offset between intersections shall be a minimum of 650 feet. Pursuant to this section major access driveways

shall be considered as streets with respect to offsets. Lesser distance may be approved for infill projects.

- D. The centerline of intersection streets shall be at right angles to each other, as nearly as practicable.
- E. Infill project applicants shall consult with the County Engineer to determine specific offsets.

#### **4-9 DRIVEWAYS**

Driveway installation shall be in accordance with the Standard Drawings and the following:

- A. The maximum algebraic difference in grade at any grade change within the public right-of-way and a driveway or between a driveway and public roadway shall be ten percent (10%). Driveway slopes and grade changes shall be designed to prevent “bottoming” or scraping of the intended vehicles’ undercarriage on the pavement or concrete.
- B. Driveways (measured from the driveway throat) shall be located at least 7 feet from the side property line. The County Engineer may approve exceptions where warranted based on allowable residential sideyard setbacks, for joint driveways, or in unusual cases. The County Engineer may require joint driveways and a joint use driveway agreement shall be required prior to approval of improvement plans.
- C. On a Class ‘A’ or Class ‘B’ Street, the minimum width for a single-family residential and duplex driveway shall be 10 feet. Maximum single-family residential and duplex driveway width shall be 26 feet for 2 cars and 35 feet for 3 cars at face of curb. Residential driveways shall be placed at least 7 feet from the adjacent property line, as measured from the driveway throat, except on cul-de-sacs. Residential and duplex driveways with plus grades shall have a rise of no more than 8 inches above the back-of-sidewalk grade at a point 7 feet from the back of sidewalk. The driveway width (not including curb transitions) shall occupy not more than a maximum of 40 percent of the lot frontage, except in cul-de-sacs.
- D. On a Class ‘C’ Street, driveways shall conform to Standard Drawing 4-23, or as may be required by the local fire district. Driveways shall be 10 feet wide minimum, and the maximum width shall be 35 feet, exclusive of flares. A culvert shall be provided for any roadside ditch and shall be a minimum of 20’ in length and extend a minimum of 5’ beyond the driveway on both sides. All driveway or culvert improvements within the public right of way are to be privately maintained.
- E. All commercial and multiple family developments shall install heavy driveways as shown on Standard Drawing 4-22 except as otherwise provided in this section. All commercial and industrial driveways shall be a minimum of 24 feet wide, exclusive of flares or aprons. The design of major driveways, which will serve significant traffic volume, as determined by the County Engineer, shall be based on the width, cross section, and geometries of a secondary collector street. Based on anticipated uses, the County Engineer may require greater widths. Driveways on all arterial streets shall have a minimum clear spacing of 200 feet between driveways (see Standard Drawing 4-12). The County Engineer, when warranted by conditions at a particular site, may approve lesser spacing. Exceptions should be obtained as early as possible, prior to submission of improvement plans or development plans.

A center median up to 10 feet wide in the driveway may be approved by the County Engineer for certain driveways. The normal driveway width shall be increased by the median width.



- F.** The standard driveway for industrial developments shall be heavy, 45 feet wide, as shown on Standard Drawing 4-22.
- G.** Where Class “A” or “B” frontage improvements exist, medium driveways as shown on Standard Drawing 4-22 shall be installed for all accesses serving more than four single dwelling units. Where garbage collection vehicles will utilize the driveway to access waste containers, heavy driveways shall be installed, as shown on Standard Drawing 4-22.
- H.** When driveways are abandoned or relocated, the old driveway sections shall be removed and replaced with standard curb and gutter, sidewalk, and landscaping, as appropriate.
- I.** Driveways entering levee roads and driveways entering commercial property on all roads shall have a slope not exceeding 5 percent for a minimum distance of 20 feet, measured from the edge of existing pavement. Driveway slopes and grade changes shall be designed to prevent “bottoming” or scraping of the intended vehicles’ undercarriage or the pavement or concrete. Driveways normally used by vehicles towing trailers shall have special requirements to be determined on an individual basis by the County Engineer.
- J.** Visibility requirements for driveways shall be in accordance with Standard Drawing 4-13. Increased visibility requirements may be required for driveways serving a significant amount of truck traffic.
- K.** Major commercial driveways which will serve significant traffic volume, as determined by the County Engineer, shall be considered as intersecting streets and shall conform to the requirements of Section 4-8 regarding offsets.
- L.** Driveways near major intersections shall be no closer than 100 feet from the present or future intersection curb return (see Standard Drawing 4-12). The County Engineer may grant exceptions for unavoidable, extreme conditions, or on small lots where there is frontage for only one driveway.

#### **4-10 ELBOW INTERSECTION**

Elbows shall be required at right angle intersections in accordance with Standard Drawing 4-10. Only under unavoidable or extreme conditions will an elbow other than  $90^{\circ} \pm 5^{\circ}$  be permitted by the County Engineer.

#### **4-11 CENTERLINE RADII**

The curve data (delta angle, length, tangent, and radius) for all centerline curves as well as for all curves of design features that are not concentric with the center line shall be computed and shown on the plans.

The minimum centerline radius curve for residential streets shall be 200 feet with the exception that streets exceeding 1,000 feet in length and functioning as collectors serving over 99 lots and connecting to arterial streets shall have a minimum radius curve of 500 feet.

The minimum centerline radius curve for collector and industrial streets shall be 500 feet.

The minimum centerline radius curve for arterial (2-lane) streets shall be 800 feet.

The minimum centerline radius curve for arterial (4-lane) streets shall be 2,000 feet.

Special consideration will be given to unusually difficult alignment problems. Any exception to the above minimum centerline radius requirements must be approved by the County Engineer.

Where a centerline radius on a major street that is less than the above requirements is approved by the County Engineer, superelevation may be required.

A minimum tangent length of 200 feet shall be required between reversing curves on residential, collector, and industrial streets. The tangent shall be increased on arterial streets depending on design speeds. A minimum tangent length of 50 feet is required for all local or collector streets approaching an intersection.

**4-12 SIGHT DISTANCE AT INTERSECTIONS**

Streets should not be designed to intersect the inside of curves or at any location where in general, sight distance will be inadequate for drivers to tell if they can safely enter the traffic flow or cross the street. The minimum distance from an intersection to a curve should be the applicable minimum sight distance listed below. The County Engineer may make exceptions for especially difficult design circumstances, only if visibility easements to provide adequate sight distances are dedicated. Minimum intersection design sight distance standards shall comply with Table 4-5.

<b>TABLE 4-5 MINIMUM SIGHT DISTANCE STANDARD</b>		
<b><u>Type of Street Being Entered</u></b>	<b><u>Recommended Design Speed</u></b>	<b><u>Minimum Sight Distance*</u></b>
Residential	30 MPH	330 feet
Industrial	35 MPH	385 feet
<b><u>Type of Street Being Entered</u></b>	<b><u>Recommended Design Speed</u></b>	<b><u>Minimum Sight Distance*</u></b>
Arterial (2-lane)	45 MPH	495 feet
Arterial (4-lane)	55 MPH	605 feet

\*Distance measured from an entering driver's eye position to the position of the closest approaching vehicle's far front corner.

The entering driver's eye position shall be assumed 3 feet to the right of the entering street's centerline, 3.5 feet above the pavement surface, and 11 feet clear of the nearest vehicle lane on the street being entered.

The position of the closest approaching vehicle's far front corner shall be assumed 3 feet from the edge of the nearest approaching vehicle lane and 4.25 feet above the pavement surface for each direction of travel.

Major driveways serving significant traffic volume, as determined by the County Engineer, shall be considered as intersecting streets with regard to intersection sight distance requirements. Minor driveways and private streets should provide the recommended intersection sight distance, and at a minimum, shall provide for stopping sight distance.

All streets and driveways shall conform to Standard Drawing 4-13 for corner visibility requirements, as well as to the requirements herein. Visibility easements shall describe an area to be maintained clear of any and all obstructions to a clear view from the adjacent streets. No sign, hedge, structure, natural growth, fence, or other obstruction to a clear view, higher than 2 1/2 feet above the nearest pavement surface (or traveled area where no pavement exists) shall be installed or maintained or shall be permitted to be installed or maintained within the easement area.

Visibility easements shall be recorded on subdivision maps when required, or by separate document if no map will be recorded.

All visibility easement areas between fences or walls and curbs or sidewalks shall be landscaped with low profile landscaping.

**4-13 INTERSECTION CORNER RADII**

Minimum right-of-way and edge of pavement radii for intersection corner roundings shall comply with Table 4-6 and the Standard Drawings.

<b>TABLE 4-6 MINIMUM INTERSECTION CORNER RADII</b>		
<b><u>Street Type</u></b>	<b><u>Face of Curb Radius</u></b>	<b><u>R/W Radius</u></b>
Residential Streets	25 feet	14 feet or chord
Collector Street	30 feet	Chord
Arterial Streets	35 feet	Chord

All intersection pavement edges on partial streets shall have a minimum radius of 14 feet on the uncompleted side. All other edge of pavement radii shall be 25 feet or greater as determined by turning requirements at the subject location.

**4-14 BUS STOP**

Bus stop turnouts and shelters shall be provided on primary collectors and all arterial streets at all intersections with collector or arterial streets. Bus stop turnouts may also be required at other locations as determined by the County Engineer, in consultation with the Yolo County Transportation District (YCTD). Bus stop turnouts shall be located on the far right hand side of the intersection, unless otherwise required by the County Engineer, and shall be in accordance with Standard Drawing 4-29. Bus stop turnouts, whether mid-block or corner, shall be provided at approximately 1/4 mile intervals along arterial streets.

The Design Engineer shall be responsible for submitting improvement plans to the YCTD and obtaining YCTD’s approval of bus stop locations, shelters, and signage.

**4-15 SIDEWALK RAMP**

Sidewalk ramps shall be constructed at all street intersections and at other locations where required by the County Engineer, in accordance with the American with Disabilities Act and Caltrans Standard Plans A88A and A88B, as appropriate, and Standard Drawing 4-11.

Case “F” is the preferred standard at residential and collector intersections where planter strips are provided

Case “C” with retaining curb is the preferred standard at residential and collector intersections where sidewalks are not separated from the curb and gutter.

Case “A” is the preferred standard at arterial intersections.

At "T" intersections, one ramp shall be constructed in the appropriate position at the nearest property line on the far side of the through street, opposite the ramps at the corner rounding of the intersecting street so that pedestrians are encouraged to cross the through street on the leg unaffected by left-turning traffic from the "T" street.

Detectable warning surfaces shall be wet set into concrete in accordance with the manufacturer's instructions, and shall be fully supported by the underlying concrete. Glue-on or mechanically fastened detectable warning surfaces shall not be allowed.

#### **4-16 CURB AND GUTTER**

Curb and gutter shall be installed adjacent to all developments in accordance with Section 4-4, Table 4-2, and Standard Drawings 4-19 or 4-20, as determined by the County Engineer.

Type “C” Roll Curb and Gutter in accordance with Standard Drawing 4-21 may be used in certain urban in-fill areas to match adjacent curbs and gutters, as approved by the County Engineer. Sidewalk grades at driveways must meet the requirements of the Americans with Disabilities Act.

Temporary hot mix asphalt dikes when permitted by the County Engineer shall be Caltrans Type “A” (6” high) per Caltrans Standard Plan A87B.

#### **4-17 VALLEY GUTTER**

Valley (cross) gutters may be permitted on local residential streets with the specific approval of the County Engineer only when the intersection cannot reasonably be drained to an underground system. See Standard Drawing 4-15. No valley gutter shall be allowed on collector or arterial streets. Valley gutters shall not be allowed on any approach to a signalized intersection.

#### **4-18 SIDEWALK**

Sidewalks shall be provided in accordance with these Standards and the Standard Drawings.

All school, park, and commercial developments shall have minimum 8-foot sidewalks along all frontages, with the exception that 5-foot sidewalks may be used along fenced play areas where no access is provided, as determined by the County Engineer.

Where existing utility poles and other obstructions are situated within the planned sidewalk section, a minimum of 4 feet of clear uninterrupted sidewalk area shall be provided, subject to approval of the County Engineer. Where it is necessary to widen the sidewalk beyond its standard width to attain the 4-foot clearance, the widened area shall extend a minimum of 5 feet beyond each side of the obstruction and a 10-foot taper on each side of the widening shall be required.

Where sidewalks end in fill areas, the fill shall be extended beyond the end of the sidewalk for a minimum distance of 6 feet. As an alternate, a cut-off wall may be constructed at the end of the sidewalk and appropriate connection to the existing public street shall be provided for pedestrians traveling beyond the end of the sidewalk. Sidewalk barricades in accordance with Standard Drawing 4-26 may be required.

With approval by the County Engineer, sidewalks may meander within the right of way behind the curb on arterial streets shown on Standard Drawings 4-6 and 4-7. The cross slope on meandering sidewalks shall be 2%. The distance between the back of the curb and the edge of the sidewalk can vary, but shall not be less than 5 feet nor more than 25 feet, except at transitions. If trees are to be planted in the landscaping strip, the minimum distance between the back of the curb and the edge of the sidewalk shall be 5 feet. The sidewalk shall have no abrupt changes in direction and shall be constructed using only tangents of any length and inside radii of at least 150 feet. The County Engineer may approve other configurations of meandering sidewalks to save existing trees or for special design applications, provided adequate right of way is dedicated.

Sidewalks shall be constructed of Class A, 6-sack concrete and shall be finished and cured in accordance with Caltrans Standard Specifications.

#### **4-19 PEDESTRIAN LANE**

Pedestrian lanes or walkways within a development shall be constructed with a minimum of six inches (6") of Concrete Pavement on six inches (6") of aggregate base compacted to 95% relative compaction for the full width of the easement. Pedestrian lanes likely to be subject to maintenance vehicle traffic shall be reinforced in accordance with Standard Drawing 4-22, medium driveway.

The maximum grade for pedestrian lanes shall be 5.0 percent in the direction of travel, except at any curb ramps. The maximum cross slope shall be 2 percent. The design shall also comply with ADA requirements for an accessible path.

Pedestrian lanes, where situated between lots, shall be fenced with chain link fencing from the street right of way to the back lot line. These fences shall be 6 feet high from the building setback line to the back lot line and 36 inches high from the building setback line to the street right-of-way line.

All pedestrian lanes shall have lighting installed in accordance with Section 5, Street Light Design.

#### **4-20 REPLACING CULVERTS**

The Developer shall replace existing inflow and outflow cross culverts as determined by the County Engineer.

#### **4-21 TRENCHING/BORING IN EXISTING PAVED ROADWAYS**

Directional boring, or other trenchless methods, may be required under streets where, in the opinion of the County Engineer, high peak hour traffic volumes or other unusual conditions exist, or on any street that has been recently constructed, reconstructed, overlaid, or has had any surface treatment (streets considered "new"). Streets shall be considered "new" for a minimum period of ten years following construction, reconstruction, overlay, or any surface treatment. The developer shall provide TV camera inspection of existing sewer and stormdrain facilities following boring operations to demonstrate that boring has not damaged these facilities.

The Developer may be required to coordinate trenching work schedules to avoid cutting new pavement surfaces in instances where maintenance is planned by the Department. When trenching is allowed, trenching and backfill shall be in accordance with Standard Drawing 4-17.

#### **4-22 TESTING OF MATERIALS**

Testing of materials to be utilized in work shall be performed in accordance with the methods of the Laboratory of the State of California, Department of Transportation, or other test methods provided for in these Standards, or accepted by the County Engineer. The Contractor shall schedule operations to facilitate all field testing. The County Engineer shall determine the minimum required tests.

#### **4-23 STREET NAMES**

All roads and streets within a development shall be named in accordance with the Yolo County Master Address Numbering System. No duplication of names already in use or previously proposed shall be permitted. Sound-alike names or names with more than 17 spaces are not acceptable. Street names at intersections shall be continued on both sides of the intersecting streets. Streets that change direction by an angle equal to or greater than 90° shall be known by a different name, except for those roads deemed as meandering by the County Engineer.

Street name signs shall be furnished and erected by the Developer. Street name signs shall conform to these Improvement Standards. Street names and street name sign locations shall appear on plans submitted for approval. Sign details shall be as shown on Standard Drawing 4-28.

Private roads serving more than 4 dwellings and/or businesses shall have street name signs and other signs installed as required by the County Engineer. Street name signs for private roads shall be the same as for public streets (Standard Drawing 4-28), except that the background color of private signs shall be brown. Also, a separate additional sign must be placed on the same post saying "Private Road", which shall be 9 inches wide, 8 inches high, and have 1-3/4 inch high black letters on a white background.

#### **4-24 STREET SIGN LOCATION**

Street sign locations shall conform to the following:

- A.** Two street name sign installations, consisting of double-faced signs conforming to Standard Detail 4-28, are required at each intersection. At a four-way intersection, the installations shall be located on both far right-hand corners of the intersection relative to the street having the greater right-of-way width or relative to the more important street if right-of-way widths are equal.

At a "T" intersection, the first installation shall be located on the near right-hand corner of the terminating street, and the second installation shall be located adjacent to the through street at a point in line with the centerline of the terminating street.

- B.** For highways with frontage roads, the street name sign installations shall be located in the divider strip between the frontage road and the main traveled lanes of the highway. All other requirements shall be as outlined above, except that only one sign shall be required (in the divider strip in line with the centerline of the minor street) when there is no opening in the divider strip for access to the main highway.
- C.** On arterial streets, the street name sign installations are to be located as required by the County Engineer.

- D. Street name signs shall be placed on street light poles where possible, using standard clamp-on "L" brackets.
- E. At signalized intersections, illuminated street name signs shall be placed on all four corners of four-legged intersections and on three corners on "T" intersections.

#### **4-25 TRAFFIC SIGNS**

Regulatory and warning signs to control and advise traffic shall comply with the Manual of Uniform Traffic Control Devices, California Supplement, latest edition. All traffic signs shall be installed by the Developer. At the County's discretion, installation may be performed by County forces, with costs reimbursed by the Developer.

All cul-de-sac and dead-end (stub) streets where the curb at the centerline of the end of the street is not visible from the standard driver's eye position at the entering intersection shall be posted with a standard 24" x 24" code W53A (No Outlet) sign. The bottom of the sign shall be a minimum of 7 feet above the sidewalk. The standard location for the W53A sign is on the right hand side at the tangent point of the corner rounding, 6 inches (minimum) from the back of sidewalk.

#### **4-26 SURVEY MONUMENTS**

Survey monuments shall be installed in accordance with Section 12, Survey Monuments.

All monuments set shall comply with Standard Drawing 12-1 and shall be shown on the recorded Map for the project. Each monument set shall clearly show the registration number of the licensed Civil Engineer or Land Surveyor who set it.

#### **4-27 PERMANENT BARRICADE**

Where improvements are temporarily terminated on a street that may be extended in the future, the improvements shall include a permanent type barricade at the end of the street extending completely across the right-of-way to prohibit access and to serve as a warning to the public. The barricade shall be constructed, erected, painted, and signed in accordance with Standard Drawing 4-26.

Gates may be required where streets stub into public park areas or like areas.

Sidewalk barricades shall be constructed at the end of sidewalks where pedestrians cannot safely continue beyond the end of the sidewalk. Sidewalk barricades shall conform to Standard Drawing 4-26.

#### **4-28 STREET TREES**

In accordance with the County Code, Section 8-1.708, existing trees shall be preserved within any public right of way wherever such trees are suitably located, healthy, and of desirable variety and where approved grading permits the preservation of such trees. Where required, street trees of an approved type shall be planted.

Permission to remove any tree in a public right-of-way or easement shall be obtained from the County Engineer in advance. An Encroachment Permit is required.

All trees removed from within the ultimate right-of-way shall be replaced with trees from the approved street tree list if required per the project conditions of approval, or required by the County Engineer.

Except in planter strips, trees shall not be planted any closer than 10 feet from sidewalks or curbs, unless approved by the County Engineer. If trees are approved closer than 10 feet, then a root control barrier shall be installed adjacent to the sidewalk at all tree plantings. A 20-foot long root control panel shall be centered on the trunk of each tree planted. Root control panels shall be 24" deep minimum and extend to the finish grade of the surrounding sidewalk or curb.

Root control barriers shall be geosynthetic panels commercially manufactured for the purpose of controlling root growth, and approved by the County Engineer. Backfill materials placed adjacent to root control panels shall comply with the compaction requirements of the adjacent road or sidewalk subgrades.

Where trees are located within 20 feet of an intersecting street, the main trunks of such trees shall be trimmed free of branches to a height of 8 feet above the curb grade.

Approved trees for planting in public rights-of-way and public easements are listed in Tables 4-7, 4-8, and 4-9. (Desired trees not listed may be planted with the approval of the County Engineer):

<b>TABLE 4-7 ORNAMENTALS-DECIDUOUS</b>					
<b>COMMON NAME (Scientific Name)</b>	<b>Height</b>	<b>Spread</b>	<b>Growth Rate</b>	<b>Minimum Planter Width</b>	<b>Description</b>
CREPE MYRTLE ( <i>Lagerstromia indica</i> )	30'		Moderate	4'	Vase shaped with attractive trunk and branch pattern. Fall foliage yellow. Crinkled, crepe-like flowers July-Sept.
EASTERN REDBUD "FOREST PANSY" ( <i>Cercis candensia</i> )	25'-35'	25'	Moderate	4'	Round-headed but with horizontally tiered branches in age. Purple foliage and reddish branches.
<b>TABLE 4-8 SHADE TREES - DECIDUOUS</b>					
<b>COMMON NAME (Scientific Name)</b>	<b>Height</b>	<b>Spread</b>	<b>Growth Rate</b>	<b>Minimum Planter Width</b>	<b>Description</b>
CHINESE HACKBERRY ( <i>Celtis sinensis</i> )	40'-60'	40'	Moderate	6'	Rounded tree with grayish bark. Leaves to 4" long, with scallop-toothed edges.
CHINESE PISTACHE ( <i>Pistache chinensis</i> )	35'-60'	50'	Slow	6'	Beautiful fall foliage -- scarlet, crimson, orange, yellow.
COLUMBIA PLANE TREE ( <i>Platanus acerifolia</i> "Bloodgood Strain")	60'	50'	Rapid	8'	Upper trunk and limbs cream-colored. Lobed maple-like leaves 4-10" wide. Brown ball-like seed clusters.
MAIDENHAIR "AUTUMN GOLD" ( <i>Ginko b. "Autumn Gold"</i> )	60'	45'	Slow	6'	Spectacular yellow fall color. Semi-columnar shape.
MAIDENHAIR "SARATOGA" ( <i>Ginko b. "Saratoga"</i> )	60'	45'	Slow	6'	Dense, compact tree with ascending branches and a distinct central leader. Leaves have an unusual "fish tail" shape. Fall color soft golden yellow.
CALIFORNIA SYCAMORE ( <i>Platanus racemosa</i> )			Moderate	8'	



<b>TABLE 4-9 SHADE TREES - EVERGREEN</b>					
<b>COMMON NAME (Scientific Name)</b>	<b>Height</b>	<b>Spread</b>	<b>Growth Rate</b>	<b>Minimum Planter Width</b>	<b>Description</b>
CORK OAK ( <i>Quercus suber</i> )	40'	40'	Moderate	8'	Trunk and principal limbs covered with thick corky bark. 3" toothed leaves shiny dark green above and gray beneath.
HOLLY OAK ( <i>Quercus ilex</i> )	40-70'	40'-70'	Moderate	8'	Spreading umbrella-shaped form at maturity. Upper side of oval leaves dark green underside silvery. Leaves are either toothed or smooth-edged.

**4-29 FENCES**

Fences or walls along public streets shall conform to the setback and height requirements of the County Code. Fences or walls shall not encroach upon visibility easements required by Section 4-12 and Standard Drawing 4-13.

Rear and side yard fences and walls adjacent to freeways, major highways, arterials and collectors shall be constructed of masonry or concrete, in accordance with the requirements of Section 6. Rear and side yard fencing adjacent to other public spaces shall be either masonry, concrete, chainlink with slats, or tubular steel.

Fences and walls may require modification to accommodate street light poles and/or foundations.

**4-30 PRIVATELY OWNED BRIDGE**

A bridge intended for the sole use of the occupants of a multi-family type development or any bridge on a private road shall be designed to withstand an HS-20 load, unless specifically approved by the County Engineer for a lesser loading. Other design features of the bridge, including but not limited to widths, railings, clearances and materials shall be in conformance with Department and State Standards. Developer shall obtain a County Building Permit for private structures. A foundation report prepared by a licensed geotechnical engineer shall be required. Design calculations stamped and signed by the Design Engineer are required, along with any other information required by the Chief Building Official.

**4-31 VEHICLE ACCESS AT STREET TERMINATIONS**

Vehicular access shall not be permitted from the end of a stub street. To obtain vehicular access, the street must be extended through the property or be properly terminated with a standard cul-de-sac bulb.

**4-32 PAVEMENT STRIPING AND MARKINGS**

All pavement striping and markings shall be designed and installed per the California Manual on Uniform Traffic Control Devices, and as follows:

- A. Pavement striping shall be a high-build, ready-mixed, one-component, waterborne acrylic traffic paint conforming to the requirements of State Specification No. PTWB-01R2, or current edition, with an acrylic polymer emulsion such as Dow Fastrack HD-21A, or approved equivalent. The liquid paint shall be applied at no less than 25 mil wet film thickness. Both large gradation and small gradation retroreflective elements shall be embedded into the wet paint. Large gradation retroreflective glass

beads shall be white or yellow 3M Microcrystalline Ceramic elements, or approved equivalent. The small gradation glass beads shall conform to the requirements in AASHTO Designation: M247, Type 1.

- B.** Thermoplastic pavement markings for limit lines and legends shall be “Premark Plus” preformed thermoplastic markings as manufactured by Flint Trading, Inc, or an approved equivalent preformed thermoplastic approved by the County Engineer. The preformed thermoplastic markings shall be 125 mil thick and installed in accordance with the manufacturer’s installation requirements, except that bicycle lane markings shall be 90 mil thick.
- C.** Crosswalk pavement markings materials shall be determined by the County Engineer on a case by case basis, and shall be one of the following:
  - a. Striping as described above.
  - b. Thermoplastic markings as described above.
  - c. “Series 380I ES (white)” or “Series 381I ES (yellow)” pavement marking tape as manufactured by 3M, or an approved equivalent pavement marking tape. Pavement marking tape shall be installed in accordance with the manufacturer’s installation requirements.

<b>Standard Drawings</b>		
<b>Section 4 – Transportation Improvements</b>		
<b>Drawing</b>	<b>Sheets</b>	<b>Description</b>
4-1	1	Local Residential Street
4-2	1	Local Residential-Low Volume Street
4-3	1	Primary Residential Street
4-4	1	Collector Street
4-5	1	Industrial Street
4-6	1	Arterial (2-Lane) Street
4-7	1	Arterial (4-Lane) Street
4-8	1	Rural Street
4-9	1	Residential Cul-de-Sac
4-10	1	90 degree Intersection Elbow
4-11	1	Corner layout for Arterial Intersections
4-12	1	Commercial Frontage and Driveway Regulations
4-13	1	Visibility Requirements at Intersections and Driveways
4-14	1	Class “C” Street Intersection
4-15	1	Concrete Valley Gutter
4-16	1	Pavement Welding Detail
4-17	1	Trench Sections in Improved Areas
4-18	1	Bike Path - Off-street
4-19	1	A2-6 Vertical Curb and Gutter
4-20	1	Low Profile Curb and Gutter
4-21	1	Curbs
4-22	3	Standard Driveway Details
4-23	1	Rural Road – Driveway Detail
4-24	2	Special Commercial Frontage Entrance
4-25	1	Under Sidewalk Drain
4-26	2	Signs and Barricades at Temporary Street Ends

<b>Standard Drawings</b>		
<b>Section 4 – Transportation Improvements</b>		
<b>Drawing</b>	<b>Sheets</b>	<b>Description</b>
4-27	1	Removable Bollard
4-28	3	Street Sign Assembly and Sign Post Details
4-29	3	Bus Turnout and Bus Shelter Design
4-30	1	Temporary Road Closure

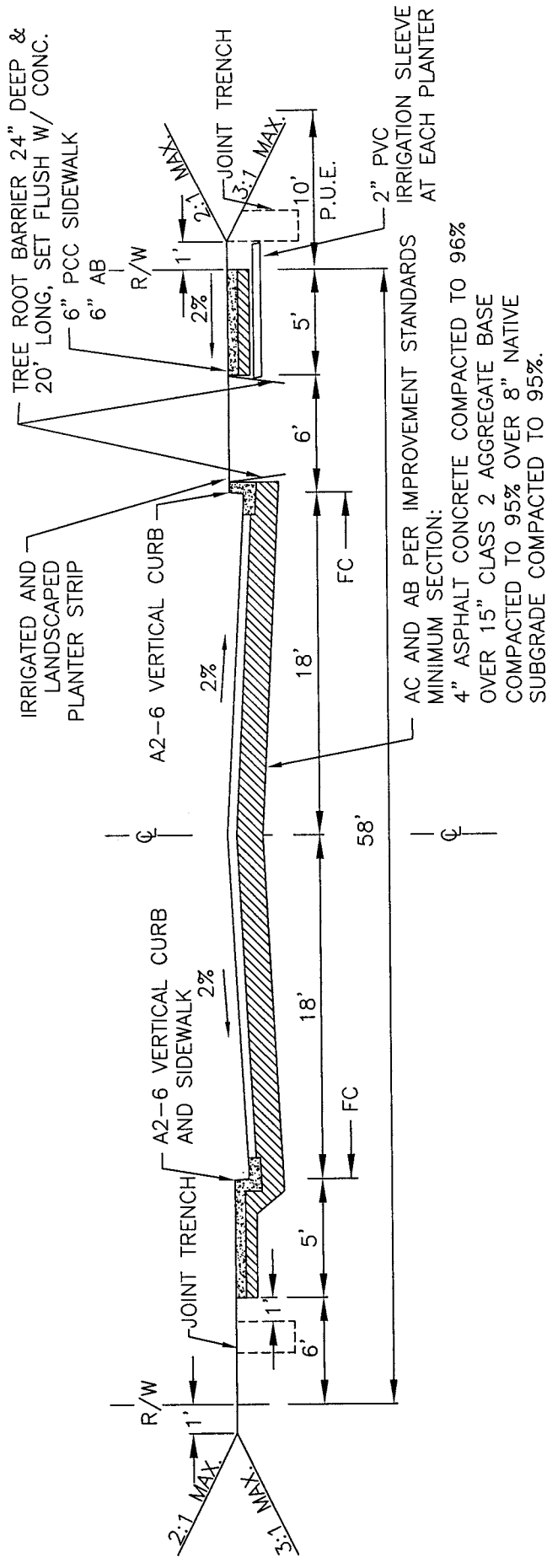

MONOLITHIC CURB, GUTTER AND SIDEWALK OPTION      PLANTER STRIP OPTION

LOCAL RESIDENTIAL

LOCAL RESIDENTIAL: T.I. = 5.0 (MINIMUM)  
 LOCAL RESIDENTIAL CUL-DE-SAC: T.I. = 6.5 (MINIMUM)

**NOTES:**

1. LANDSCAPING WITHIN ROAD RIGHT OF WAY SHALL BE MAINTAINED BY ADJACENT PROPERTY OWNER.
2. REFER TO APPROVED PLANTING LIST FOR TREE SPECIES ALLOWED IN PLANTER STRIPS.
3. JOINT UTILITY TRENCHES CONTAINING DIRECT BURIAL CABLES SHALL BE LOCATED BEHIND THE BACK OF WALK.
4. ADD 10' TO STREET AND RIGHT OF WAY WIDTH WHERE BICYCLE LANES ARE TO BE PROVIDED.
5. LIME OR CEMENT TREATMENT OF THE TOP 12" OF THE SUBGRADE SHALL BE REQUIRED WHERE THE "R" VALUE IS 20 OR LESS.

PLANNING AND PUBLIC WORKS DEPARTMENT	DATE: 08/05/08
LOCAL RESIDENTIAL	SHEET # 1 OF 1
<i>James Kallas</i> COUNTY ENGINEER No. C42401	DRAWING #: 4-1 NOT TO SCALE
	APPROVAL DATE 28 AUG. 08

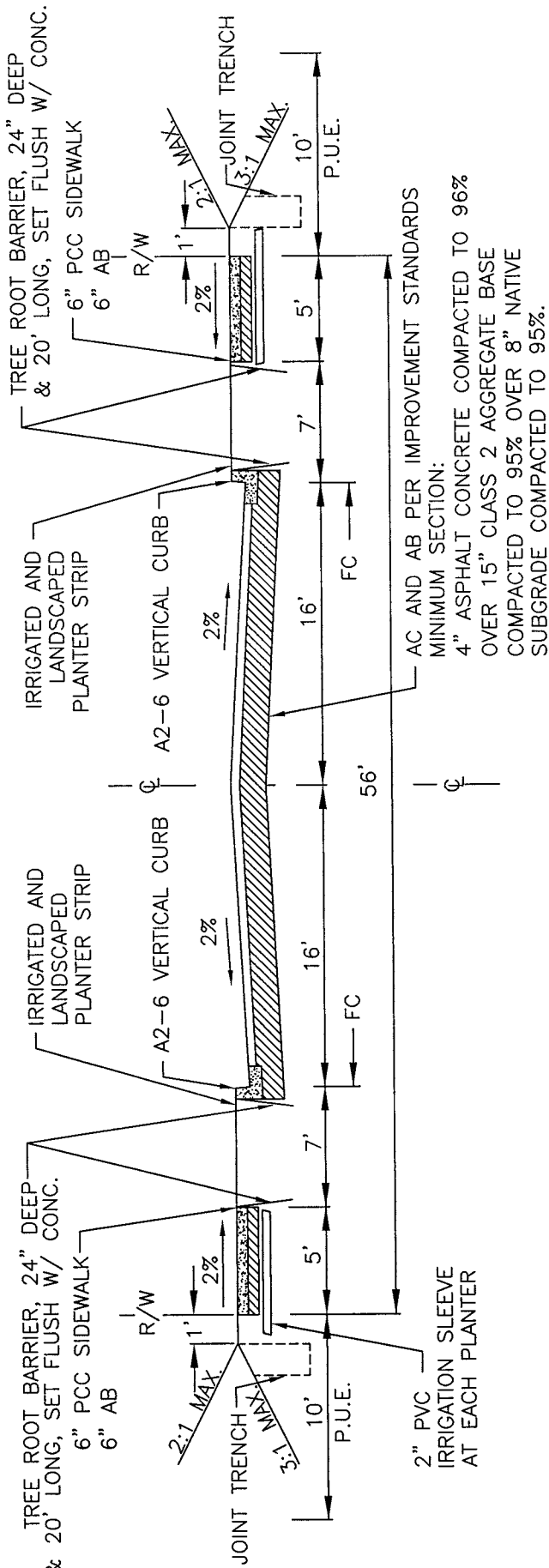

## LOCAL RESIDENTIAL - LOW VOLUME

LOCAL RESIDENTIAL: T.I. = 5.0 (MINIMUM)

LOCAL RESIDENTIAL CUL-DE-SAC: T.I. = 6.5 (MINIMUM)

### NOTES:

- USED ONLY IF SERVING LESS THAN 12 SINGLE FAMILY DWELLING UNITS WITH LOT FRONTAGE < 100'.
- LANDSCAPING WITHIN ROAD RIGHT OF WAY SHALL BE MAINTAINED BY ADJACENT PROPERTY OWNER.
- REFER TO APPROVED PLANTING LIST FOR TREE SPECIES ALLOWED IN PLANTER STRIPS.
- JOINT UTILITY TRENCHES CONTAINING DIRECT BURIAL CABLES SHALL BE LOCATED BEHIND THE BACK OF WALK.
- ADD 10' TO STREET AND RIGHT OF WAY WIDTH WHERE BICYCLE LANES ARE TO BE PROVIDED.
- LIME OR CEMENT TREATMENT OF THE TOP 12" OF THE SUBGRADE SHALL BE REQUIRED WHERE THE "R" VALUE IS 20 OR LESS.

COUNTY OF YOLO  
PLANNING AND PUBLIC WORKS DEPARTMENT

DATE: 08/05/08

LOCAL RESIDENTIAL - LOW VOLUME

SHEET # 1 OF 1

*Carlos Kallas*  
COUNTY ENGINEER No. C42401

DRAWING #: 4-2  
NOT TO SCALE

28 AUG 08  
APPROVAL DATE

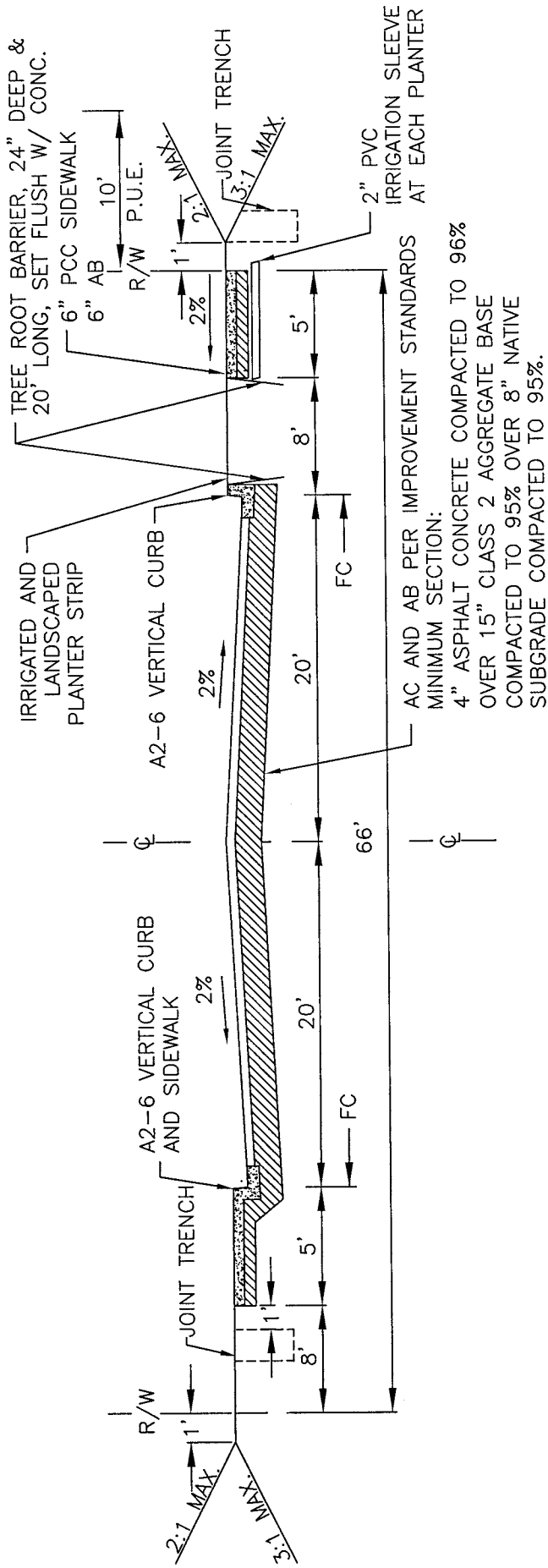

MONOLITHIC CURB, GUTTER AND SIDEWALK OPTION

PLANTER STRIP OPTION

**PRIMARY RESIDENTIAL**

PRIMARY RESIDENTIAL: T.I. = 6.0 (MINIMUM)

NOTES:

1. LANDSCAPING WITHIN ROAD RIGHT OF WAY SHALL BE MAINTAINED BY ADJACENT PROPERTY OWNER.
2. REFER TO APPROVED PLANTING LIST FOR TREE SPECIES ALLOWED IN PLANTER STRIPS.
3. JOINT UTILITY TRENCHES CONTAINING DIRECT BURIAL CABLE SHALL BE LOCATED BEHIND THE BACK OF WALK.
4. ADD 10' TO STREET AND RIGHT OF WAY WIDTH WHERE BICYCLE LANES ARE TO BE PROVIDED.
5. LIME OR CEMENT TREATMENT OF THE TOP 12" OF THE SUBGRADE SHALL BE REQUIRED WHERE THE "R" VALUE IS 20 OR LESS.

COUNTY OF YOLO PLANNING AND PUBLIC WORKS DEPARTMENT	DATE: 08/05/08
PRIMARY RESIDENTIAL	SHEET # 1 OF 1
<i>James Kallas</i> COUNTY ENGINEER No. C42401	DRAWING #: 4-3 NOT TO SCALE
28 Aug. 08	APPROVAL DATE

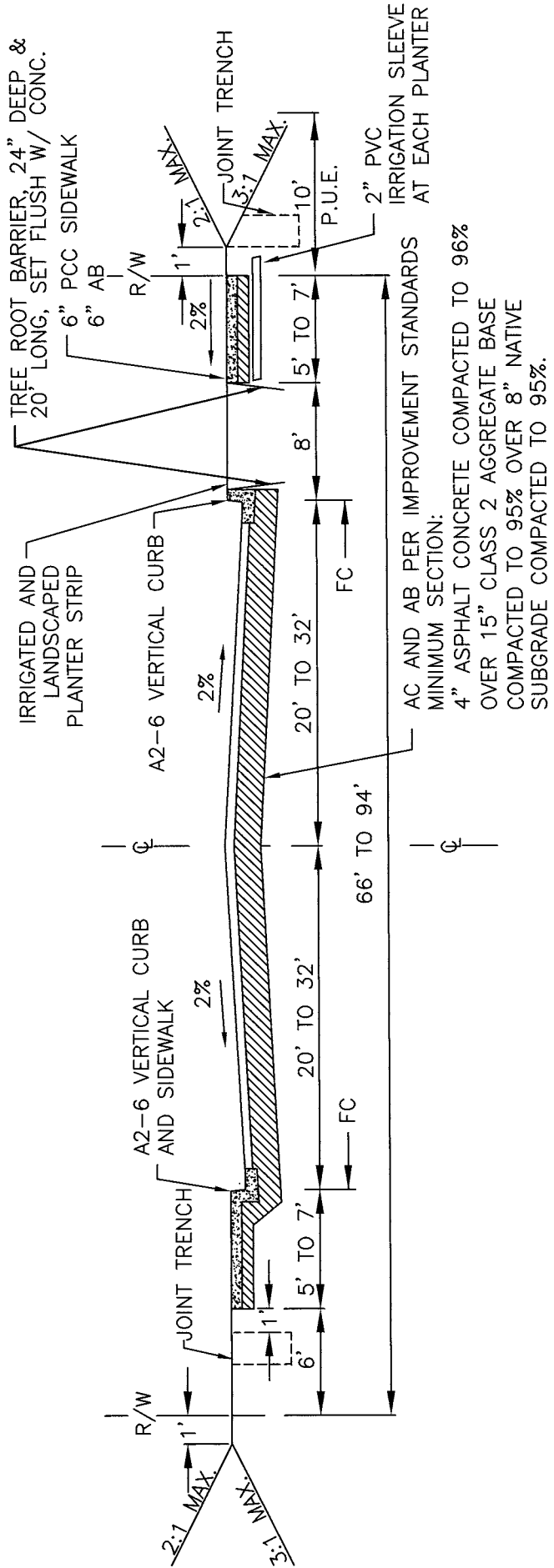

MONOLITHIC CURB, GUTTER AND SIDEWALK OPTION                      PLANTER STRIP OPTION

**COLLECTOR**

T.I. = 7.0 (MINIMUM)

**NOTES:**

1. LANDSCAPING WITHIN ROAD RIGHT OF WAY SHALL BE MAINTAINED BY ADJACENT PROPERTY OWNER.
2. REFER TO APPROVED PLANTING LIST FOR TREE SPECIES ALLOWED IN PLANTER STRIPS.
3. JOINT UTILITY TRENCHES CONTAINING DIRECT BURIAL CABLES SHALL BE LOCATED BEHIND THE BACK OF WALK.
4. ADD 10' TO STREET AND RIGHT OF WAY WIDTH WHERE BICYCLE LANES ARE TO BE PROVIDED.
5. STREET AND SIDEWALK WIDTHS SHALL BE DETERMINED BY THE COUNTY ENGINEER.
6. LIME OR CEMENT TREATMENT OF THE TOP 12" OF THE SUBGRADE SHALL BE REQUIRED WHERE THE "R" VALUE IS 20 OR LESS.

PLANNING AND PUBLIC WORKS DEPARTMENT	COUNTY OF YOLO	DATE: 08/05/08
COLLECTOR		SHEET # 1 OF 1
<i>James Kallas</i> COUNTY ENGINEER No. C42401	28 AUG. 08 APPROVAL DATE	DRAWING #: 4-4 NOT TO SCALE



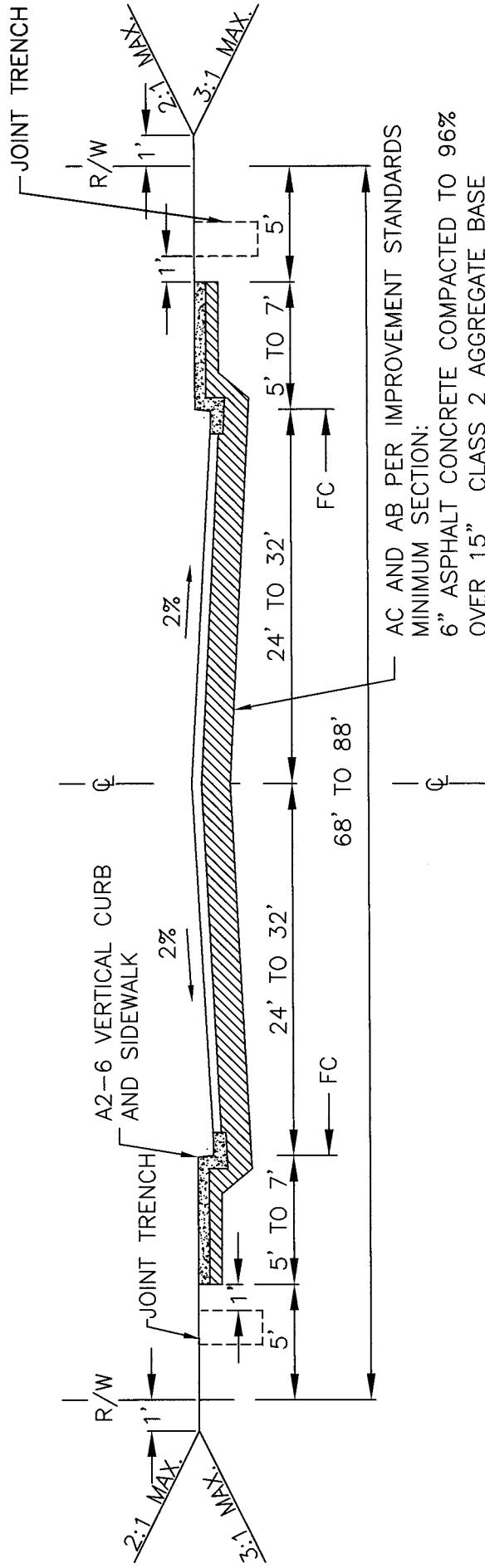

AC AND AB PER IMPROVEMENT STANDARDS  
 MINIMUM SECTION:  
 6" ASPHALT CONCRETE COMPACTED TO 96%  
 OVER 15" CLASS 2 AGGREGATE BASE  
 COMPACTED TO 95% OVER 8" NATIVE  
 SUBGRADE COMPACTED TO 95%

## INDUSTRIAL STREET

INDUSTRIAL: T.I. = 9 (MINIMUM)

**NOTES:**

1. LANDSCAPING WITHIN ROAD RIGHT OF WAY SHALL BE MAINTAINED BY ADJACENT PROPERTY OWNER.
2. JOINT UTILITY TRENCHES CONTAINING DIRECT BURIAL CABLES SHALL BE LOCATED BEHIND THE BACK OF WALK.
3. ADD 10' TO STREET AND RIGHT OF WAY WIDTH WHERE BICYCLE LANES ARE TO BE PROVIDED.
4. STREET AND SIDEWALK WIDTHS SHALL BE DETERMINED BY THE COUNTY ENGINEER.
5. LIME OR CEMENT TREATMENT OF THE TOP 12" OF THE SUBGRADE SHALL BE REQUIRED WHERE THE "R" VALUE IS 20 OR LESS.

COUNTY OF YOLO PLANNING AND PUBLIC WORKS DEPARTMENT	DATE: 08/05/08
INDUSTRIAL STREET	SHEET # 1 OF 1
<i>Panos Kollas</i> COUNTY ENGINEER No. C42401	DRAWING #: <b>4-5</b> NOT TO SCALE
<i>28 Aug 08</i> APPROVAL DATE	

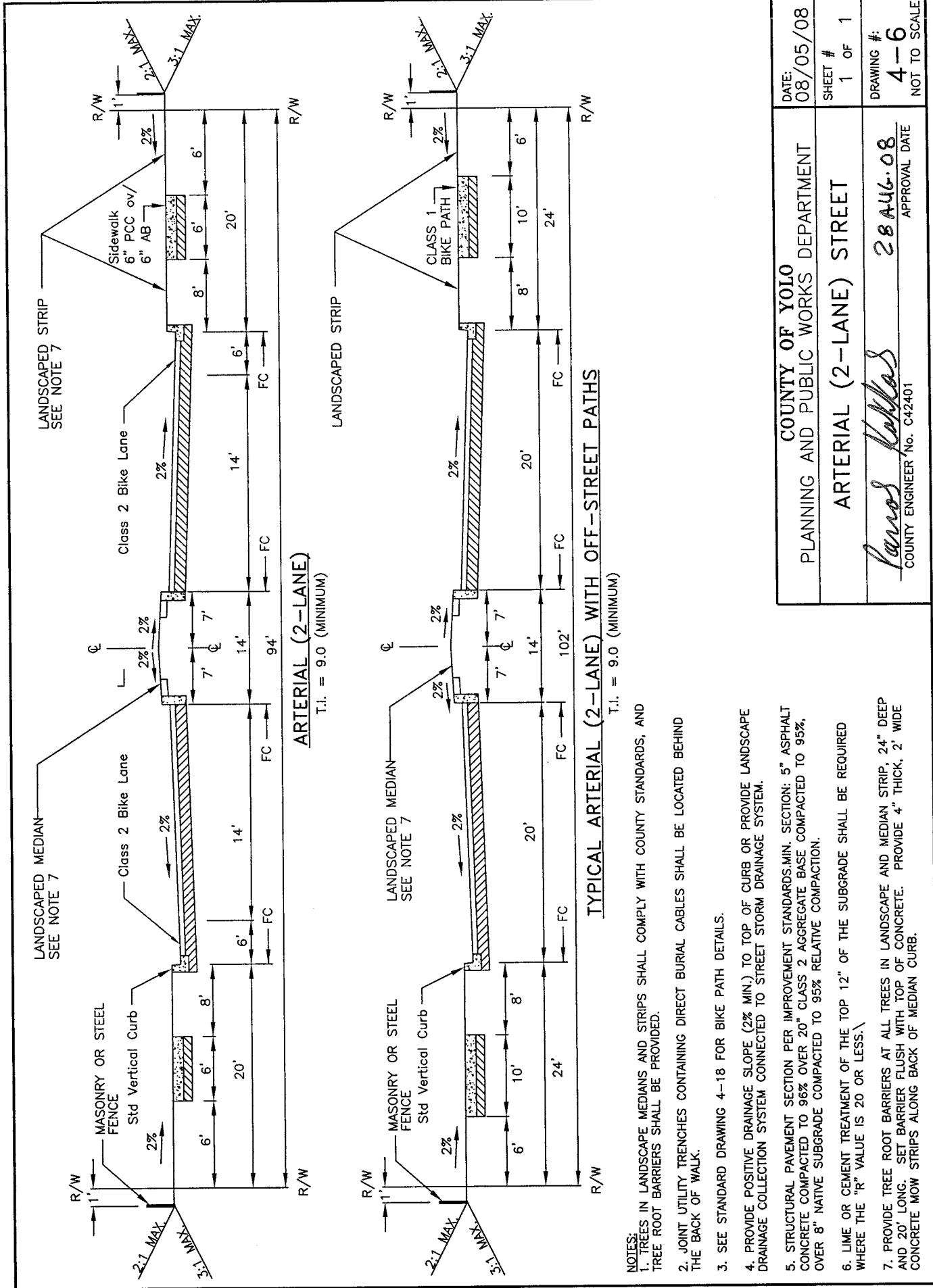

**ARTERIAL (2-LANE)**  
T.I. = 9.0 (MINIMUM)

**TYPICAL ARTERIAL (2-LANE) WITH OFF-STREET PATHS**  
T.I. = 9.0 (MINIMUM)

- NOTES:**
- TREES IN LANDSCAPE MEDIANS AND STRIPS SHALL COMPLY WITH COUNTY STANDARDS, AND TREE ROOT BARRIERS SHALL BE PROVIDED.
  - JOINT UTILITY TRENCHES CONTAINING DIRECT BURIAL CABLES SHALL BE LOCATED BEHIND THE BACK OF WALK.
  - SEE STANDARD DRAWING 4-18 FOR BIKE PATH DETAILS.
  - PROVIDE POSITIVE DRAINAGE SLOPE (2% MIN.) TO TOP OF CURB OR PROVIDE LANDSCAPE DRAINAGE COLLECTION SYSTEM CONNECTED TO STREET STORM DRAINAGE SYSTEM.
  - STRUCTURAL PAVEMENT SECTION PER IMPROVEMENT STANDARDS. MIN. SECTION: 5" ASPHALT CONCRETE COMPACTED TO 96% OVER 20" CLASS 2 AGGREGATE BASE COMPACTED TO 95%, OVER 8" NATIVE SUBGRADE COMPACTED TO 95% RELATIVE COMPACTION.
  - LIME OR CEMENT TREATMENT OF THE TOP 12" OF THE SUBGRADE SHALL BE REQUIRED WHERE THE "R" VALUE IS 20 OR LESS.
  - PROVIDE TREE ROOT BARRIERS AT ALL TREES IN LANDSCAPE AND MEDIAN STRIP, 24" DEEP AND 20' LONG. SET BARRIER FLUSH WITH TOP OF CONCRETE. PROVIDE 4" THICK, 2' WIDE CONCRETE MOW STRIPS ALONG BACK OF MEDIAN CURB.

DATE:	08/05/08
SHEET #	1 OF 1
DRAWING #:	4-6
NOT TO SCALE	
COUNTY OF YOLO PLANNING AND PUBLIC WORKS DEPARTMENT	APPROVAL DATE
ARTERIAL (2-LANE) STREET	<i>Carlos Vallas</i> 28Aug.08
	COUNTY ENGINEER No. C42401

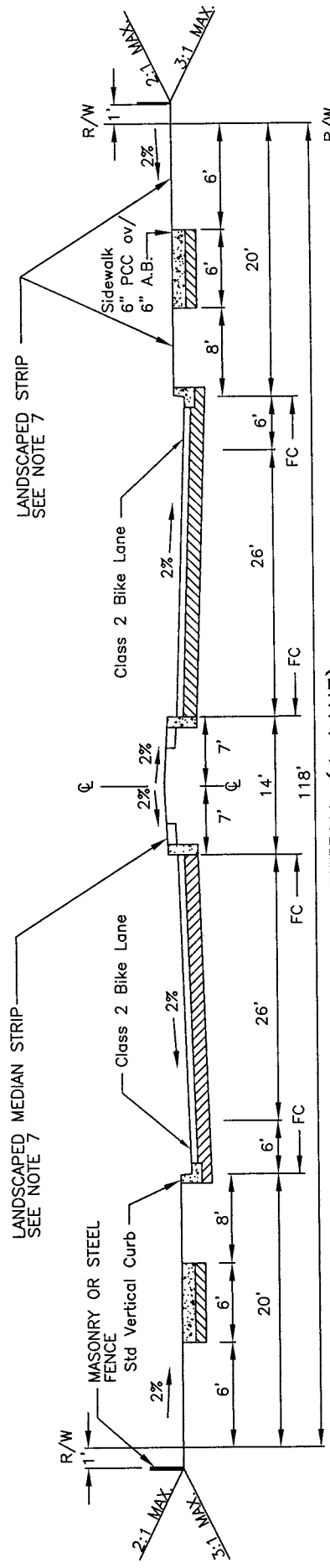

**ARTERIAL (4-LANE)**

T.I. = 10 (MINIMUM)

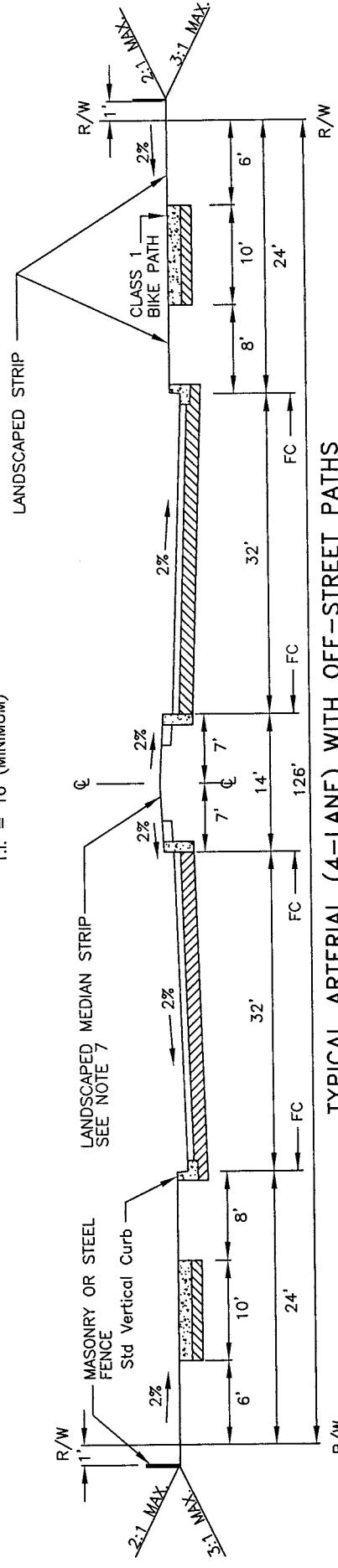

**TYPICAL ARTERIAL (4-LANE) WITH OFF-STREET PATHS**

T.I. = 10 (MINIMUM)

- NOTES:
- TREES IN LANDSCAPE MEDIANS AND STRIPS SHALL COMPLY WITH COUNTY STANDARDS, AND TREE ROOT BARRIERS SHALL BE PROVIDED.
  - JOINT UTILITY TRENCHES CONTAINING DIRECT BURIAL CABLES SHALL BE LOCATED BEHIND THE BACK OF WALK.
  - SEE STANDARD DRAWING 4-18 FOR BIKE PATH DETAILS.
  - PROVIDE POSITIVE DRAINAGE SLOPE (2% MIN.) TO TOP OF CURB OR PROVIDE LANDSCAPE DRAINAGE COLLECTION SYSTEM CONNECTED TO STREET STORM DRAINAGE SYSTEM.
  - STRUCTURAL PAVEMENT SECTION PER IMPROVEMENT STANDARDS. MIN. SECTION: 5" ASPHALT CONCRETE COMPACTED TO 96% OVER 20" CLASS 2 AGGREGATE BASE COMPACTED TO 95%, OVER 8" NATIVE SUBGRADE COMPACTED TO 95% RELATIVE COMPACTION.
  - LIME OR CEMENT TREATMENT OF THE TOP 12" OF THE SUBGRADE SHALL BE REQUIRED WHERE THE "R" VALUE IS 20 OR LESS.
  - PROVIDE TREE ROOT BARRIERS AT ALL TREES IN LANDSCAPE AND MEDIAN STRIP, 24" DEEP AND 20' LONG. SET BARRIER FLUSH WITH TOP OF CONCRETE. PROVIDE 4" THICK, 2' WIDE CONCRETE MOW STRIPS ALONG BACK OF MEDIAN CURB.

DATE:	08/05/08
SHEET #	1 OF 1
DRAWING #:	4-7
NOT TO SCALE	
COUNTY OF YOLO PLANNING AND PUBLIC WORKS DEPARTMENT	
ARTERIAL (4-LANE) STREET	
 COUNTY ENGINEER No. C42401	
APPROVAL DATE 28 AUG. 08	

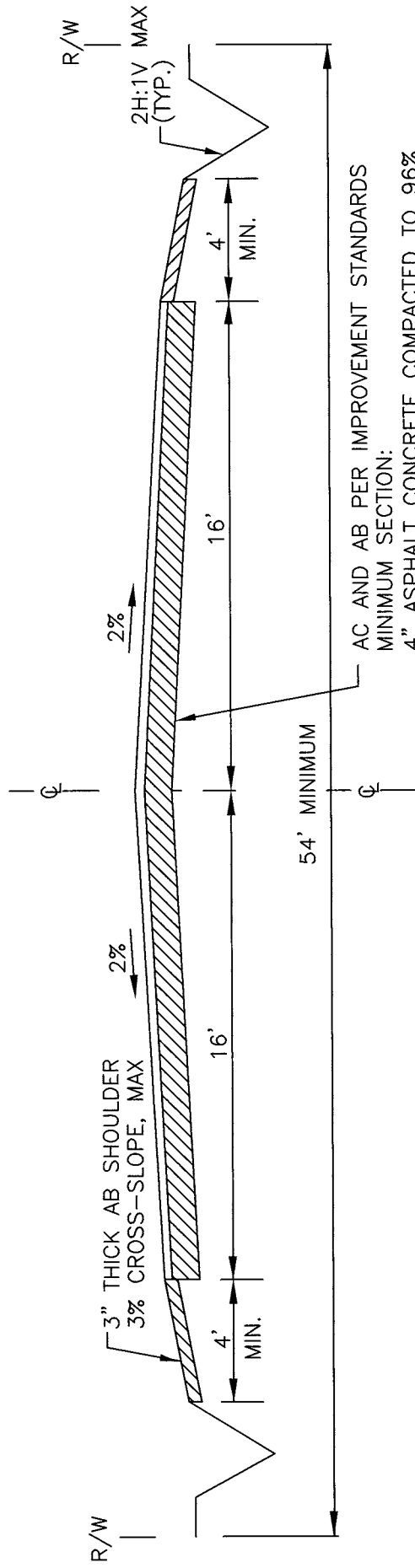

AC AND AB PER IMPROVEMENT STANDARDS  
 MINIMUM SECTION:  
 4" ASPHALT CONCRETE COMPACTED TO 96%  
 OVER 12" CLASS 2 AGGREGATE BASE  
 COMPACTED TO 95% OVER 8" NATIVE  
 SUBGRADE COMPACTED TO 95%.

## RURAL STREET

**NOTES:**

1. MAXIMUM VELOCITY IN EARTHEN ROADSIDE DITCHES IS 4 FEET PER SECOND.
2. EROSION CONTROL DEVICES SHALL BE INSTALLED AS REQUIRED BY COUNTY ENGINEER.
3. ROADSIDE DITCHES SHALL BE SEEDED WITH APPROVED EROSION CONTROL SEED MIX.
4. DRIVEWAY APPROACHES SHALL BE CONSTRUCTED SO AS TO NOT IMPEDE DRAINAGE AWAY FROM THE ROAD.
5. MINIMUM RESIDENTIAL AND COMMERCIAL DRIVEWAY APPROACH SHALL CONSIST OF 3" ASPHALT CONCRETE OVER 8" CLASS 2 AGGREGATE BASE.
6. VEHICLE LANE WIDTH SHALL BE 11' MINIMUM. STRIPED IN ACCORDANCE WITH CALTRANS STANDARDS.

COUNTY OF YOLO PLANNING AND PUBLIC WORKS DEPARTMENT	DATE: 08/05/08
RURAL STREET	SHEET # 1 OF 1
<i>Ronald Kokkas</i> COUNTY ENGINEER No. C42401	DRAWING #: <b>4-8</b> NOT TO SCALE
<i>28 AUG 08</i> APPROVAL DATE	

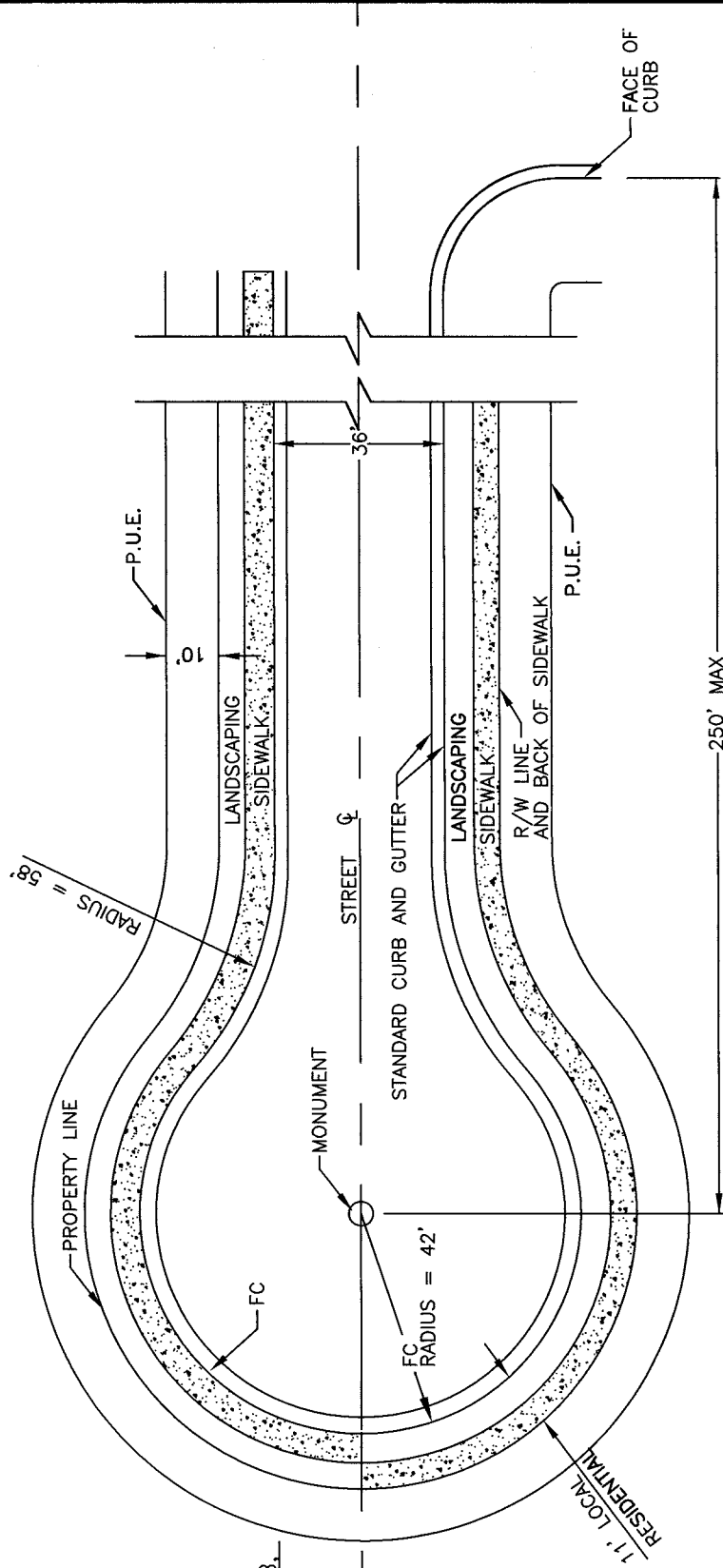

MONOLITHIC CURB,  
GUTTER AND  
SIDEWALK OPTION

PLANTER STRIP  
OPTION

T.I.=6.5 (MINIMUM)

**NOTES:**

1. LANDSCAPING WITHIN ROAD RIGHT OF WAY SHALL BE MAINTAINED BY ADJACENT PROPERTY OWNER.
2. REFER TO APPROVED PLANTING LIST FOR TREE SPECIES ALLOWED IN PLANTER STRIPS.
3. W53 ("NOT A THROUGH STREET") SIGN MAY BE REQUIRED.
4. INCREASED STRUCTURAL SECTION REQUIRED IN CUL DE SAC.
5. FACE OF CURB RADIUS IS 50' FOR INDUSTRIAL STREETS.
6. INDUSTRIAL AND COMMERCIAL CUL-DE-SACS REVIEWED ON CASE BY CASE BASIS CONSIDERING TRUCK TRAFFIC.

COUNTY OF YOLO PLANNING AND PUBLIC WORKS DEPARTMENT	DATE: 08/05/08
RESIDENTIAL CUL DE SAC	SHEET # 1 OF 1
<i>James Koblas</i> COUNTY ENGINEER No. C42401	DRAWING #: 4-9 NOT TO SCALE
28 AUG. 08 APPROVAL DATE	



LOCAL RESIDENTIAL OR  
PRIMARY RESIDENTIAL

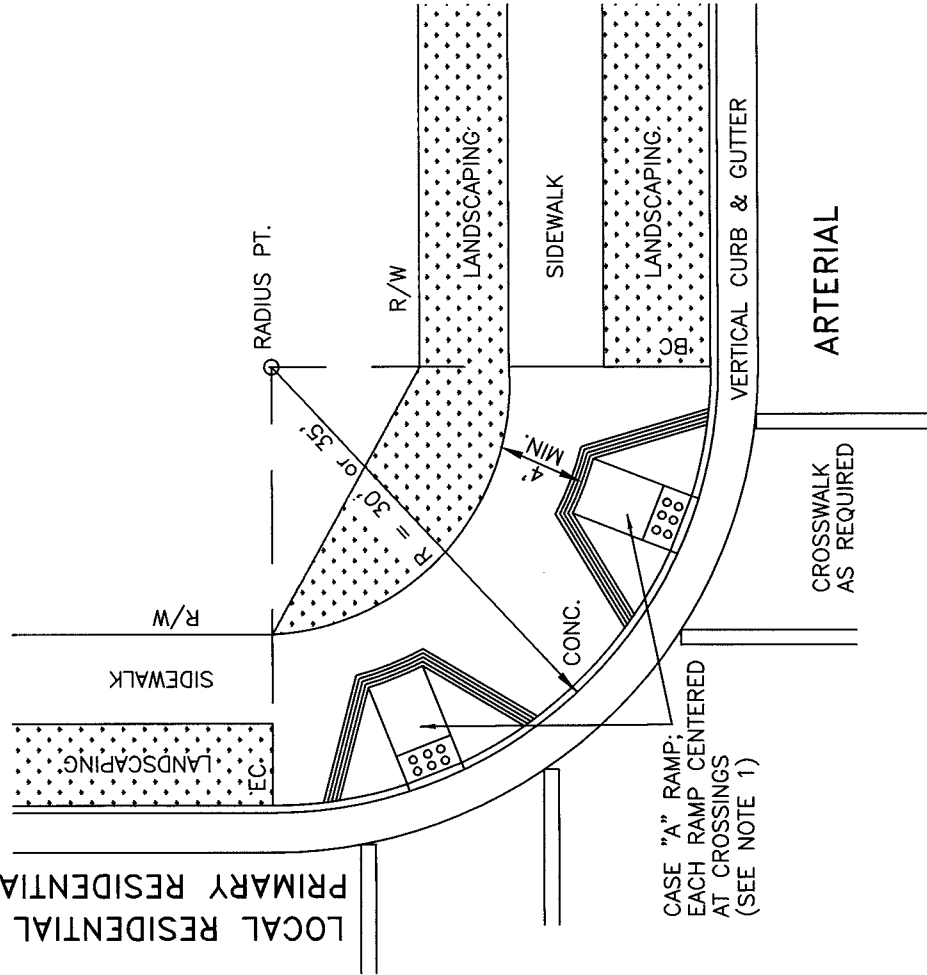

CASE "A" RAMP;  
EACH RAMP CENTERED  
AT CROSSINGS  
(SEE NOTE 1)

CROSSWALK  
AS REQUIRED

ARTERIAL

LOCAL RESIDENTIAL OR  
PRIMARY RESIDENTIAL

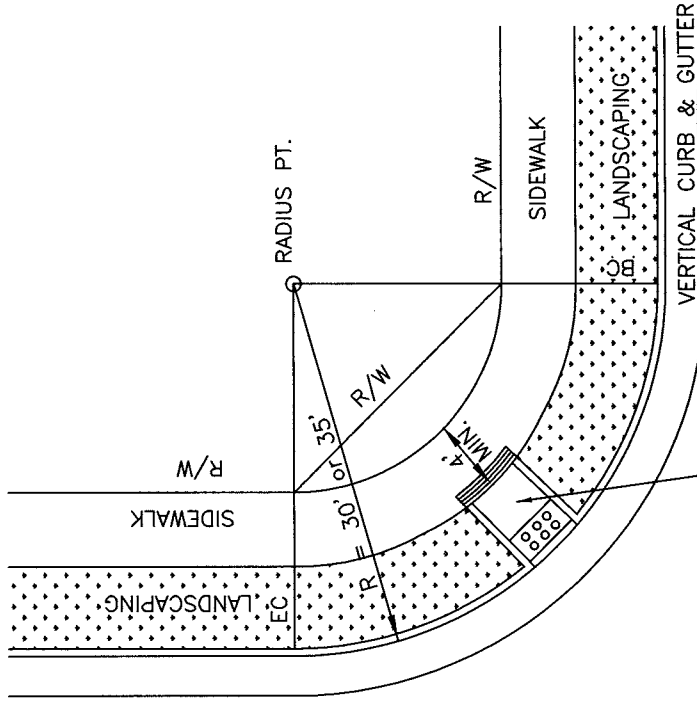

CASE "F" RAMP;  
CENTERED IN RETURN, DEPRESS SIDEWALK AS REQ'D  
(SEE NOTE 2)

ARTERIAL

**NOTES:**

1. FOR ADA RAMP DESIGNATIONS REFER TO CALTRANS STANDARD PLANS "CURB RAMP DETAILS" PLAN A88A, LATEST EDITION.
2. USE CASE "C" WITH RETAINING CURB WHERE SIDEWALK IS INTEGRAL WITH CURB AND GUTTER.

COUNTY OF YOLO PLANNING AND PUBLIC WORKS DEPARTMENT	DATE: 08/05/08
CORNER LAYOUT FOR ARTERIAL INTERSECTIONS	SHEET # 1 OF 1
<i>Paros Kollas</i> COUNTY ENGINEER No. C42401	DRAWING #: 4-11 NOT TO SCALE
20 AUG. 08 APPROVAL DATE	

FRONTAGE (EACH STREET)	MAXIMUM NUMBER OF DRIVEWAYS
UNDER 200'	ONE STANDARD DRIVEWAY
OVER 200'	TWO DRIVEWAYS OR MEET APPROVAL OF THE COUNTY ENGINEER.

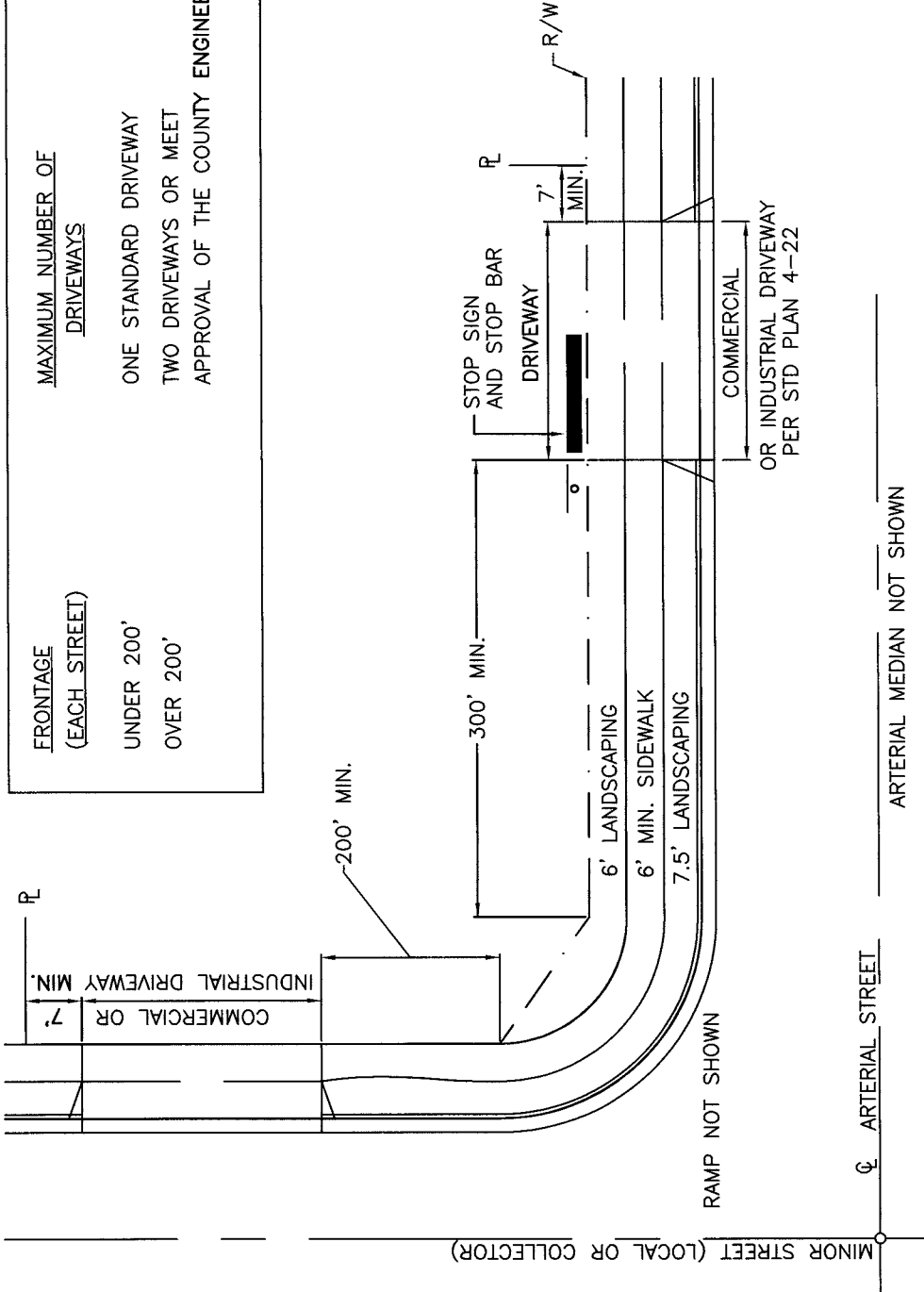

**NOTE:**

- DRIVEWAYS ON ARTERIAL STREETS SHALL HAVE A MINIMUM CLEAR SPACING OF 150 FEET. LESSER SPACING MAY BE APPROVED BY THE COUNTY ENGINEER FOR UNAVOIDABLE, EXTREME CONDITIONS, OR ON SMALL LOTS WHERE A MINIMUM OF ONE DRIVEWAY PER STREET FRONTAGE WILL BE PROVIDED.

COUNTY OF YOLO PLANNING AND PUBLIC WORKS DEPARTMENT	DATE: 08/05/08
COMMERCIAL FRONTAGE AND DRIVEWAY REGULATIONS	SHEET # 1 OF 1
<i>Parsons</i> COUNTY ENGINEER No. C42401	DRAWING #: 4-12 NOT TO SCALE
28 AUG 08 APPROVAL DATE	



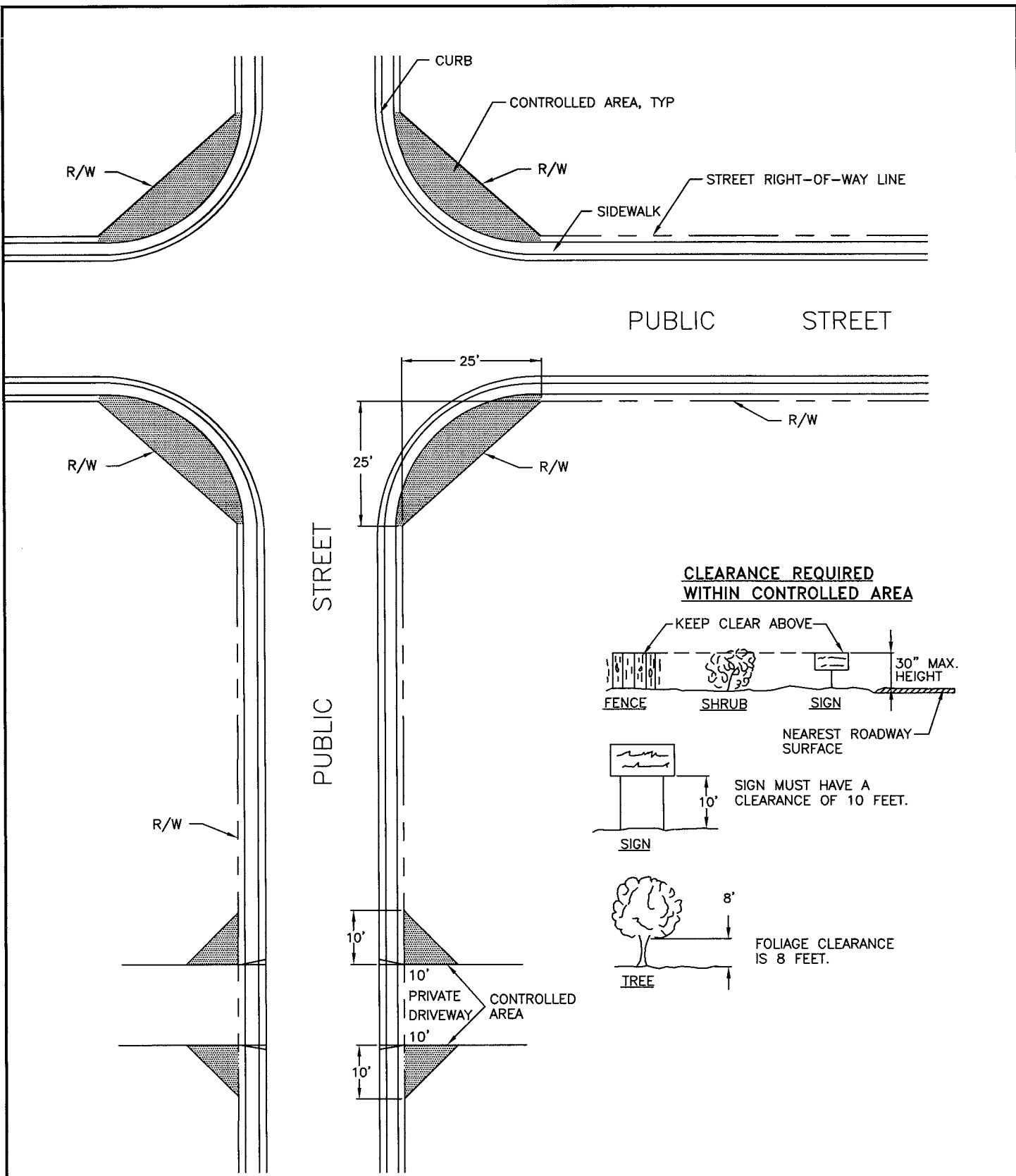

<b>COUNTY OF YOLO</b> PLANNING AND PUBLIC WORKS DEPARTMENT		DATE: 08/05/08
<b>VISIBILITY REQUIREMENTS AT INTERSECTIONS AND DRIVEWAYS</b>		SHEET # 1 OF 1
<i>Paros Kallas</i> COUNTY ENGINEER No. C42401		DRAWING #: <b>4-13</b> NOT TO SCALE
28 AUG. 08 APPROVAL DATE		

EXISTING EDGE OF PAVED SHOULDER

EDGE OF TRAVELLED WAY

ARTERIAL OR COLLECTOR

☉ OR LANE LINE

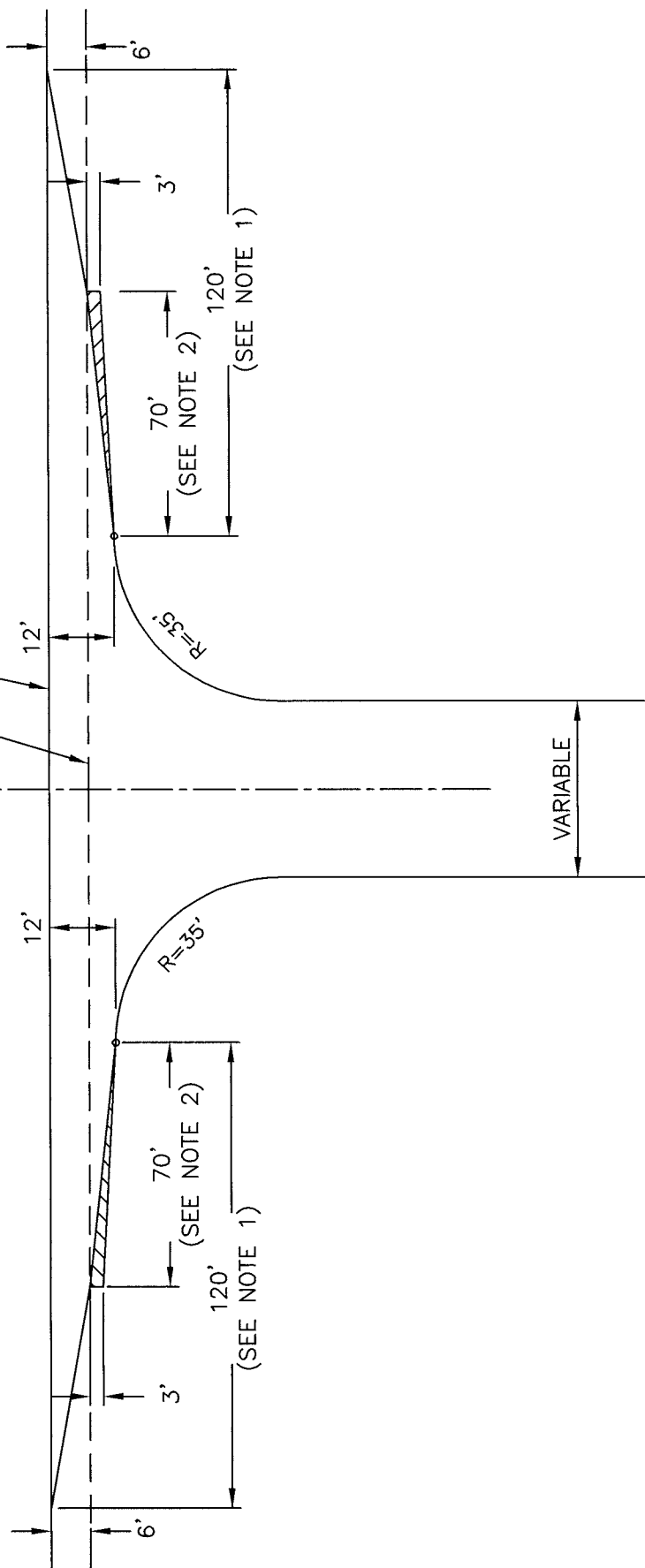

**NOTES:**

1. USE 120' PAVEMENT TAPER SECTION WHEN MAJOR STREET SHOULDER IS UNPAVED OR SEAL COATED.
2. USE 70' PAVEMENT TAPER SECTION WHEN MAJOR STREET SHOULDER IS FULLY PAVED.
3. FULL ROADBED STRUCTURAL SECTION TO BE PLACED IN ACCORDANCE WITH COUNTY STANDARDS FOR AREA TO BE PAVED.
4. PAVEMENT TAPER SECTION MAY BE DELETED ON LOCAL STREETS.

COUNTY OF YOLO PLANNING AND PUBLIC WORKS DEPARTMENT	DATE: 08/05/08
CLASS "C" STREET INTERSECTION	SHEET # 1 of 1
<i>Pauls Volker</i> COUNTY ENGINEER No. C42401	DRAWING #: 4-14 NOT TO SCALE
28 AUG. 08 APPROVAL DATE	

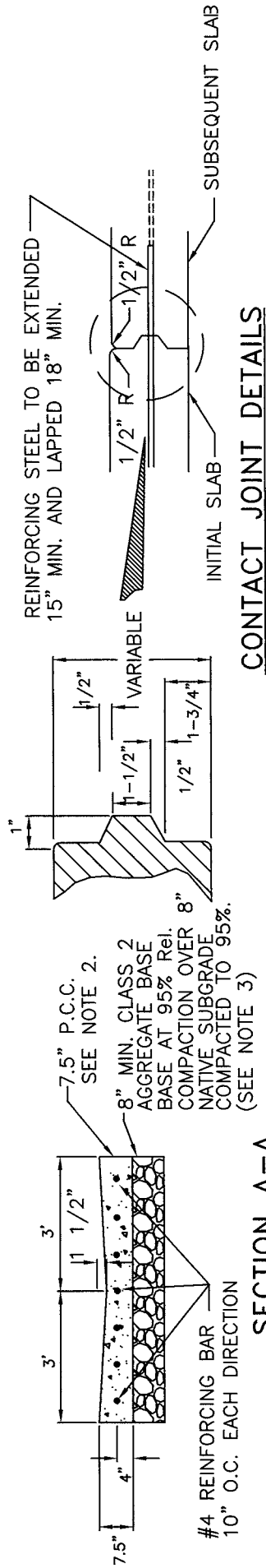

**CONTACT JOINT DETAILS**

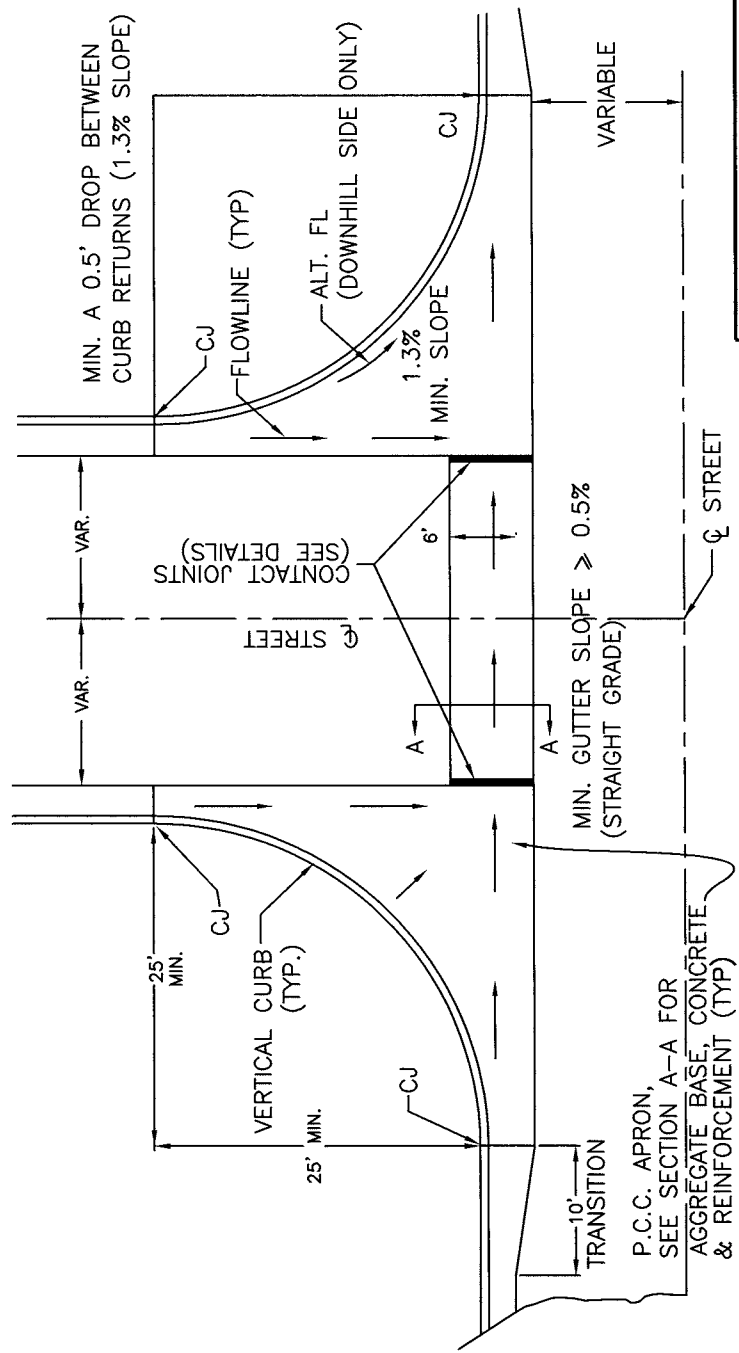

**NOTES:**

1. CONCRETE VALLEY GUTTERS ALLOWED ONLY IN RETROFIT AND SPECIAL SITUATIONS, WITH THE APPROVAL OF THE COUNTY ENGINEER.
2. ALL CONCRETE SHALL BE CLASS A, 6-SACK CONCRETE, WITH LIGHT BROOM FINISH.
3. 8" MIN. CLASS 2 AB TO BE PLACED UNDER CONCRETE PAVEMENT. AB SHALL EXTEND TO SUBGRADE OF DEEPEST ADJACENT STREET SECTION.
4. SIDEWALK AND RAMPS NOT SHOWN.
5. REINFORCING BAR SHALL BE SUPPORTED ON DOBIES.
6. SEE "CONTACT JOINT DETAILS" FOR CONSTRUCTION JOINTS IN PAVEMENT. OTHER CONSTRUCTION JOINTS SHALL BE MADE WITH 3' LONG, #4 BARS AT 12" O.C. PROVIDE TOOLED CRACK CONTROL JOINTS AT APPROXIMATELY 5' SPACING IN AN AESTHETICALLY PLEASING PATTERN.

COUNTY OF YOLO PLANNING AND PUBLIC WORKS DEPARTMENT		DATE: 08/05/08
CONCRETE VALLEY GUTTER		SHEET # 1 OF 1
<i>Pamela Kollas</i> COUNTY ENGINEER No. C42401		DRAWING #: 4-15 NOT TO SCALE
APPROVAL DATE 28 AUG 08		

1 1/2" DEEP GRINDING AND PAVING. 12" MINIMUM.  
 FOR NEW PAVEMENT (WITHIN 5 YEARS OF RESURFACING)  
 GRIND TO OPPOSITE LIP OF GUTTER, OR AS REQUIRED  
 BY COUNTY ENGINEER.

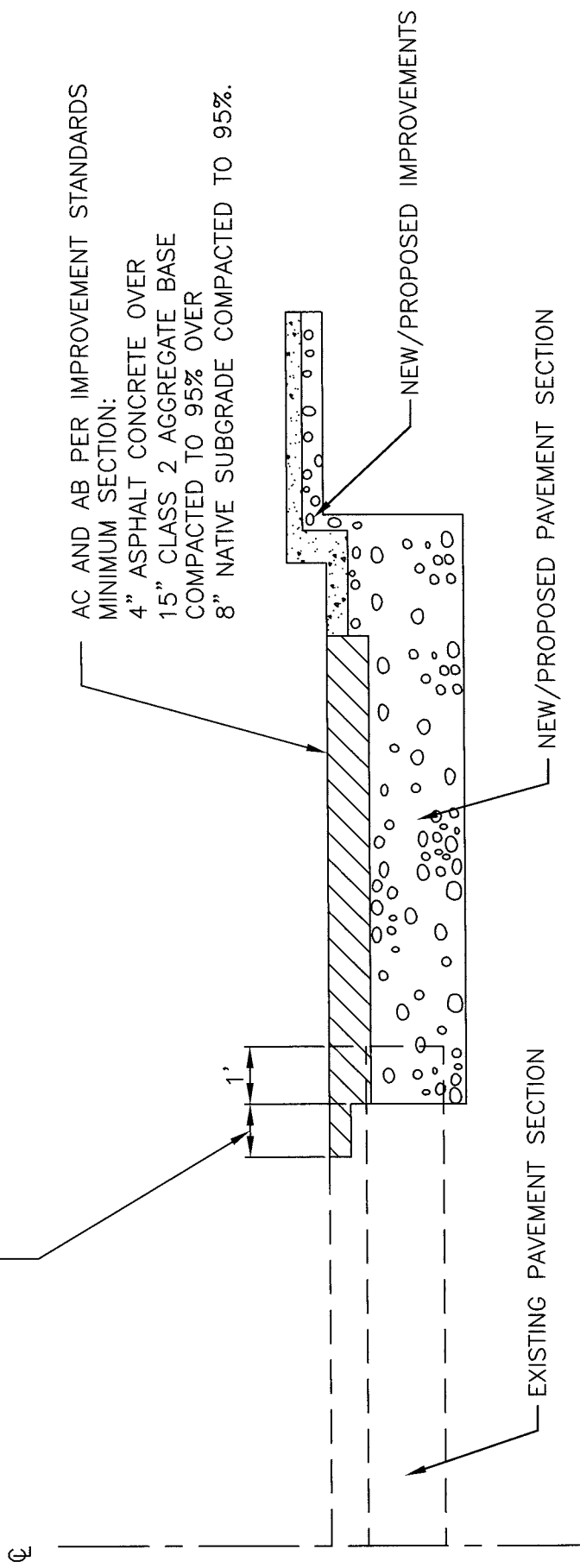

COUNTY OF YOLO PLANNING AND PUBLIC WORKS DEPARTMENT	DATE: 08/05/08
PAVEMENT WELDING DETAIL	SHEET # 1 OF 1
<i>Pamela Kollas</i> COUNTY ENGINEER No. C42401	DRAWING #: 4-16 NOT TO SCALE
28 AUG. 08 APPROVAL DATE	

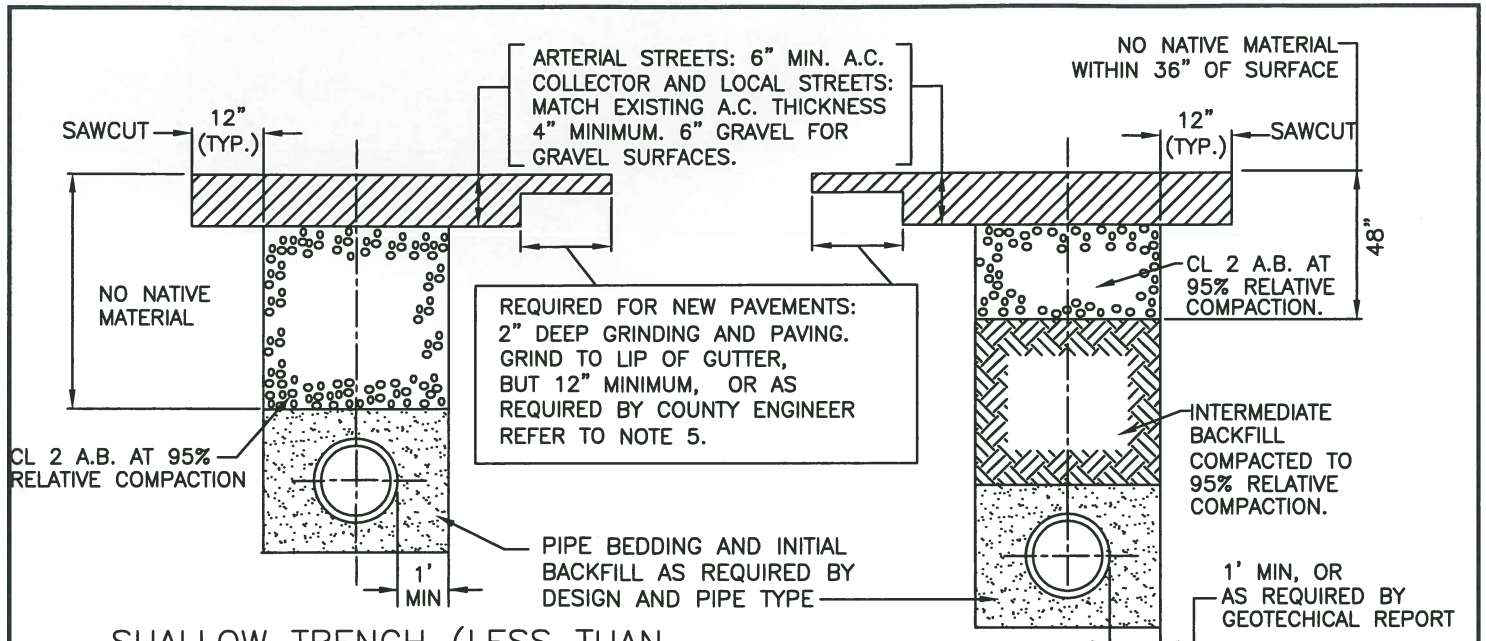

SHALLOW TRENCH (LESS THAN 4 FEET COVER) IN EXISTING PAVEMENT OR GRAVEL SURFACES

DEEP TRENCH (4 FEET OR MORE COVER) IN EXISTING PAVED AREAS AND OTHER TRENCHING

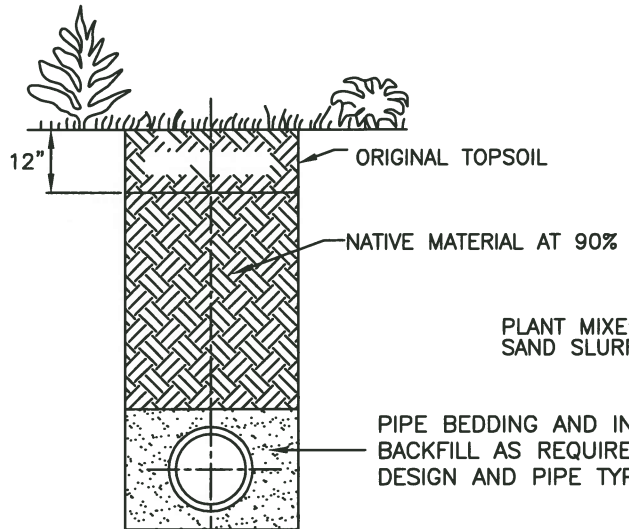

HORTICULTURE LAWN, OR CULTIVATED AREAS (MORE THAN 6' FROM PAVEMENTS OR CONCRETE FLATWORK).

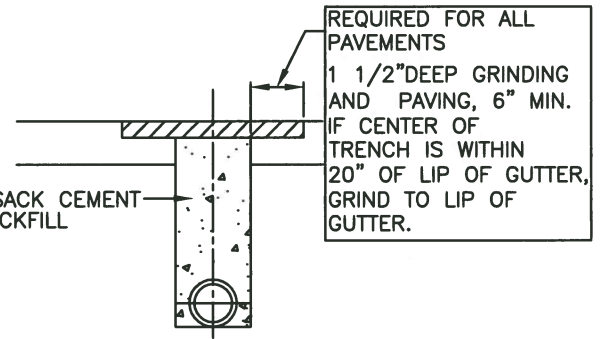

EARTH SAW TRENCH SECTION

**NOTES:**

1. TACK COAT ALL EXPOSED EDGES OF ASPHALT CONCRETE PATCH.
2. TRENCHING WITHIN 6' OF ASPHALT CONCRETE OR CONCRETE SURFACES SHALL BE CONSIDERED WITHIN EXISTING PAVEMENT FOR THE PURPOSE OF DETERMINING BACKFILL COMPACTION.
3. FINAL COMPACTION TESTING SHALL BE PROVIDED BY CONTRACTOR AND DEMONSTRATE COMPLIANCE WITH SPECIFIED COMPACTION.
4. PLANT MIXED 2-SACK CEMENT SAND SLURRY (SLURRY) MAY BE REQUIRED FOR ALL BACKFILL AT THE COUNTY ENGINEER'S DISCRETION. SLURRY SHALL HAVE 10" TO 11" SLUMP, AND FLY ASH MAY BE ADDED TO THE MIX.
5. SLURRY MAY BE SUBSTITUTED FOR ANY BACKFILL.
6. IF EDGE OF "T" CUT FALLS 24" OR LESS FROM LIP OF GUTTER OR FROM THE EDGE OF AN EXISTING TRENCH PATCH, REMOVE AND REPLACE THE AC TO THE EDGE OF THE EXISTING PATCH, OR THE LIP OF GUTTER.

<b>COUNTY OF YOLO</b> PLANNING AND PUBLIC WORKS DEPARTMENT		DATE: 07/03/18
<b>TRENCH SECTIONS</b> <b>IN IMPROVED AREAS</b>		SHEET # 1 OF 1
 COUNTY ENGINEER No. C42401		3 JULY 2018 APPROVAL DATE
		DRAWING #: <b>4-17</b> NOT TO SCALE

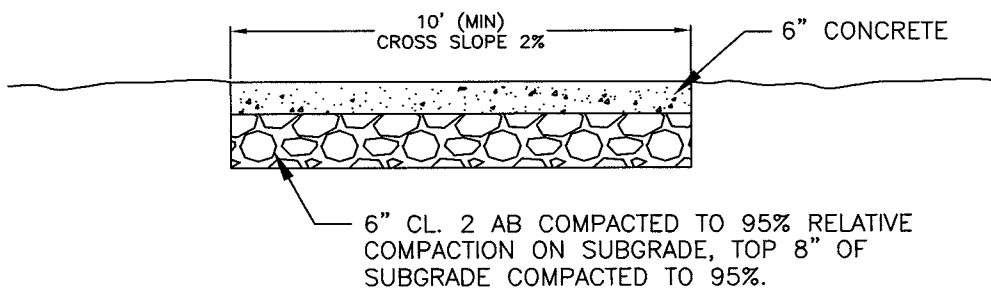

CROSS SECTION

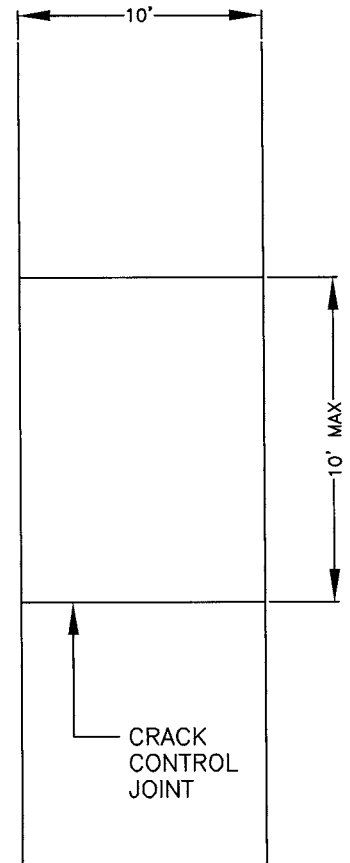

PLAN VIEW

**NOTES:**

1. CONCRETE SHALL BE 6-SACK CLASS "A".
2. PROVIDE TRANSVERSE CRACK CONTROL JOINTS, 1" DEEP AT 10' SPACING, EXPANSION JOINTS AT 60' SPACING.
3. SURFACE FINISH SHALL BE TRANSVERSE MEDIUM BROOM FINISH.
4. APPLY CURING COMPOUND PER THE CALTRANS STANDARD SPECIFICATIONS.
5. THE PAVEMENT SECTION SHOWN IS THE MINIMUM REQUIRED. PAVEMENT STRUCTURAL SECTION SHALL BE BASED ON GEOTECHNICAL EVALUATION OF SOIL CONDITIONS, AND TI=5 TO ALLOW FOR MAINTENANCE VEHICLE LOADS.
6. REFER TO CALTRANS HIGHWAY DESIGN MANUAL FOR ADDITIONAL BIKE PATH DESIGN REQUIREMENTS.

<b>COUNTY OF YOLO</b>		DATE:
PLANNING AND PUBLIC WORKS DEPARTMENT		08/05/08
<b>BIKE PATH - OFFSTREET</b>		SHEET #
		1 OF 1
 COUNTY ENGINEER No. C42401	28 AUG. 08 APPROVAL DATE	DRAWING #:

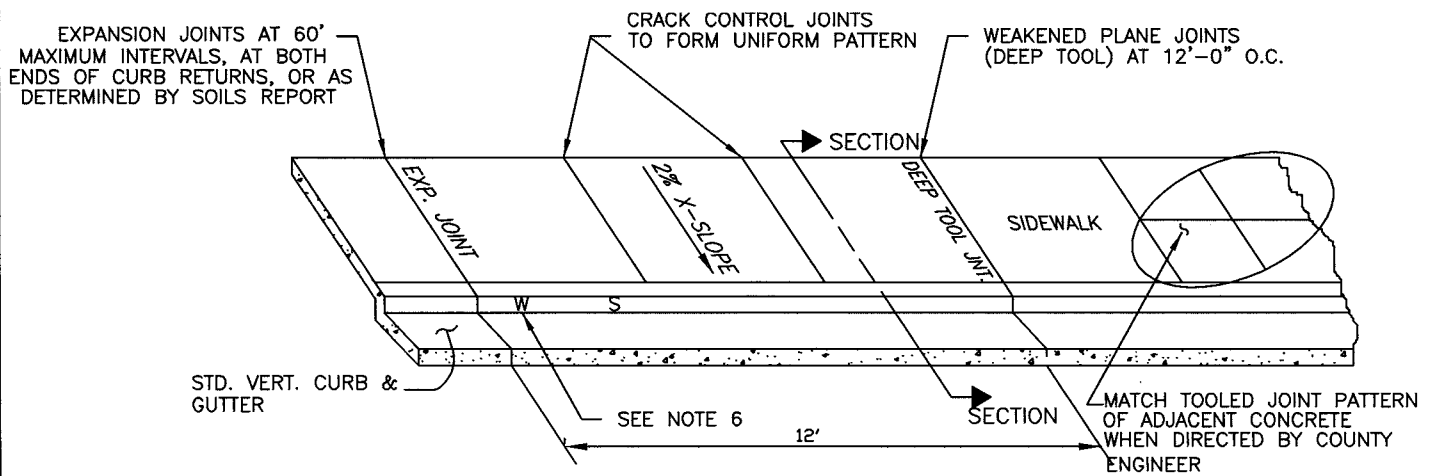

**PERSPECTIVE**

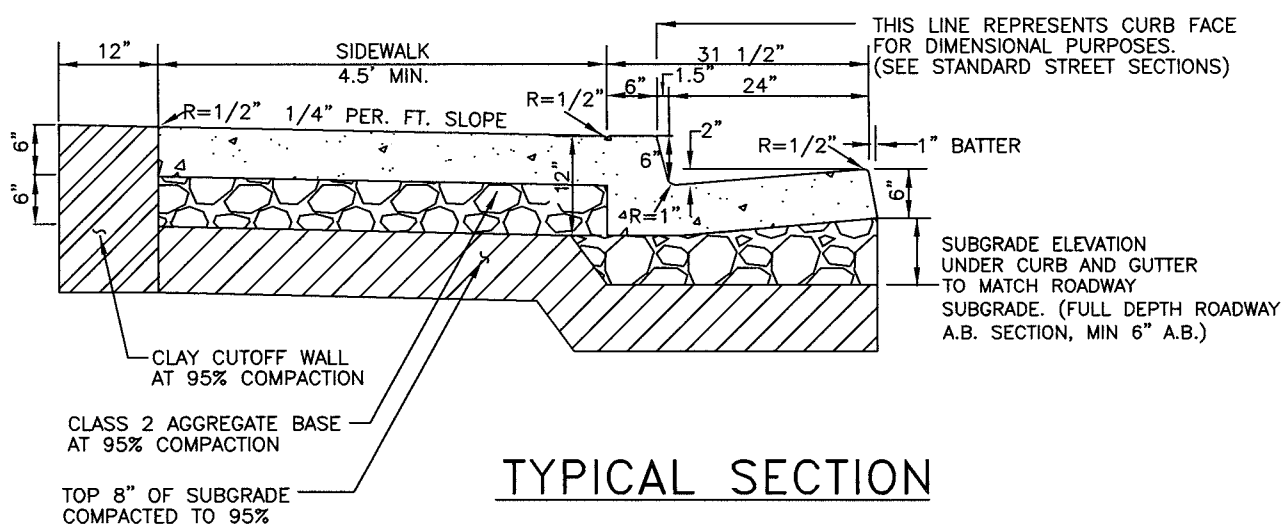

**TYPICAL SECTION**

**NOTES:**

1. CONCRETE SHALL BE CALTRANS CLASS A, 6-SACK, MIX DESIGN APPROVED BY COUNTY ENGINEER.
2. AGGREGATE BASE SHALL BE CALTRANS CLASS 2 AGGREGATE BASE MATERIAL APPROVED BY COUNTY ENGINEER.
3. SIDEWALK, CURB, AND GUTTER SHALL BE POURED MONOLITHICALLY.
4. COLD JOINTS SHALL BE DOWELED WITH 15" LONG #4 BARS AT 12" O.C.
5. EXPANSION JOINT SHALL BE 3/8" OR 1/2" THICK ASPHALT IMPREGNATED FELT.
6. SEWER AND WATER SERVICES SHALL BE ACCURATELY INDICATED WITH A 2" TALL "S" OR "W" LETTER STAMPED IN THE FACE OF THE CURB.
7. ALL EXPOSED CONCRETE EDGES SHALL HAVE 1/2" TOOLED RADIUS.
8. APPLY LIGHT BROOM FINISH TO SURFACE OF WALK PERPENDICULAR TO THE LENGTH OF THE SIDEWALK.
9. SIDEWALK WIDTHS SHALL AS BE SHOWN ON THE PLANS, BUT IN NO CASE LESS THAN 4.5' WIDE.
10. UNLESS OTHERWISE SHOWN, PROVIDE A 6' LONG TRANSITION TO CONNECT TO OTHER CURB TYPES.
11. SEE STANDARD COMMERCIAL DRIVEWAY DETAIL FOR COMMERCIAL DRIVEWAY REINFORCEMENT.
12. ALL AREAS OF CONCRETE EXHIBITING VISIBLE CRACKING OUTSIDE THE LIMITS OF TOOLED JOINT LINES SHALL BE REPLACED BY SAW CUTTING ALONG THE NEAREST TOOL JOINT AND REPLACING ALL THE CRACKED PANELS.

<b>COUNTY OF YOLO</b>		DATE:
PLANNING AND PUBLIC WORKS DEPARTMENT		08/05/08
<b>A2-6 VERTICAL CURB AND GUTTER</b>		SHEET #
		1 OF 1
<i>Parros Kalkas</i>		DRAWING #:
COUNTY ENGINEER No. C42401		4-19
28 AUG 08		NOT TO SCALE
APPROVAL DATE		

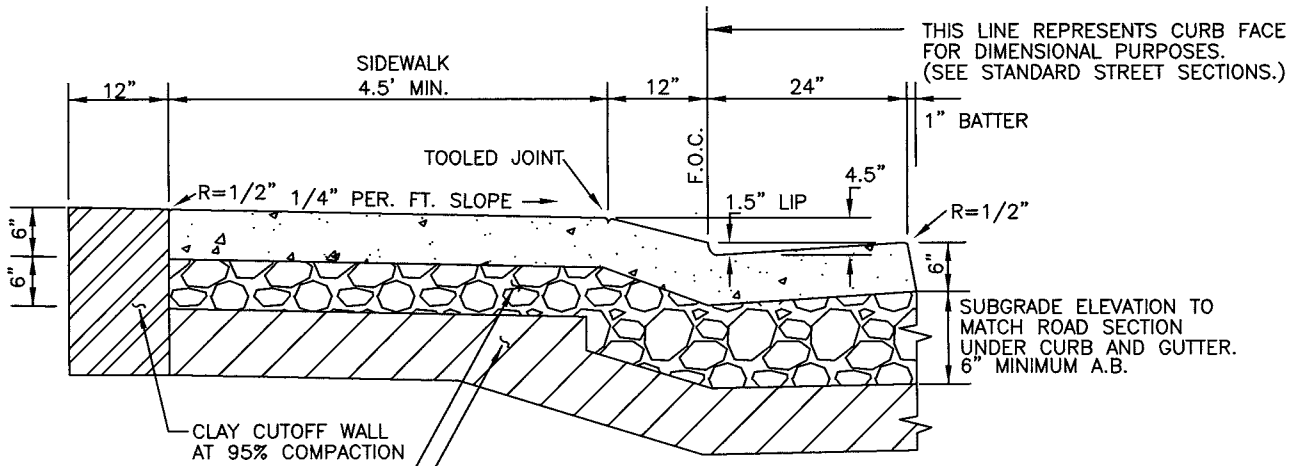

CLAY CUTOFF WALL  
AT 95% COMPACTION

CLASS 2 AGGREGATE BASE  
AT 95% COMPACTION

TOP 8" OF SUBGRADE  
COMPACTED TO 95%

### TYPICAL SIDEWALK SECTION

REQUIRES SPECIAL APPROVAL BY COUNTY ENGINEER.

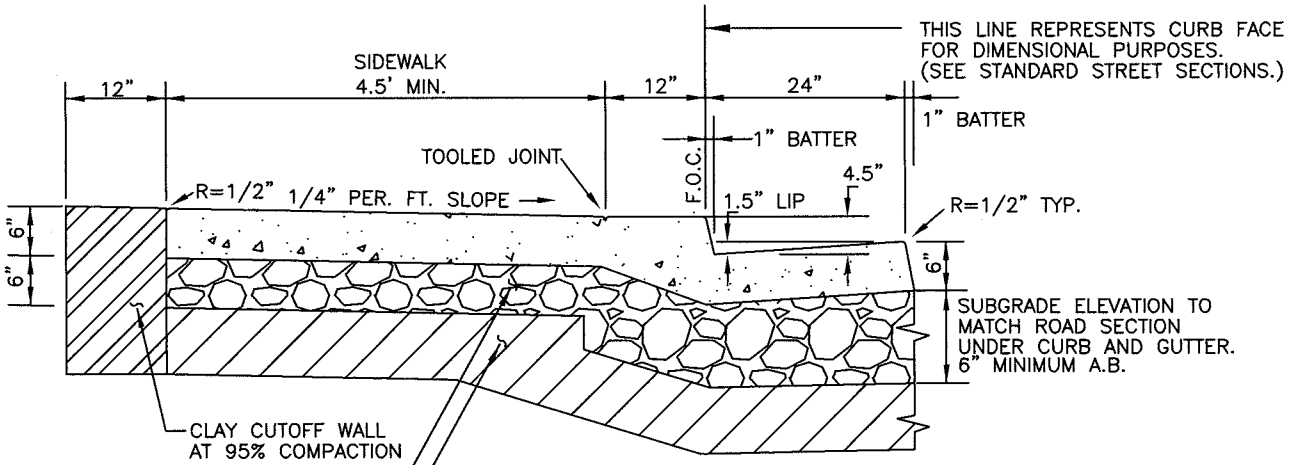

CLAY CUTOFF WALL  
AT 95% COMPACTION

CLASS 2 AGGREGATE BASE  
AT 95% COMPACTION

TOP 8" OF SUBGRADE  
COMPACTED TO 95%

### TYPICAL CURB RETURN SECTION

**NOTES:**

1. LOW PROFILE CURB AND GUTTER REQUIRES THE COUNTY ENGINEER'S APPROVAL ON A CASE BY CASE BASIS.
2. CONCRETE SHALL BE CALTRANS CLASS A, 6-SACK, MIX DESIGN APPROVED BY COUNTY ENGINEER.
3. AGGREGATE BASE SHALL BE CALTRANS CLASS 2 AGGREGATE BASE MATERIAL APPROVED BY COUNTY ENGINEER.
4. SIDEWALK, CURB, AND GUTTER SHALL BE POURED MONOLITHICALLY.
5. COLD JOINTS SHALL BE DOWELED WITH #4 BARS AT 12" O.C.
6. PROVIDE EXPANSION JOINTS AT 60' INTERVALS, DEEP TOOLED WEAKENED PLANE JOINTS AT 12' SPACING, AND CRACK CONTROL JOINTS AT 4' SPACING.
7. EXPANSION JOINTS SHALL BE 3/8" OR 1/2" THICK ASPHALT IMPREGNATED FELT.
8. SEWER AND WATER SERVICES SHALL BE ACCURATELY INDICATED WITH A 2" TALL "S" OR "W" LETTER STAMPED IN CONCRETE.
9. ALL EXPOSED CONCRETE EDGES SHALL HAVE 1/2" TOOLED RADIUS.
10. APPLY LIGHT BROOM FINISH TO SURFACE OF WALK PERPENDICULAR TO THE LENGTH OF THE SIDEWALK.
11. SIDEWALK WIDTHS SHALL AS BE SHOWN ON THE PLANS, BUT IN NO CASE LESS THAN 4.5' WIDE.
12. UNLESS OTHERWISE SHOWN, PROVIDE A 6' LONG TRANSITION TO CONNECT TO OTHER CURB TYPES.
13. ALL AREAS OF CONCRETE EXHIBITING VISIBLE CRACKING OUTSIDE THE LIMITS OF TOOLED JOINT LINES SHALL BE REPLACED BY SAW CUTTING ALONG THE NEAREST TOOL JOINT AND REPLACING ALL THE CRACKED PANELS.

COUNTY OF YOLO  
PLANNING AND PUBLIC WORKS DEPARTMENT

DATE:  
08/05/08

LOW PROFILE CURB AND GUTTER

SHEET #  
1 OF 1

*Panos Kollas*  
COUNTY ENGINEER No. C42401

28 AUG. 08  
APPROVAL DATE

DRAWING #:  
4-20  
NOT TO SCALE



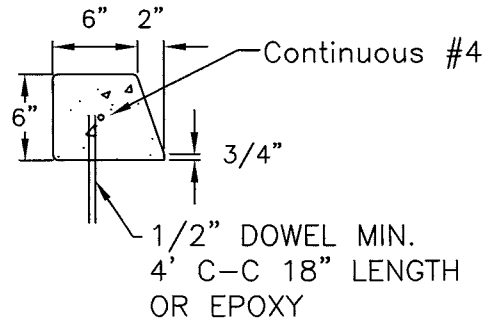
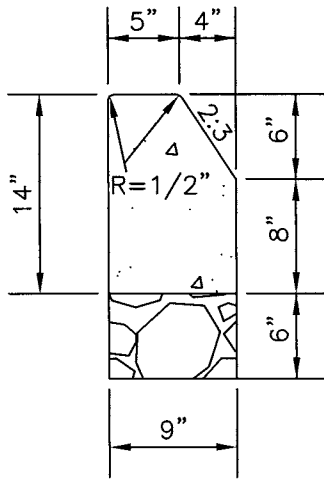

**MEDIAN CURB  
RETROFIT ONLY**

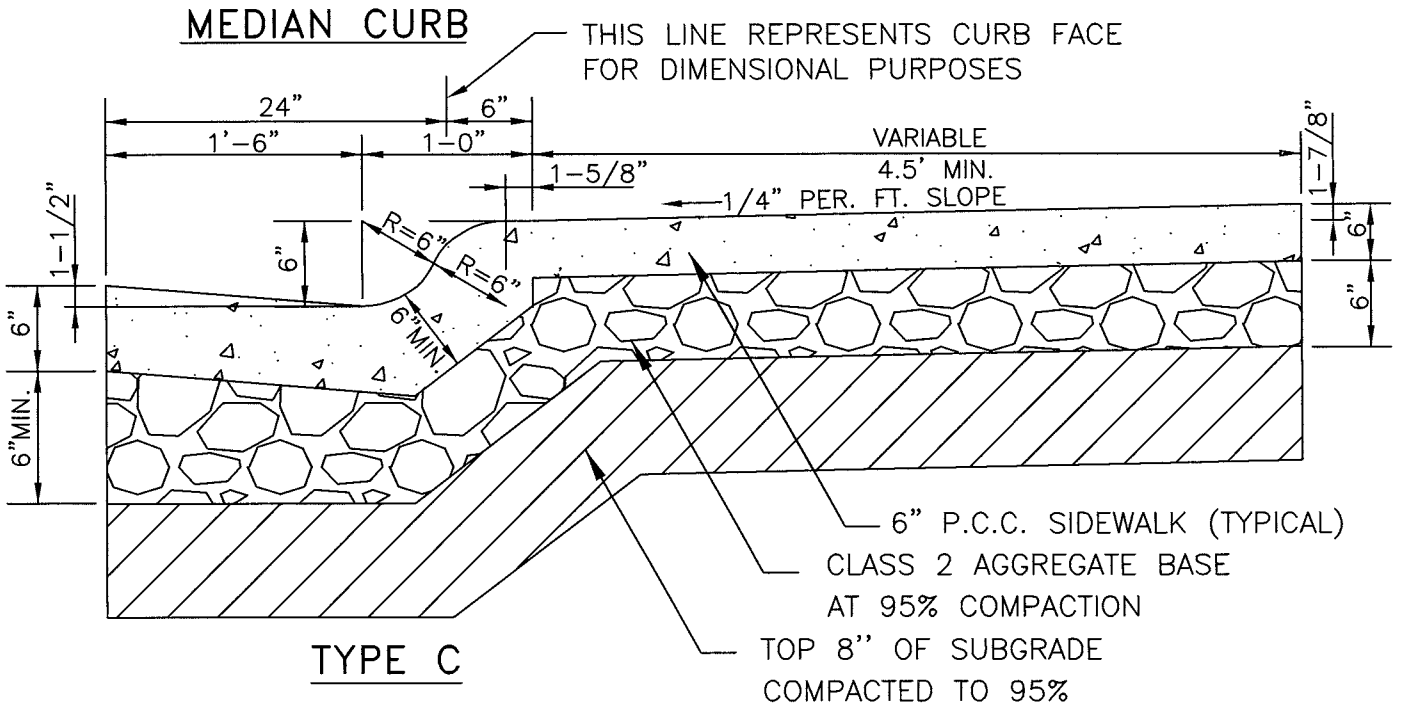

**USED ONLY TO MATCH EXISTING AND  
REQUIRES COUNTY ENGINEER APPROVAL**

**NOTES:**

1. CONCRETE SHALL BE CALTRANS CLASS A, 6-SACK, MIX DESIGN APPROVED BY THE COUNTY ENGINEER.
2. AGGREGATE BASE SHALL BE CALTRANS CLASS 2 AGGREGATE BASE MATERIAL APPROVED BY THE COUNTY ENGINEER.
3. SIDEWALK, CURB, AND GUTTER SHALL BE POURED MONOLITHICALLY.
4. COLD JOINTS SHALL BE DOWELED WITH 15" LONG #4 BARS AT 12" O.C.
5. EXPANSION JOINT SHALL BE 3/8" OR 1/2" THICK ASPHALT IMPREGNATED FELT.
6. SEWER AND WATER SERVICES SHALL BE ACCURATELY INDICATED WITH A 2" TALL "S" OR "W" LETTER STAMPED IN THE FACE OF THE CURB.
7. ALL EXPOSED CONCRETE EDGES SHALL HAVE 1/2" TOOLED RADIUS.
8. APPLY LIGHT BROOM FINISH TO SURFACE OF WALK PERPENDICULAR TO THE LENGTH OF THE SIDEWALK.
9. SIDEWALK WIDTHS SHALL AS BE SHOWN ON THE PLANS, BUT IN NO CASE LESS THAN 4.5' WIDE.
10. UNLESS OTHERWISE SHOWN, PROVIDE A 6' LONG TRANSITION TO CONNECT TO OTHER CURB TYPES.
11. SEE STANDARD COMMERCIAL DRIVEWAY DETAIL FOR COMMERCIAL DRIVEWAY REINFORCEMENT.

<b>COUNTY OF YOLO</b>		DATE:
PLANNING AND PUBLIC WORKS DEPARTMENT		08/05/08
<b>CURBS</b>		SHEET #
		1 OF 1
<i>Panos Kalkas</i>		DRAWING #:
COUNTY ENGINEER No. C42401	28 AUG. 08	4-21
	APPROVAL DATE	NOT TO SCALE

# DRIVEWAY TYPES

<u>DRIVEWAY</u> LIGHT	<u>USAGE</u> <u>RESIDENTIAL</u>
MEDIUM	<u>COMMERCIAL OR MULTI-FAMILY (4 OR MORE DWELLING UNITS)</u>
HEAVY	<u>INDUSTRIAL, MAJOR SHOPPING CENTERS</u>

# DESIGN STANDARDS

1. DRIVEWAY SLOPES AND GRADE CHANGES MUST MEET THE ADA REQUIREMENTS.
2. CONCRETE SHALL BE 6-SACK, CLASS A; 7 DAY MINIMUM CURE REQUIRED PRIOR TO OPENING FOR TRAFFIC.
3. DEEP TOOL JOINTS SHALL BE 1" DEEP OR  $\frac{1}{4}$  OF SECTION DEPTH, WHICHEVER IS GREATER.
4. SCORE LINES SHALL BE  $\frac{1}{4}$ " DEEP AND FORM A SQUARE PATTERN, PERPENDICULAR TO EDGES.
5. ALL EDGES SHALL HAVE  $\frac{1}{2}$ " TOOLED RADIUS.
6. SIDEWALK AND DRIVEWAY SHALL HAVE A LIGHT BROOM FINISH PERPENDICULAR TO STREET. CURB AND GUTTER SHALL HAVE A LIGHT BROOM FINISH PARALLEL TO STREET.
7. LOCATE DRIVEWAYS SUCH THAT THEY ARE A MINIMUM OF 5' FROM FEATURES SUCH AS FIRE HYDRANTS, UTILITY POLES, DRAINAGE INLETS, CROSSWALKS, CURB RETURNS, ETC.
8. DRIVEWAY SLOPE MAY NEED TO BE FLATTENED FOR HIGH CROWN STREETS TO AVOID BOTTOMING OR SCRAPING OF THE VEHICLES UNDERCARRIAGE.

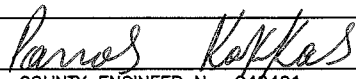
<b>COUNTY OF YOLO</b> PLANNING AND PUBLIC WORKS DEPARTMENT		DATE: 08/05/08
<b>STANDARD DRIVEWAY DETAILS</b>		SHEET # 1 OF 3
 COUNTY ENGINEER No. C42401	28 AUG 08 APPROVAL DATE	DRAWING #: 4-22

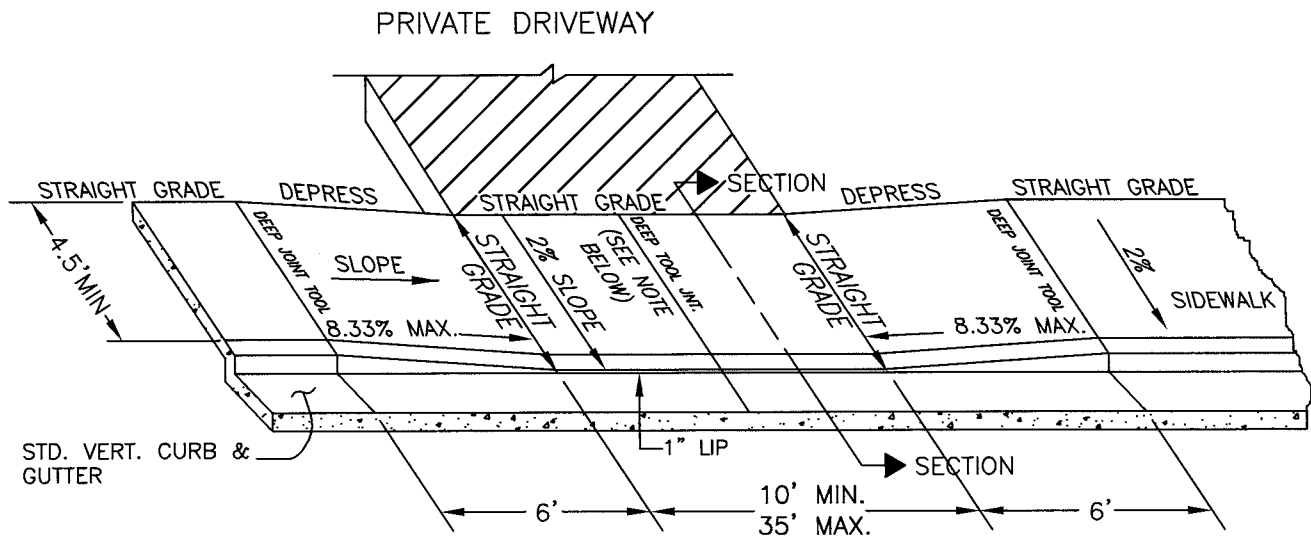

**STANDARD DRIVEWAY  
ADJACENT SIDEWALK**

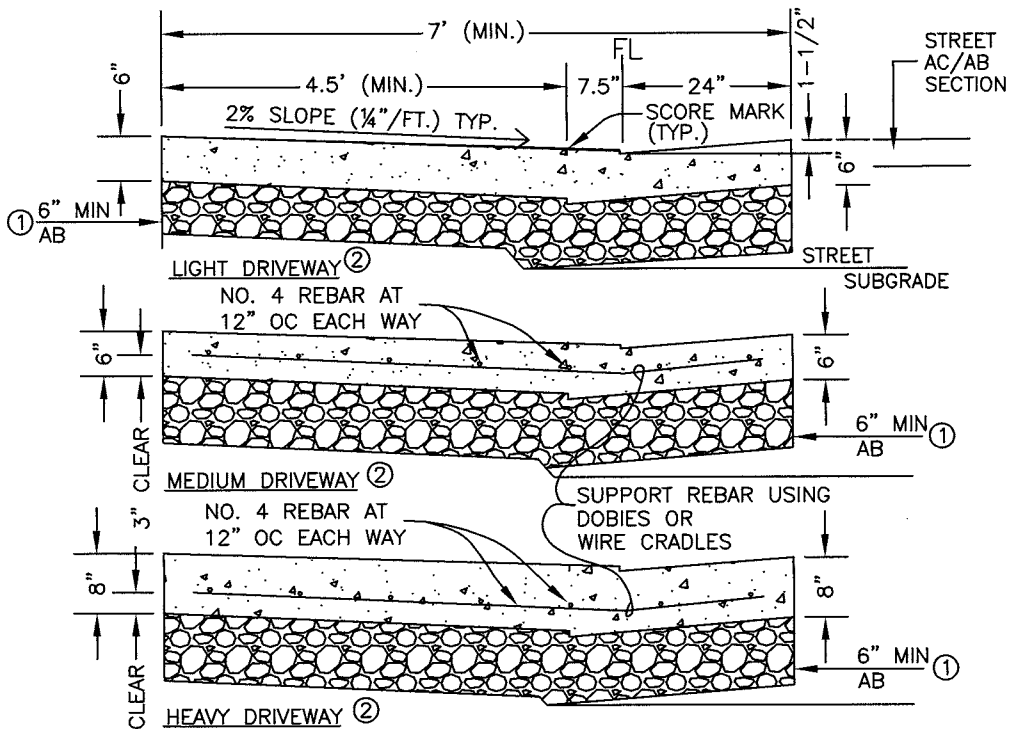

**TYPICAL TYPE 1 SECTIONS**

**NOTES:**

1. EXTEND TO ADJACENT STREET<sup>3</sup> SUBGRADE DEPTH, WHICHEVER IS DEEPER.
2. SEE "DRIVEWAY TYPES" SHEET 1.
3. DEPTH OF DEEP TOOL JOINT SHALL BE 1" MIN. OR 1/4 CONCRETE THICKNESS WHICHEVER IS GREATER.
4. AGGREGATE BASE SHALL BE MATERIAL MEETING CALTRANS CLASS II STANDARDS, COMPACTED TO 95% RELATIVE COMPACTION.
5. TOP 8" OF SUBGRADES SHALL BE COMPACTED TO 95% RELATIVE COMPACTION.
6. FELT EXPANSION JOINT NOT ALLOWED IN DRIVEWAY

<b>COUNTY OF YOLO</b> PLANNING AND PUBLIC WORKS DEPARTMENT		DATE: 08/05/08
<b>STANDARD DRIVEWAY DETAILS</b> <b>ADJACENT SIDEWALK</b>		SHEET # 2 OF 3
<i>Paros Kakkas</i> COUNTY ENGINEER No. C42401	28 AUG 08 APPROVAL DATE	DRAWING #: <b>4-22</b> NOT TO SCALE

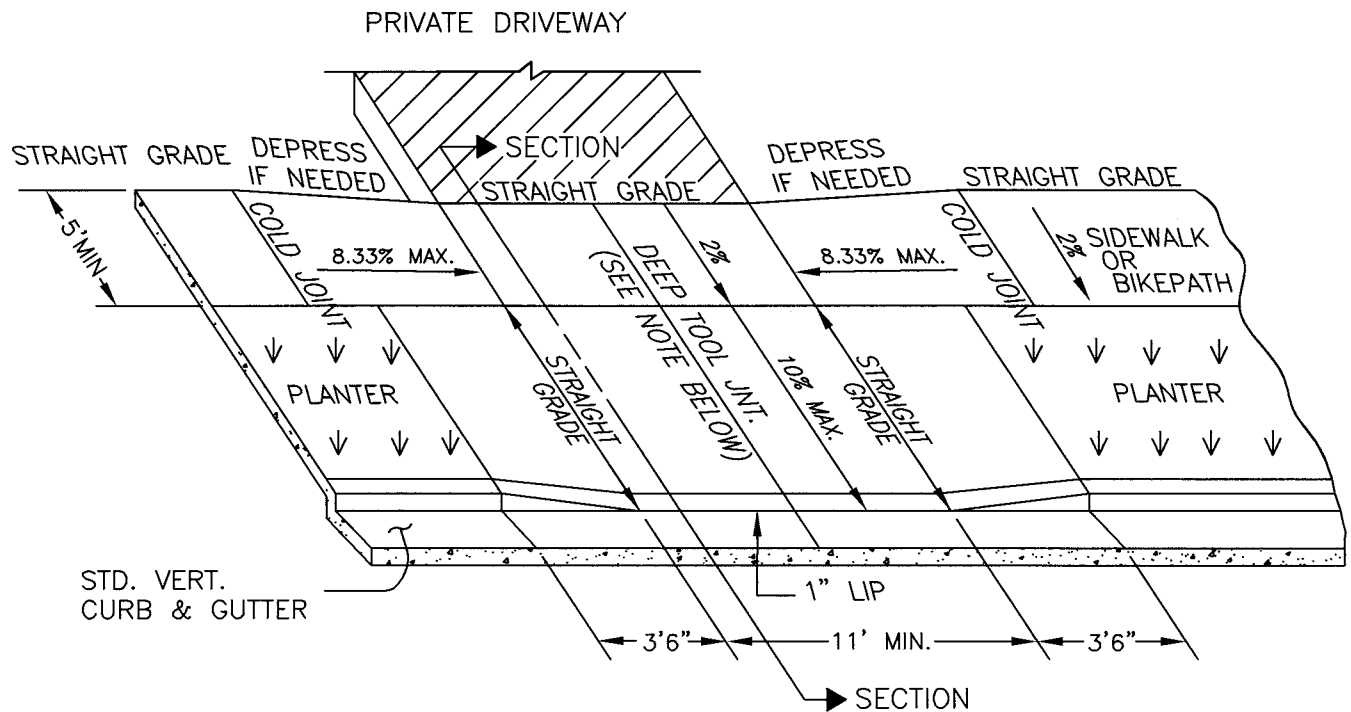

**STANDARD DRIVEWAY  
SEPARATED SIDEWALK**

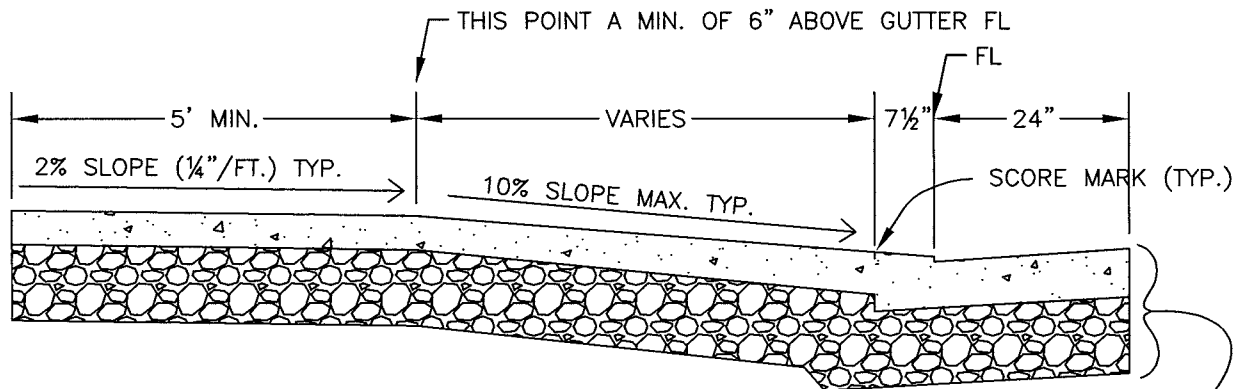

**TYPICAL SECTION**

SEE SHEET 2 FOR  
MATERIAL, THICKNESS,  
COMPACTION, AND  
REBAR REQUIREMENTS

**NOTE:**

1. DEPTH OF DEEP TOOL JOINT SHALL BE 1" MIN. OR 1/4 CONCRETE THICKNESS WHICHEVER IS GREATER.

<b>COUNTY OF YOLO</b> PLANNING AND PUBLIC WORKS DEPARTMENT		DATE: 08/05/08
<b>STANDARD DRIVEWAY DETAILS</b> <b>SEPARATED SIDEWALK</b>		SHEET # 3 OF 3
<i>Paros Kalkas</i> COUNTY ENGINEER No. C42401	28 AUG - 08 APPROVAL DATE	DRAWING #: <b>4-22</b> NOT TO SCALE

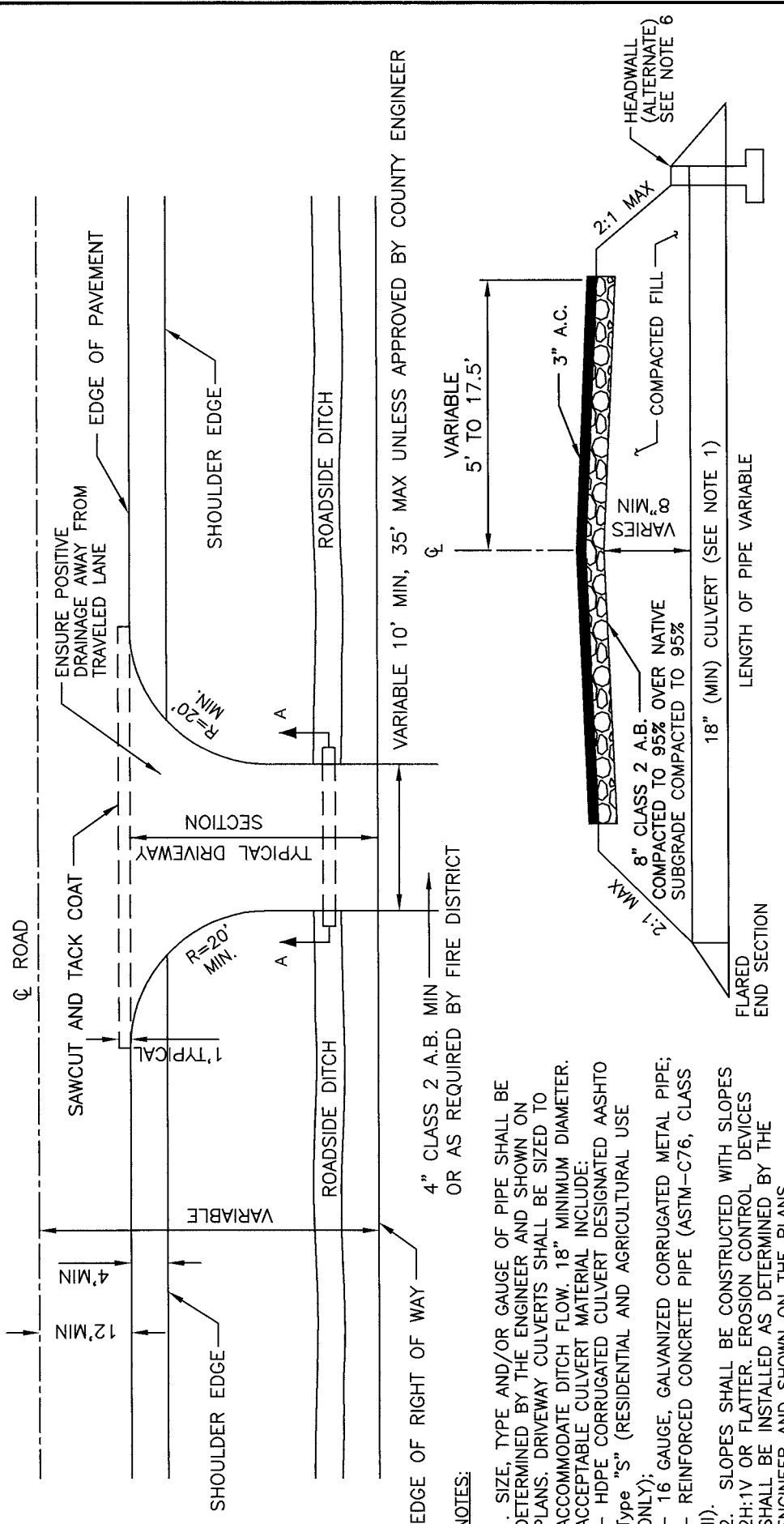

TYPICAL DRIVEWAY SECTION A-A

VARIABLE 10' MIN, 35' MAX UNLESS APPROVED BY COUNTY ENGINEER

4" CLASS 2 A.B. MIN OR AS REQUIRED BY FIRE DISTRICT

NOTES:

1. SIZE, TYPE AND/OR GAUGE OF PIPE SHALL BE DETERMINED BY THE ENGINEER AND SHOWN ON PLANS. DRIVEWAY CULVERTS SHALL BE SIZED TO ACCOMMODATE DITCH FLOW. 18" MINIMUM DIAMETER. ACCEPTABLE CULVERT MATERIAL INCLUDE:
  - HDPE CORRUGATED CULVERT DESIGNATED AASHTO Type "S" (RESIDENTIAL AND AGRICULTURAL USE ONLY);
  - 16 GAUGE, GALVANIZED CORRUGATED METAL PIPE;
  - REINFORCED CONCRETE PIPE (ASTM-C76, CLASS III).
2. SLOPES SHALL BE CONSTRUCTED WITH SLOPES 2H:1V OR FLATTER. EROSION CONTROL DEVICES SHALL BE INSTALLED AS DETERMINED BY THE ENGINEER AND SHOWN ON THE PLANS.
3. CONCRETE DRIVEWAYS SHALL NOT PROJECT INTO PUBLIC RIGHT OF WAY EXCEPT WHERE CLASS "A" IMPROVEMENTS ARE INSTALLED.
4. DRIVEWAY STRUCTURAL SECTION WITHIN RIGHT OF WAY: 3" ASPHALT CONCRETE OVER 8" AGGREGATE BASE ON COMPACTED SUBGRADE MATERIAL.
5. WHERE GRADES MAKE IT IMPOSSIBLE TO INSTALL DRIVEWAY CULVERTS, THE DRIVEWAY SHALL BE GRADED SUCH THAT DRAINAGE SHALL NOT BE OBSTRUCTED IN ANY MANNER.
6. HEADWALLS SHALL NOT PROJECT ABOVE THE ADJACENT GRADE.
7. DRIVEWAY OR CULVERT WITHIN THE PUBLIC RIGHT OF WAY SHALL BE THE RESPONSIBILITY OF THE PROPERTY OWNER.

COUNTY OF YOLO PLANNING AND PUBLIC WORKS DEPARTMENT	DATE: 08/05/08
RURAL ROAD - DRIVEWAY DETAIL	SHEET # 1 OF 1
<i>James Kallas</i> COUNTY ENGINEER No. C42401	DRAWING #: 4-23 NOT TO SCALE
<i>28 Aug. 08</i> APPROVAL DATE	

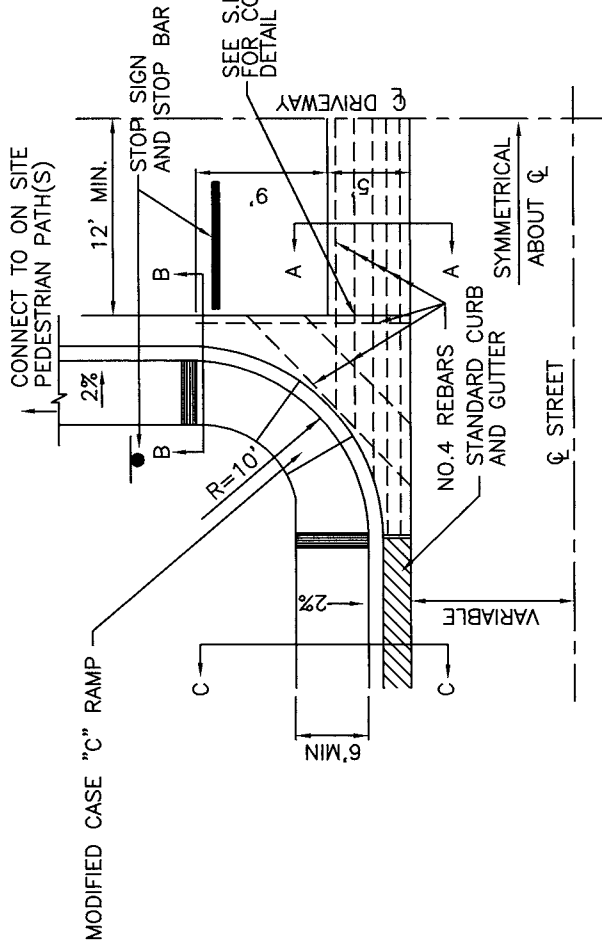

PLAN VIEW  
(ADJACENT SIDEWALK)  
R/W LINE

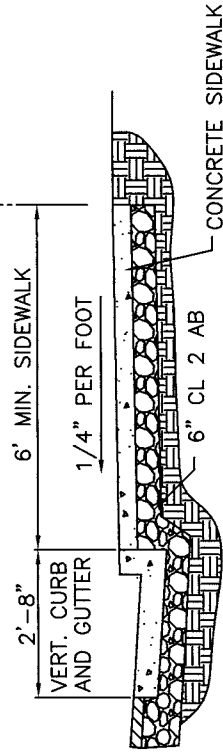

SECTION C-C  
(ADJACENT SIDEWALK)

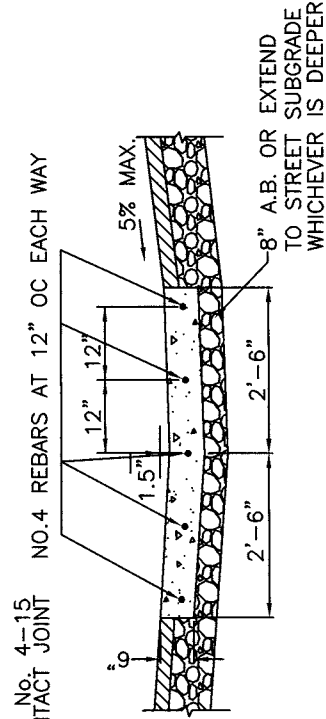

SECTION A-A  
DRIVEWAY SLOPE NOT TO EXCEED 5% FOR A MINIMUM OF 20' FROM EDGE OF PAVEMENT.

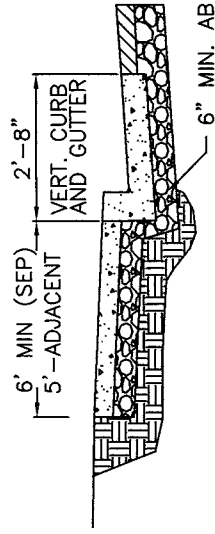

SECTION B-B

**NOTE:**

1. REFER TO CALTRANS STANDARD PLANS FOR HANDICAP RAMP DETAILS.

COUNTY OF YOLO PLANNING AND PUBLIC WORKS DEPARTMENT	DATE: 08/05/08
SPECIAL COMMERCIAL FRONTAGE ENTRANCE	SHEET # 1 OF 2
<i>Parsons</i> COUNTY ENGINEER No. C42401	DRAWING #: 4-24 NOT TO SCALE
<i>28 Aug. 08</i> APPROVAL DATE	

PLAN VIEW  
(SEPARATED SIDEWALK)

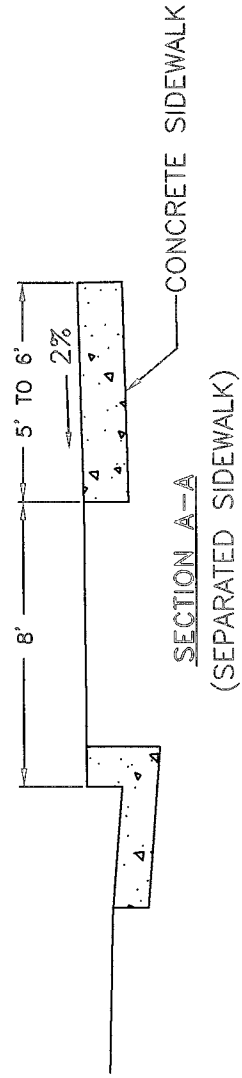
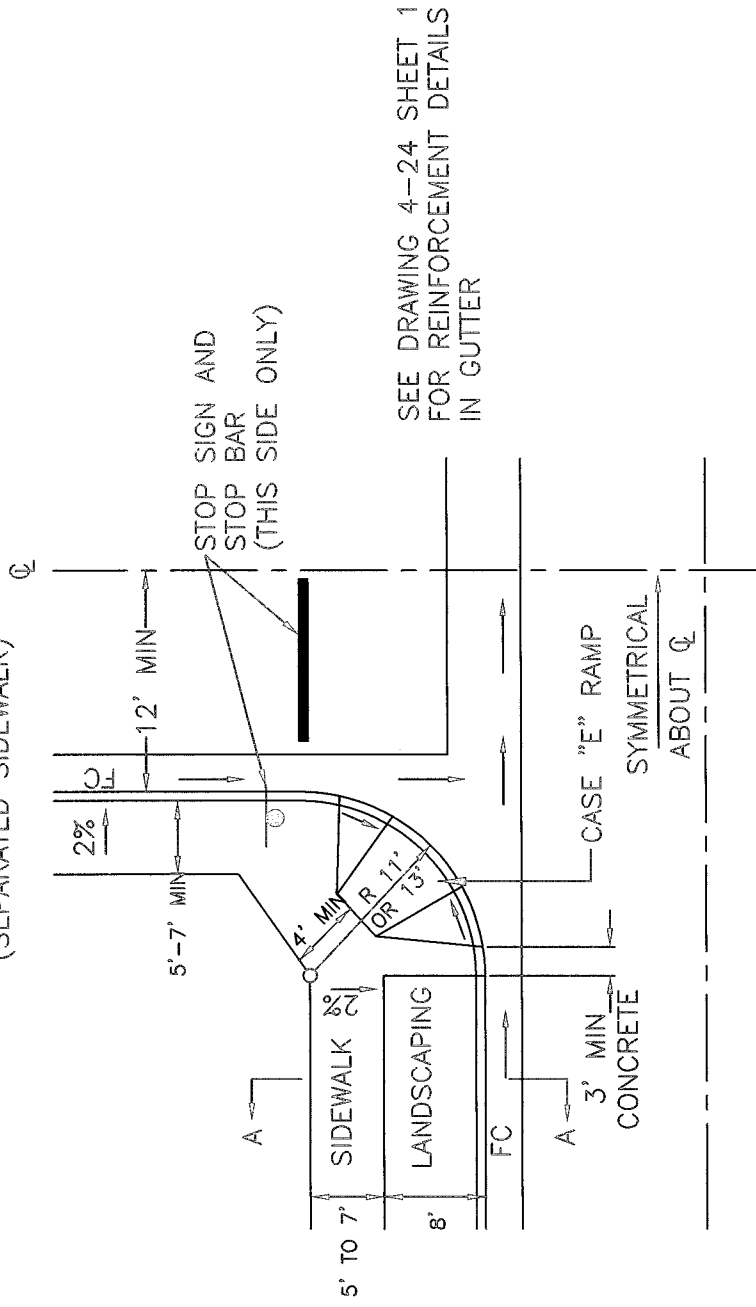

DATE: 08/05/08	COUNTY OF YOLO PLANNING AND PUBLIC WORKS DEPARTMENT
SHEET # 2 OF 2	SPECIAL COMMERCIAL FRONTAGE ENTRANCE
DRAWING #: 4-24	APPROVAL DATE 28 AUG 08
NOT TO SCALE	COUNTY ENGINEER No. C42401 <i>Parvash Kulkarni</i>

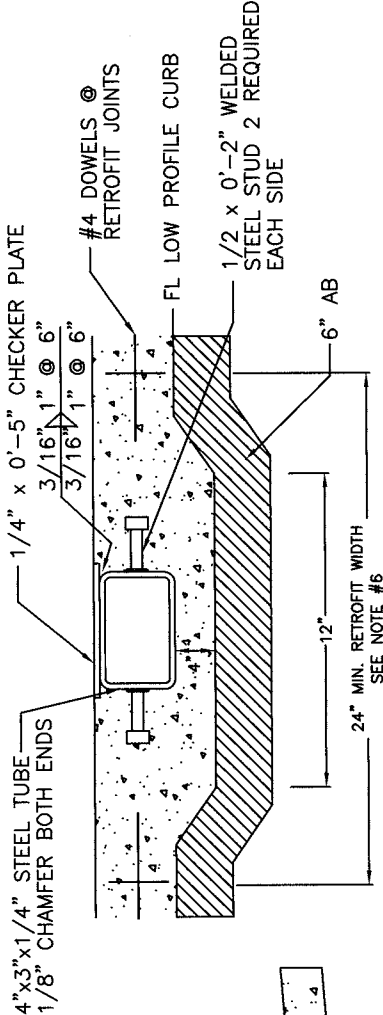
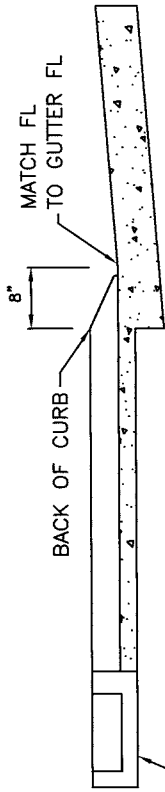
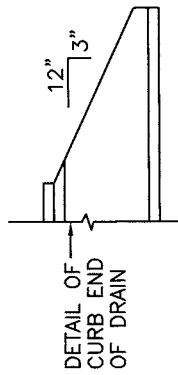

24" MIN. RETROFIT WIDTH  
SEE NOTE #6

SECTION B-B

SECTION A-A  
(FOR LOW PROFILE CURB)

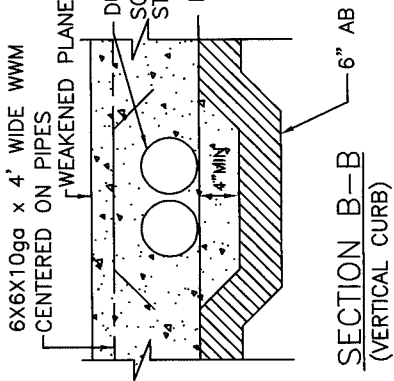

SECTION B-B  
(VERTICAL CURB)

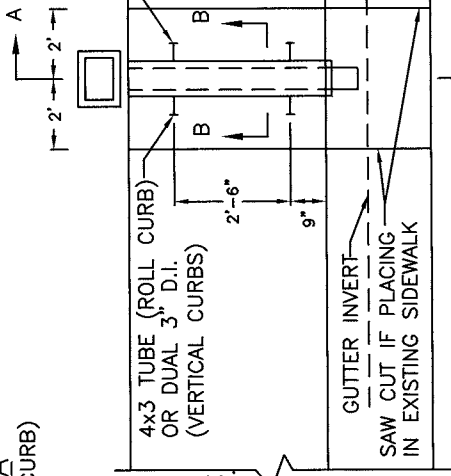

PLAN VIEW OF CURB, GUTTER AND SIDEWALK

NOTES:

1. UNDER SIDEWALK DRAINS TO BE USED ONLY WHERE LOT DOES NOT DRAIN OVER SIDEWALK OR WHERE A STORM DRAIN DOES NOT EXIST AND EXTENSION OF STORM DRAIN IS IMPRACTICAL.
2. ADJACENT PROPERTY OWNER SHALL CLEAN AND MAINTAIN DRAIN.
3. EXTEND TUBE OR PIPES ACROSS PLANTER STRIP AND THRU CURB IF SEPARATED SIDEWALK.
4. HOT DIP GALVANIZE AFTER FABRICATION.
5. ADJACENT PROPERTY OWNER SHALL BE RESPONSIBLE FOR BACKFLOW PROTECTION MEASURES TO ENSURE THAT DURING STORM EVENTS STREET GUTTER DOES NOT BACKFLOW ONTO PROPERTY.
6. FOR RETROFITS ADJUST WIDTH AS REQ'D SO SAWCUTS ARE LOCATED AT EXISTING JOINTS.

DATE: 08/05/08	COUNTY OF YOLO PLANNING AND PUBLIC WORKS DEPARTMENT
SHEET # 1 OF 1	UNDER SIDEWALK DRAIN
DRAWING #: 4-25 NOT TO SCALE	<i>James Hobbes</i> COUNTY ENGINEER No. C42401 28 AUG. 08 APPROVAL DATE



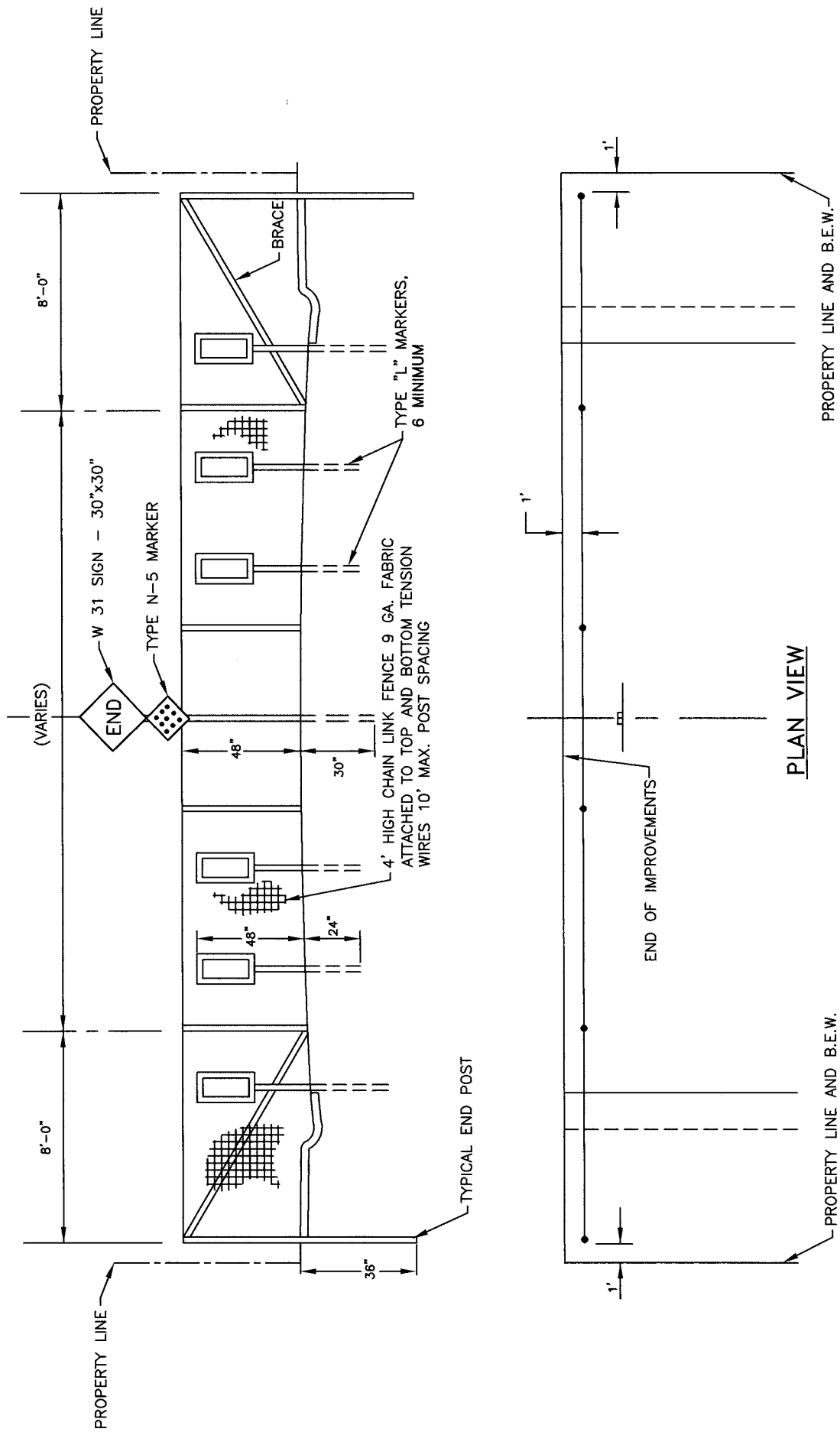

**NOTES:**

1. END POSTS TO BE 1-1/2" I.D. STANDARD WEIGHT PIPE WITH 8"x36" FOOTING.
2. BRACES AND LINE POSTS TO BE 1-1/4" STANDARD WEIGHT PIPE WITH 8"x30" FOOTING.

DATE:	08/05/08
SHEET #	1 OF 2
DRAWING #:	4-26
COUNTY ENGINEER No. C42401	APPROVAL DATE
COUNTY OF YOLO PLANNING AND PUBLIC WORKS DEPARTMENT <b>SIGNS AND BARRICADES AT          TEMPORARY STREET ENDS</b>	
<i>Parsons</i> COUNTY ENGINEER No. C42401	
<i>28 AUG. 08</i> APPROVAL DATE	
NOT TO SCALE	

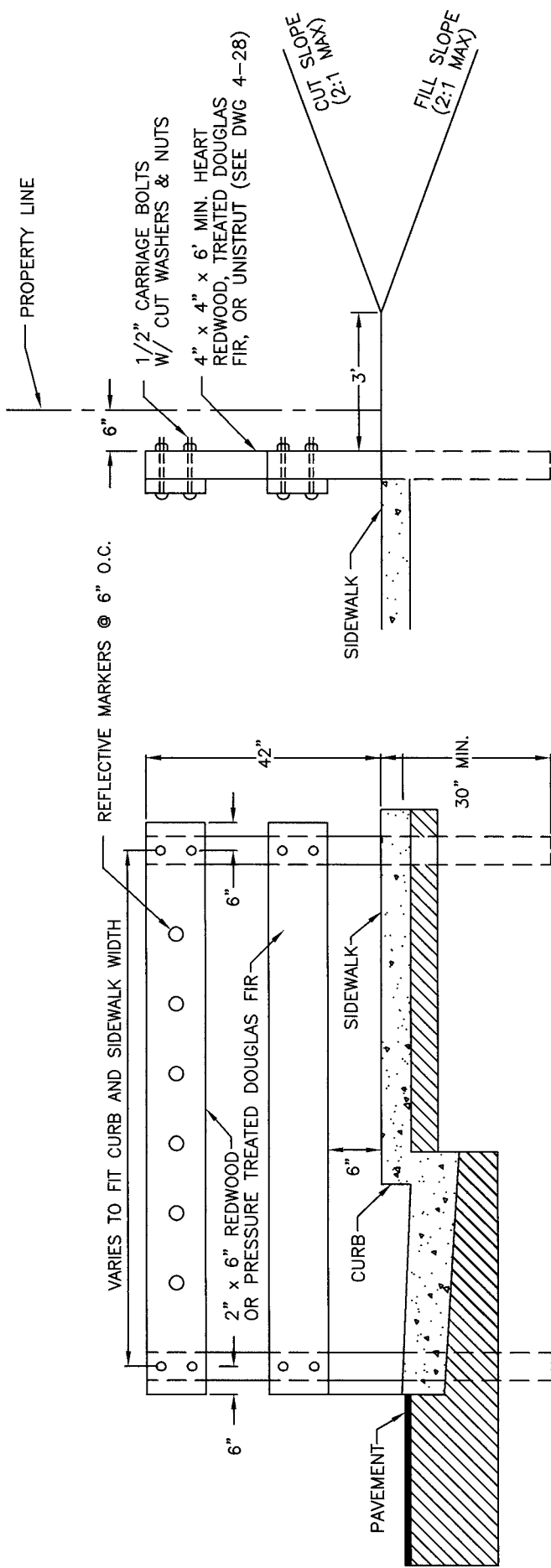

**NOTES:**

1. SIDEWALK BARRICADES TO BE ERECTED AT EACH LOCATION WHERE SATISFACTORY PROVISION CAN NOT BE MADE FOR PEDESTRIAN TO CONTINUE BEYOND THE TERMINUS OF A SIDEWALK.
2. ALL EXPOSED SURFACES TO BE PAINTED WITH TWO (2) COATS OF WHITE PAINT CONFORMING TO SECTION 91-3.02 OF STATE SPECIFICATIONS.

COUNTY OF YOLO PLANNING AND PUBLIC WORKS DEPARTMENT	DATE: 08/05/08
SIDEWALK BARRICADE	SHEET # 2 OF 2
<i>Paros Kokkas</i> COUNTY ENGINEER No. C42401	DRAWING #: 4-26 NOT TO SCALE
APPROVAL DATE 28 AUG 08	

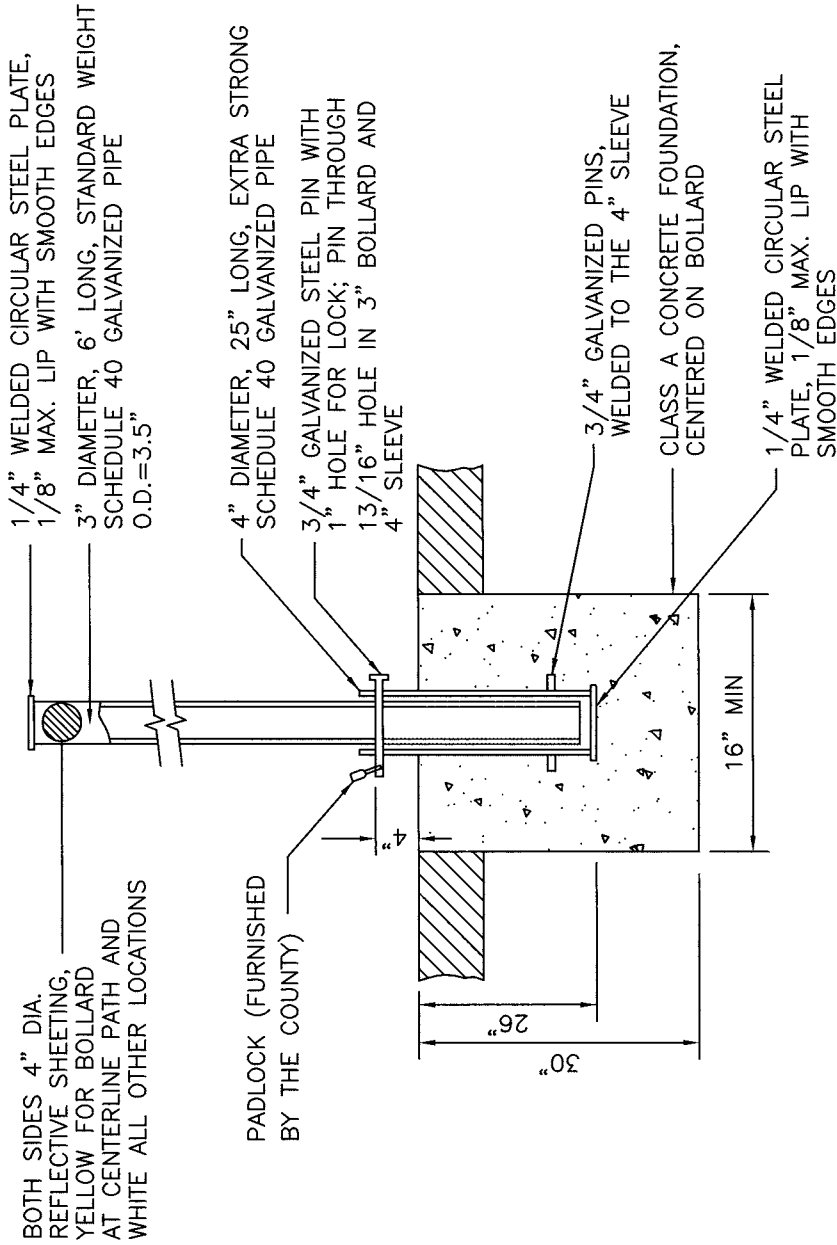

**NOTES:**

1. BOLLARD AND SLEEVE SHALL BE SPRAY PAINTED WITH TWO COATS OF HIGH GLOSS WHITE RUST INHIBITIVE PAINT ON TOP OF ONE COAT OF PRIMER.
2. A GATE MIGHT BE REQUIRED INSTEAD OF REMOVABLE BOLLARDS AT REQUEST OF THE COUNTY ENGINEER.

COUNTY OF YOLO PLANNING AND PUBLIC WORKS DEPARTMENT		DATE: 08/05/08
REMOVABLE BOLLARD		SHEET # 1 OF 1
<i>Pamela Kallal</i> COUNTY ENGINEER No. C42401	28 AUG 08 APPROVAL DATE	DRAWING #: 4-27 NOT TO SCALE

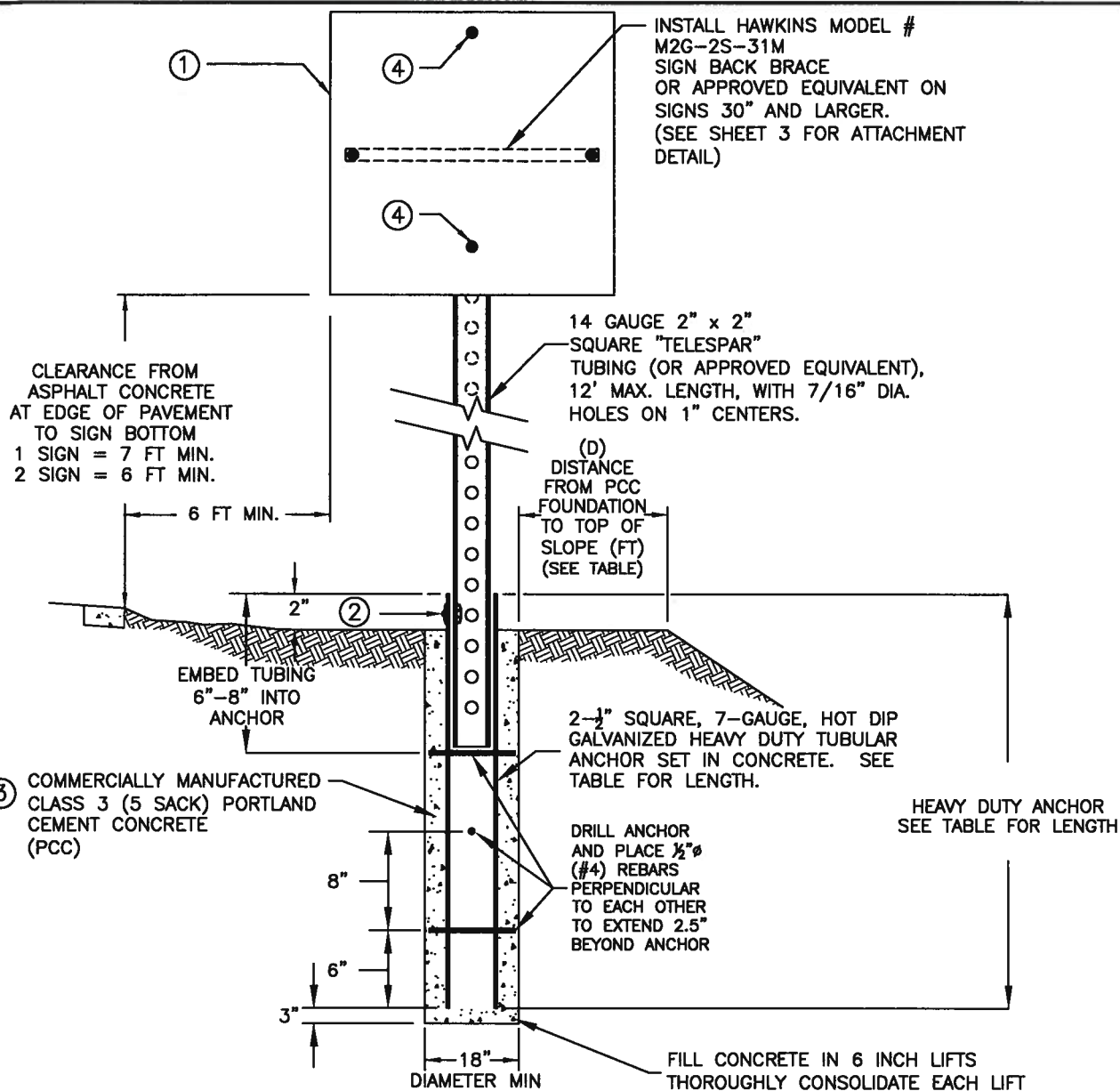

**NOTES:**

DISTANCE (D) FROM PCC TO TOP OF SLOPE (FT)	HEAVY DUTY ANCHOR LENGTH (IN)
$D > 3.0$	30" TELES PAR (ALLIED TUBE & CONDUIT, PART NO. HDA200-30-G, OR EQ.)
$2.0 < D \leq 3.0$	36" TELES PAR (ALLIED TUBE & CONDUIT PART NO. HDA200-36-G, OR EQ.)
$D < 2.0$	SPECIAL DESIGN

- "R1-1 SIGNS SHALL BE "EXPRESSWAY" SIZE, AND ALL OTHER SIGNS SHALL BE "CONVENTIONAL ROAD" SIZE, AS DESCRIBED IN THE CALIFORNIA MUTCD, LATEST EDITION, TABLES 2B-1 AND 2C-2".
- 3/8" ALUMINUM DRIVE RIVETS (TELES PAR PART NO. DRAS3878-06, OR APPROVED EQUIVALENT.) PLACE DRIVE RIVETS AS SHOWN ON SHEET 3 OF 3.
- CONCRETE SHALL CURE A MINIMUM OF 7 DAYS PRIOR TO INSTALLING SIGN.
- 5/16" DIA. X 3" GALV. CARRIAGE BOLT (SEE SHEET 3 FOR ATTACHMENT DETAIL).
- REFER TO THE LATEST EDITION OF THE CALIFORNIA MUTCD FOR STANDARDS NOT SHOWN HERE.
- ALL SIGNS SHALL BE PLACED WITHIN COUNTY ROAD RIGHT OF WAY.

<b>COUNTY OF YOLO</b>		DATE:
PLANNING AND PUBLIC WORKS DEPARTMENT		5/6/2013
<b>STREET SIGN ASSEMBLY-RURAL</b>		SHEET #
<i>Paras Koffel</i>		1 OF 3
COUNTY ENGINEER No. C42401		DRAWING #:
7 MAY 2013		4-28
APPROVAL DATE		NOT TO SCALE

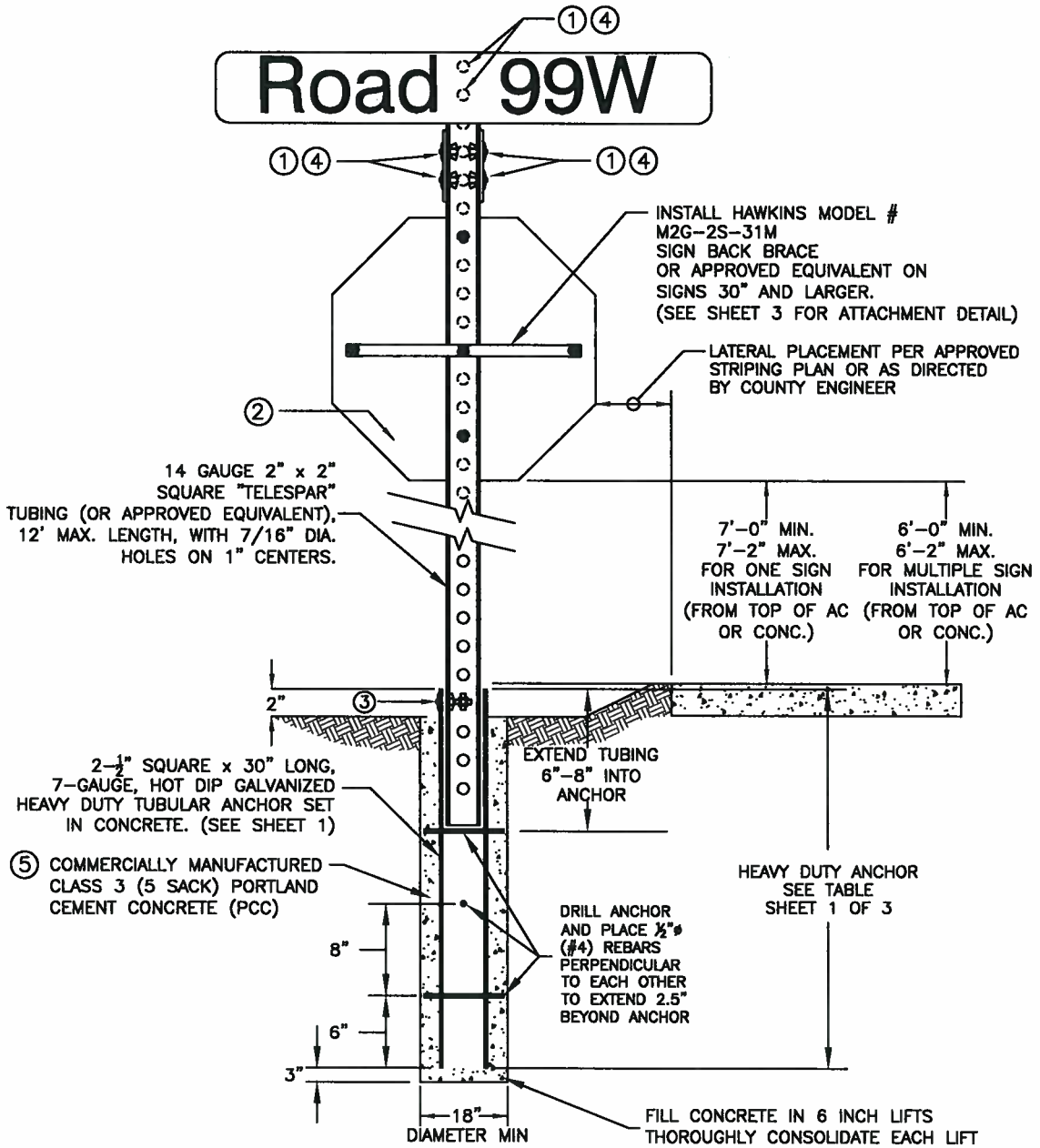

**NOTES:**

1. 9" TALL X 0.080" ALUMINUM SIGN PLATE WITH WHITE LETTERS (6" HIGH INITIAL UPPER-CASE LETTERS, 4.5" HIGH LOWER CASE LETTERS) ON GREEN REFLECTIVE BACKGROUND. SINGLE FACED. DO NOT INCLUDE BLOCK NUMBERS. SEE IMPROVEMENT STANDARD FOR PRIVATE ROAD SIGN STANDARD.
2. "R1-1 SIGNS SHALL BE "EXPRESSWAY" SIZE, AND ALL OTHER SIGNS SHALL BE "CONVENTIONAL ROAD" SIZE, AS DESCRIBED IN THE CALIFORNIA MUTCD, LATEST EDITION, TABLES 2B-1 AND 2C-2".
3. 3/8" ALUMINUM DRIVE RIVETS (TELESPAR PART NO. DRAS3878-06, OR APPROVED EQUIVALENT). PLACE DRIVE RIVETS AS SHOWN ON SHEET 3 OF 3.
4. (2) GREEN 3/8" ALUMINUM DRIVE RIVETS PER SIGN. PLACE DRIVE RIVETS AS SHOWN ON SHEET 3 OF 3.
5. CONCRETE SHALL CURE A MINIMUM OF 7 DAYS PRIOR TO INSTALLING SIGN.
6. ALL SIGNS SHALL BE PLACED WITHIN COUNTY ROAD RIGHT OF WAY.

<b>COUNTY OF YOLO</b> PLANNING AND PUBLIC WORKS DEPARTMENT		DATE: 5/6/2013
<b>STREET SIGN ASSEMBLY-SUBDIVISION</b>		SHEET # 2 OF 3
<i>Paras Kallias</i> COUNTY ENGINEER No. C42401		DRAWING #: 4-28 NOT TO SCALE
7 MAY 2013 APPROVAL DATE		

# SIGN STANDARDS AND DETAILS

## SHEETING (BACKGROUND)

3M TYPE XI DIAMOND GRADE 3 SERIES 4000 PRISMATIC SHEETING

- A. WHITE—REGULATORY SIGNS AND GUIDE SIGNS (STREET NAMES)
- B. FLUORESCENT YELLOW—WARNING SIGNS
- C. FLUORESCENT ORANGE—CONSTRUCTION SIGNS
- D. FLUORESCENT YELLOW/GREEN—SCHOOL, PEDESTRIAN AND BICYCLE SIGNS

## SHEETING (FOREGROUND)

3M ELECO CUT FILM (E.C. FILM) SERIES 1170

- A. RED—REGULATORY SIGNS
- B. GREEN—GUIDE SIGNS (STREET NAMES)
- C. BLUE—DISABLED PERSONS (ADA) AND TOURIST SIGNS
- D. BROWN—RECREATIONAL AND CULTURAL SIGNS

## LEGENDS AND TEXT

3M SCOTCHCAL ELECTRO CUT FILM SERIES 7725

- A. BLACK

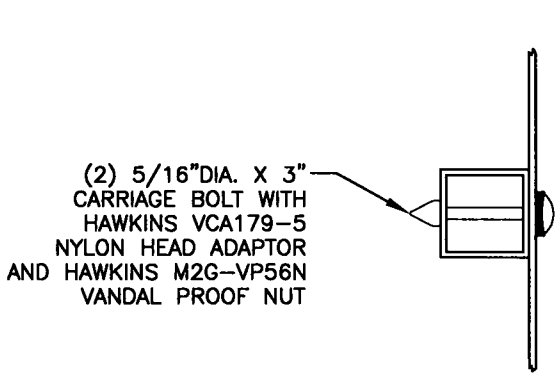

SIGN ATTACHMENT DETAIL

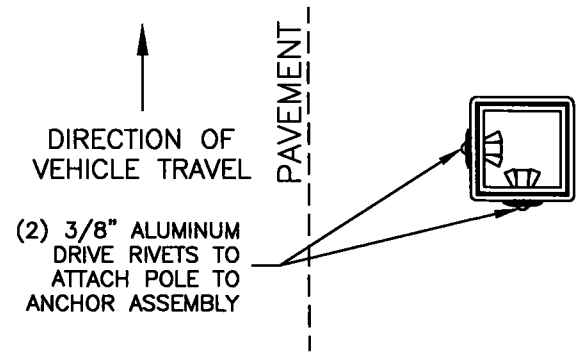

SIGN POST TO ANCHOR ATTACHMENT DETAIL

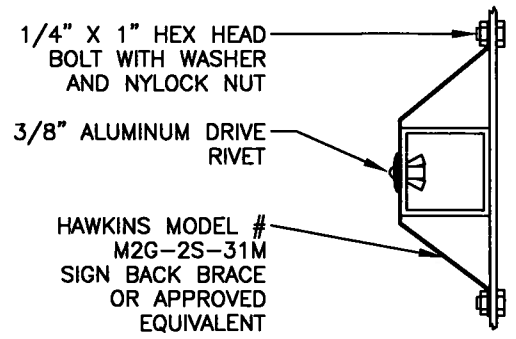

BRACE ATTACHMENT DETAIL

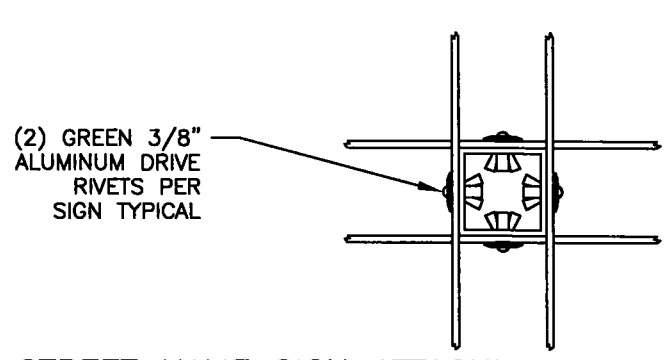

STREET NAME SIGN ATTACHMENT DETAIL

<b>COUNTY OF YOLO</b> PLANNING AND PUBLIC WORKS DEPARTMENT	DATE: 5/6/2013
<b>SIGN STANDARDS AND DETAILS</b>	SHEET # 3 OF 3
 COUNTY ENGINEER No. C42401	DRAWING #: 4-28 NOT TO SCALE
7 MAY 2013 APPROVAL DATE	

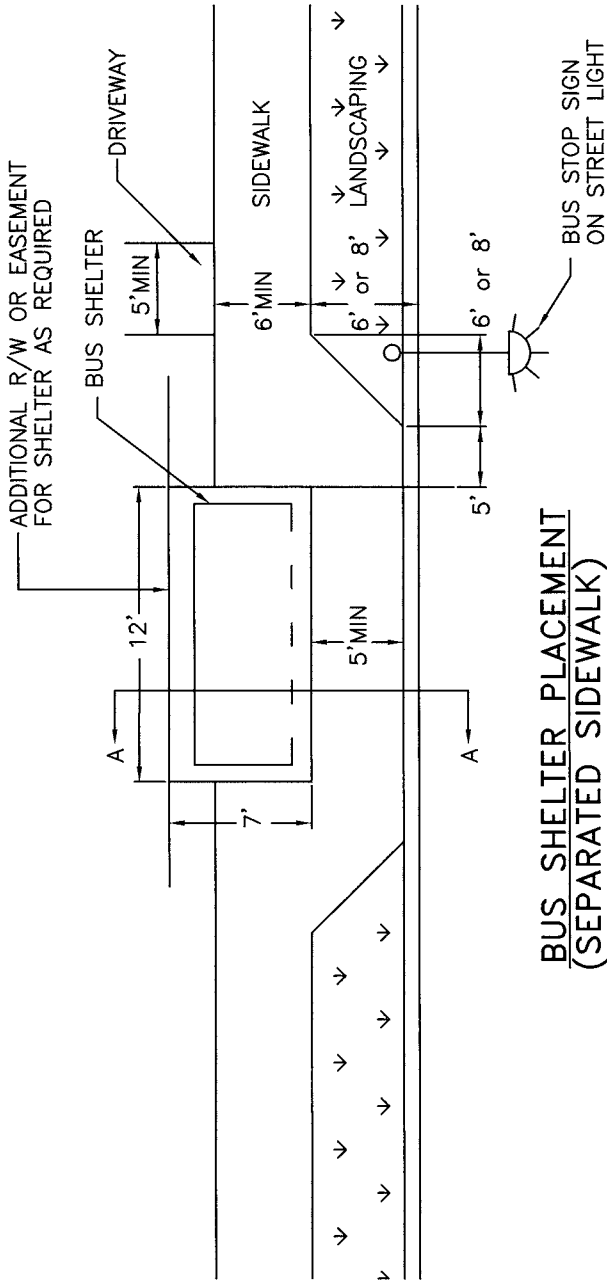

**BUS SHELTER PLACEMENT  
(SEPARATED SIDEWALK)**

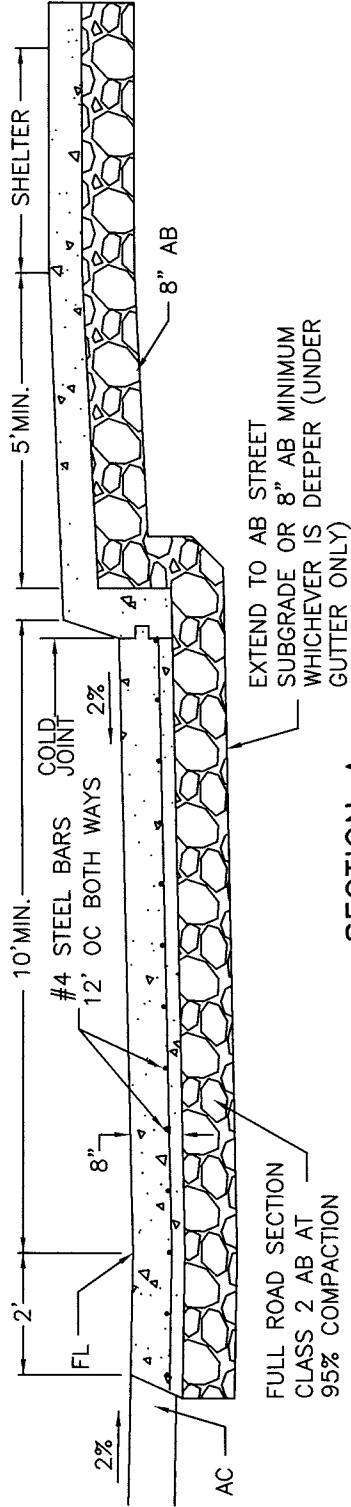

**SECTION A**

**NOTES:**

1. SECTION 'A' SHALL BE USED FOR THE GUTTER 50 FEET EACH SIDE OF BUS STOPS WITHOUT TURNOUTS. THE REBAR SHALL BE CONTINUED ACROSS ANY DRIVEWAYS WITHIN THE 50 FOOT DISTANCE FROM THE BUS STOP.
2. BUS SHELTER DETAILS AND BUS STOP SIGNAGE SHALL BE APPROVED BY YOLO COUNTY TRANSPORTATION DISTRICT.
3. CLASS A CONCRETE, 6 SACK MIX, FINISHED AND CURED IN ACCORDANCE WITH CALTRANS SPECIFICATIONS. PROVIDE TOOLED CRACK CONTROL JOINTS AS DIRECTED BY COUNTY ENGINEER.

PLANNING AND PUBLIC WORKS DEPARTMENT	DATE: 08/05/08
BUS STOP	SHEET # 1 OF 3
<i>James Walker</i> COUNTY ENGINEER No. C42401	DRAWING #: 4-29 NOT TO SCALE
APPROVAL DATE: 28 Aug. 08	

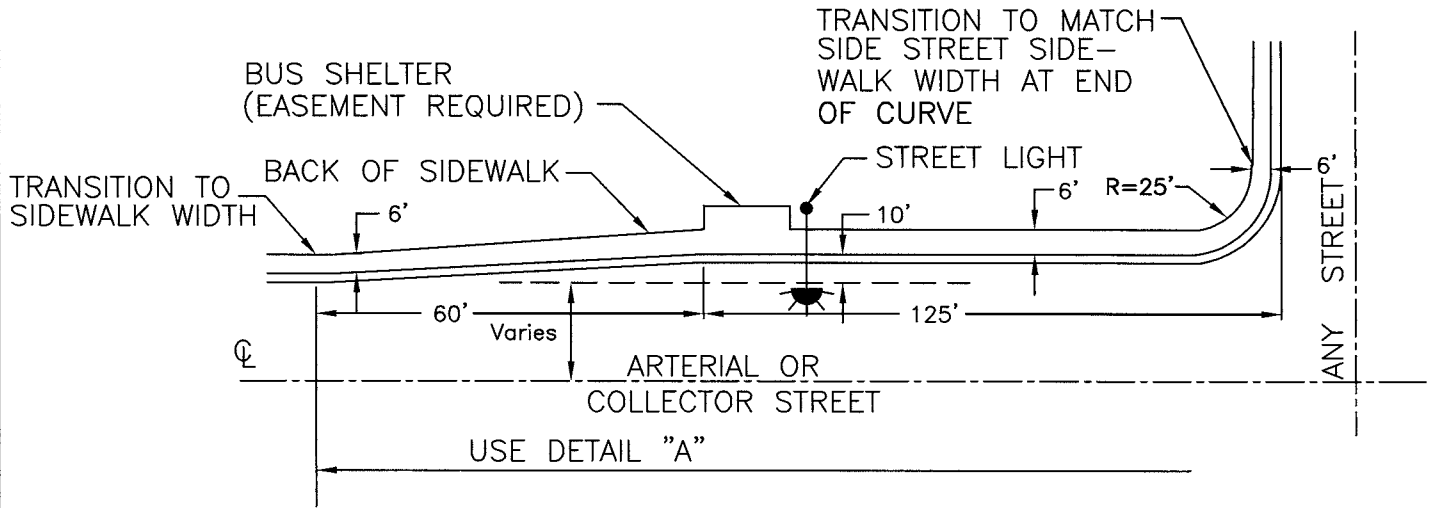

**BUS TURNOUT AT CORNER**

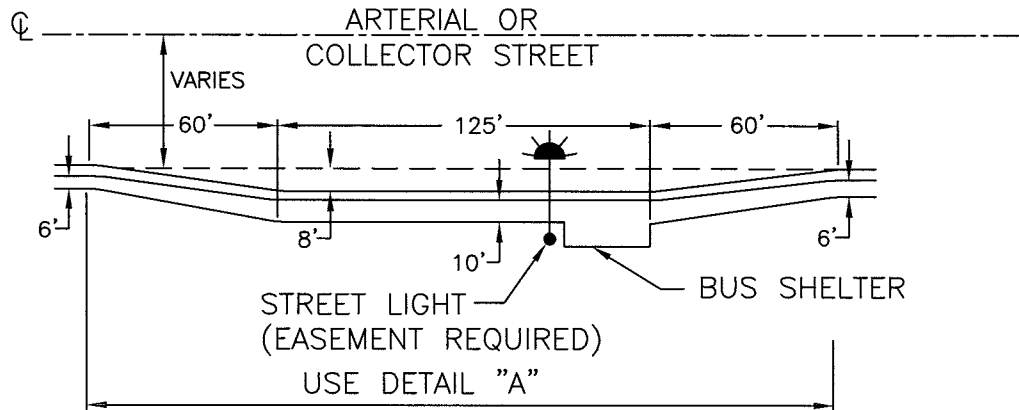

**TYPICAL MID-BLOCK BUS TURNOUT**

**NOTES:**

1. THE DIMENSIONS SHOWN ARE MINIMUM STANDARDS. THE COUNTY ENGINEER MAY DETERMINE ADDITIONAL WIDENING TO BE NECESSARY, WHERE HIGHER OPERATING SPEEDS AND TRAFFIC VOLUMES ARE ANTICIPATED.
2. ON ARTERIALS, SIDEWALKS MAY BE ADJACENT TO CURB IN RETROFIT SITUATIONS ONLY. ALL NEW CONSTRUCTION REQUIRES SEPARATED SIDEWALKS PER STANDARDS.

<b>COUNTY OF YOLO</b>		DATE:
PLANNING AND PUBLIC WORKS DEPARTMENT		08/05/08
<b>BUS TURNOUT</b>		SHEET #
		2 OF 3
<i>Panos Kolkas</i>		DRAWING #:
COUNTY ENGINEER No. C42401	28 AUG 08	4-29
	APPROVAL DATE	NOT TO SCALE



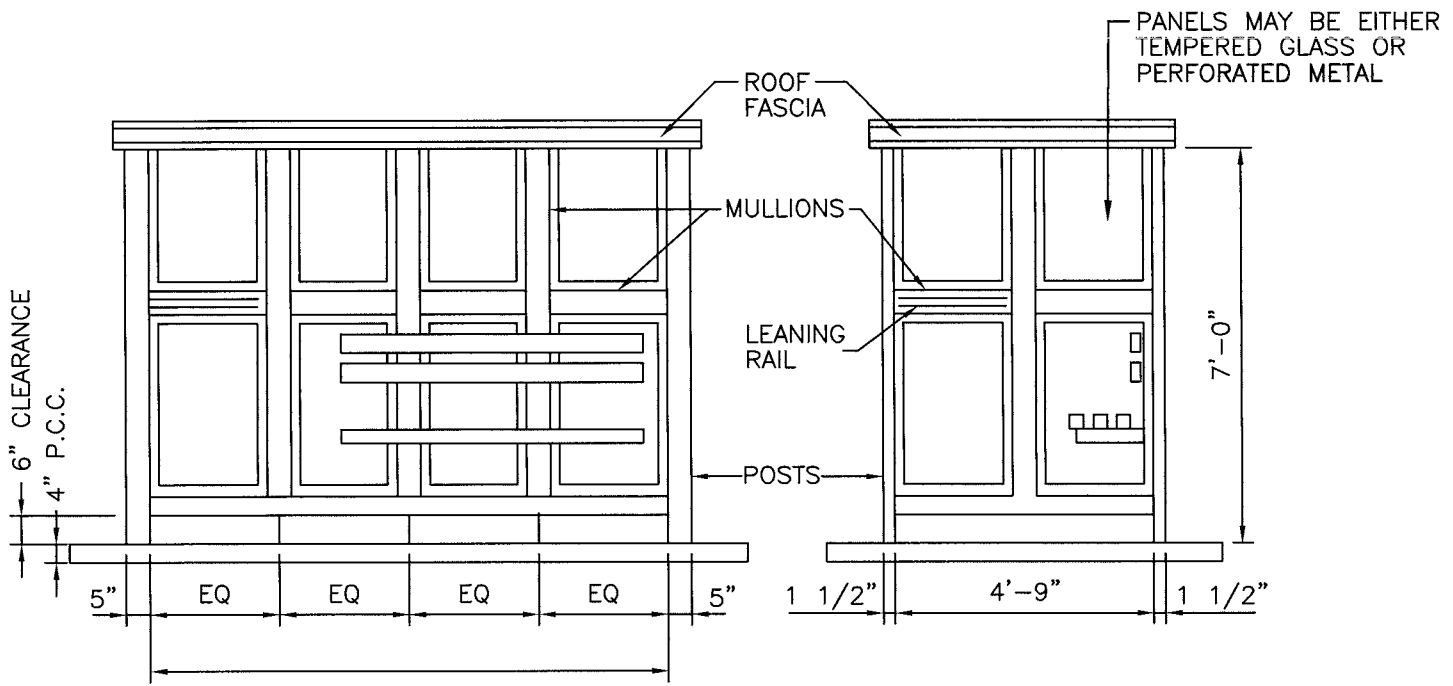

**BUS SHELTER DESIGN**

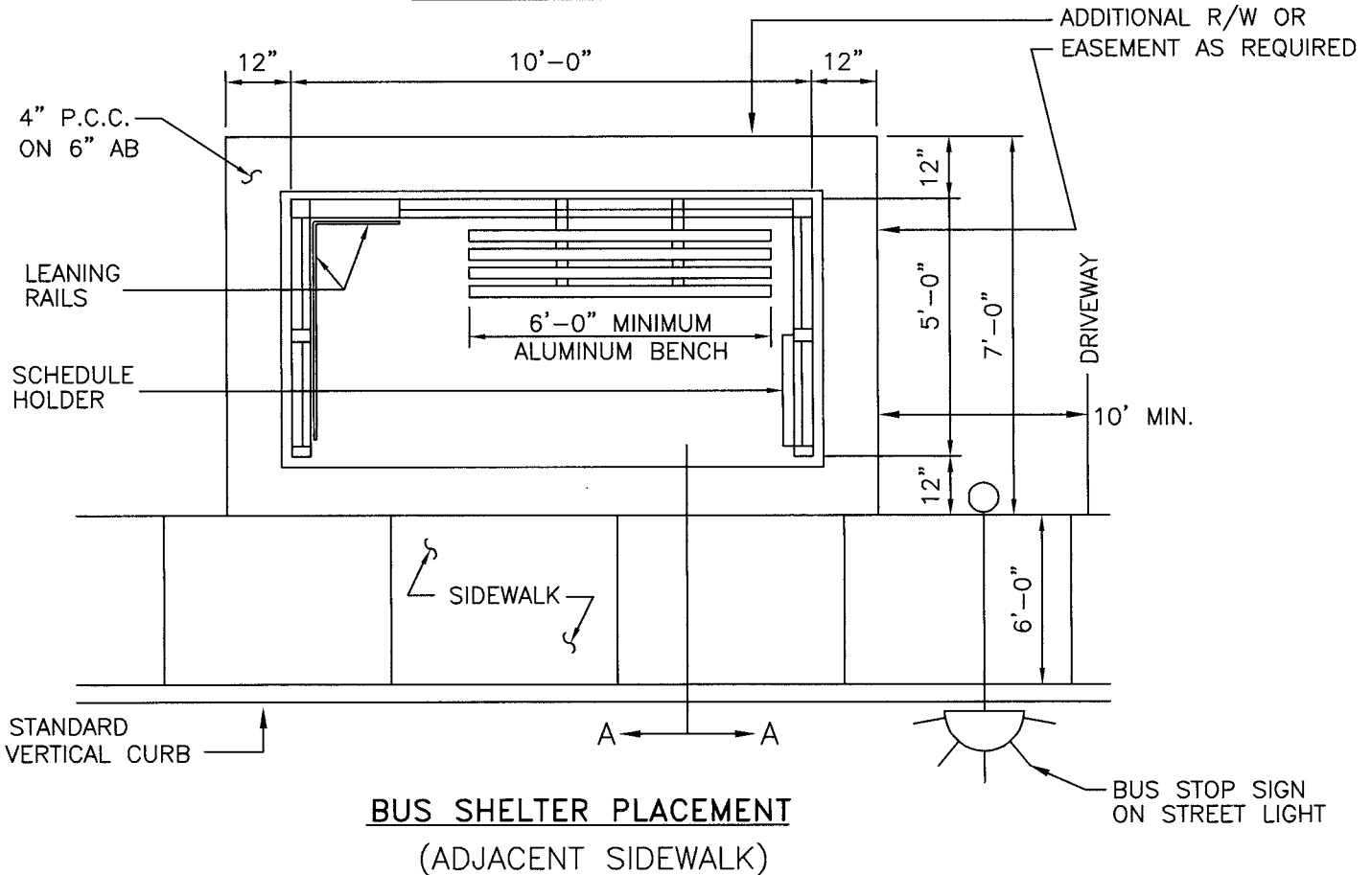

**BUS SHELTER PLACEMENT  
(ADJACENT SIDEWALK)**

**NOTE:**

- BUS SHELTER SHALL BE APPROVED BY YOLO COUNTY TRANSPORTATION DISTRICT.

<b>COUNTY OF YOLO</b> PLANNING AND PUBLIC WORKS DEPARTMENT		DATE: 08/05/08
<b>BUS SHELTER DESIGN AND PLACEMENT</b>		SHEET # 3 OF 3
<i>Parvinder Kothla</i> COUNTY ENGINEER No. C42401		DRAWING #: <b>4-29</b> NOT TO SCALE
28 AUG - 08 APPROVAL DATE		

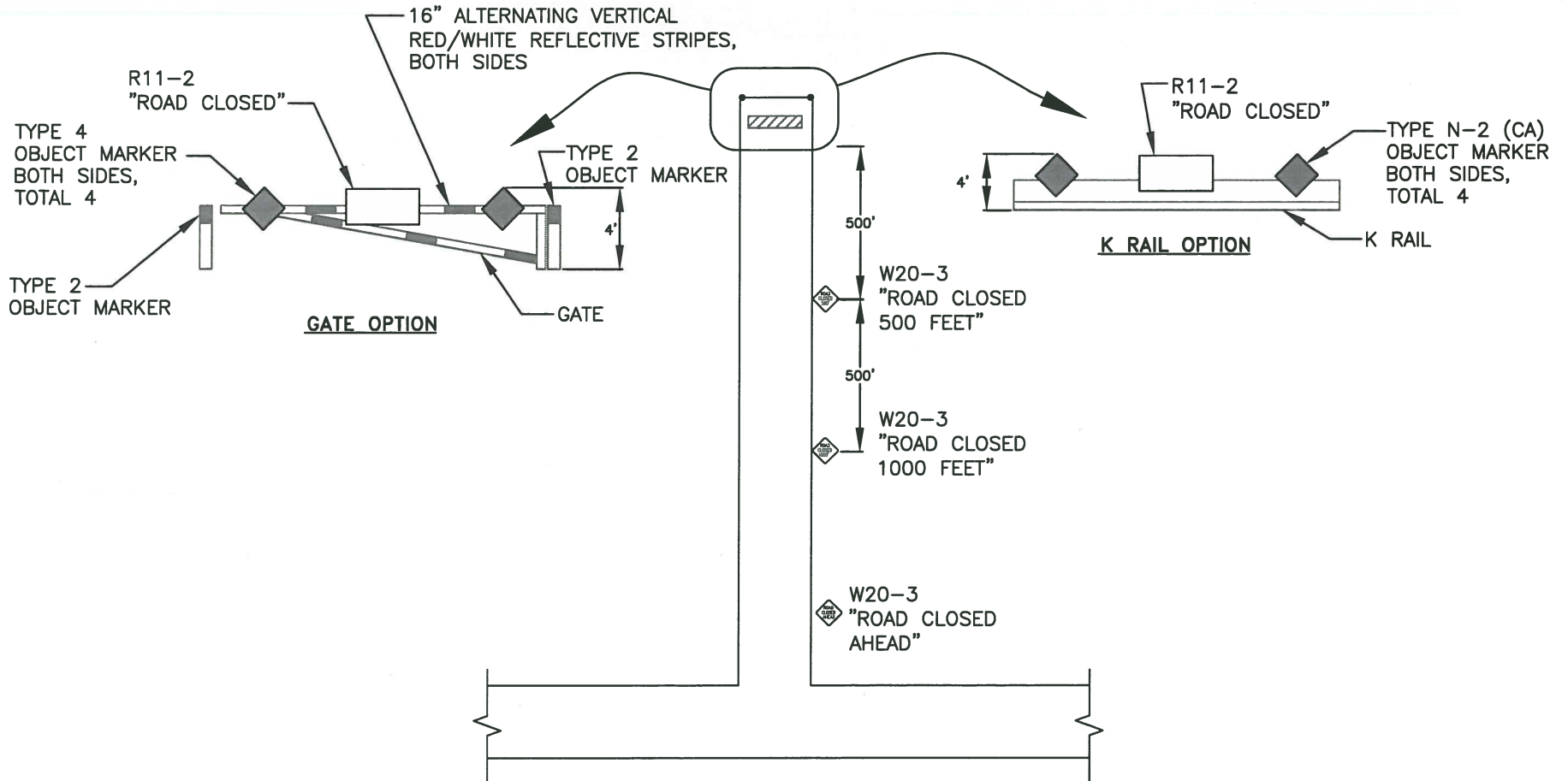

**TYPICAL ROAD CLOSURE PLAN**

NTS

**NOTES:**

1. PLACE FIRST "ROAD CLOSED AHEAD" SIGN AT NEAREST INTERSECTING ROAD.
2. R11-2 "ROAD CLOSED" AND N-2(CA) MAY BE MOUNTED ON K-RAIL, A GATE, OR TYPE III BARRICADES WITH SANDBAG BALLASTS.
3. CLOSURE SHALL BE IMPLEMENTED ON BOTH APPROACHES TO CLOSED ROAD SEGMENT.
4. WHEN KEEPER POST IS PROVIDED TO ALLOW GATE TO REMAIN IN OPEN POSITION, GATE ARM SHALL BE ROTATED TO THE DOWNSTREAM DIRECTION.

<b>COUNTY OF YOLO</b> PUBLIC WORKS DIVISION		DATE: 11/21/17
<b>TEMPORARY ROAD CLOSURE</b>		SHEET # 1 OF 1
<i>Paras Katta</i> COUNTY ENGINEER No. C42401		APPROVAL DATE 13 DEC. 2017
		DRAWING #: <b>4-30</b> NOT TO SCALE

**SECTION 5**

**STREET LIGHTING AND TELECOMMUNICATIONS DETAILS**

<b><u>CONTENTS</u></b>	<b><u>Page</u></b>
5-1 Street Lights Required.....	5-1
5-2 Street Lights on Private Roadways .....	5-1
5-3 Developer’s Responsibility .....	5-1
5-4 Utility Company Authorization.....	5-1
5-5 General Plan Details .....	5-1
5-6 Design Standards .....	5-2
5-7 Street Light Design Details .....	5-4
5-8 Master Planning.....	5-6

## **SECTION 5 STREET LIGHTING AND TELECOMMUNICATIONS DETAILS**

### **5-1 STREET LIGHTS REQUIRED**

Streetlights shall be provided on all public streets. Streetlights may be required adjacent to parcels containing structures which are being improved or altered, depending on the nature and extent of the work. Illustrations of streetlights generally required are shown on Standard Drawing 5-1 and 5-2.

### **5-2 STREET LIGHTS ON PRIVATE ROADWAYS**

Streetlights may be required on private roadways serving more than 4 residences or serving a commercial use, as determined by the County Engineer. For planned developments, residential, commercial, and industrial developments where the internal streets are private, a private street lighting system will be required for the internal non-dedicated streets, in addition to public street lighting provided by the Developer on the external public street frontage.

### **5-3 DEVELOPER'S RESPONSIBILITY**

Existing streetlights which must be relocated or repositioned as a result of the construction of new streets or driveways into a development shall be the responsibility of the Developer.

A new service can with a step-down transformer, required as a result of the modification, replacement or relocation of an existing utility service pedestal shall be the responsibility of the Developer.

It shall be the responsibility of the Developer to ensure that the existing street light system remains operational until the new street light system to replace it is completed and functioning correctly.

The Developer shall coordinate with electric utility for planning, design, preparation of plans, financing (pay all fees and costs) and operation, as required to install new streetlights. The Developer shall submit joint trench utility plans to the County showing the installation of streetlights.

All streetlights will be publicly owned (by County or Community Service District) and maintained by the electric utility via standard LS-series rate charges. Any existing private streetlight to be relocated as part of the project shall be converted to a publicly owned light. In certain limited cases, the lights may be owned and maintained by the electric utility, as directed by the County Engineer.

### **5-4 UTILITY COMPANY AUTHORIZATION**

A written notice from the serving utility company, stating that line clearance and service have been checked and that the street lighting design meets utility standards and will be served by the utility, shall be submitted to the County Engineer for all developments.

### **5-5 GENERAL PLAN DETAILS**

The plans shall show and identify all street lights to be installed, all existing lights in the immediate vicinity of the project, all conduit and conductor runs, service points, trees, and all applicable provisions and details specified in these standards.

On subdivision projects, a separate plan sheet shall be included for the street lighting system. This plan sheet may be combined with a signage plan. In addition, joint trench composite plans shall be submitted. Street lights (exclusive of other required information) shall also be shown on street plan and profile sheets. In addition to the above, the following shall be required on the street light portion of subdivision plans, even though duplications may be involved:

- All details of street light construction.
- A signature block conforming to Standard Drawing 3-2.
- Utility lines and public utility easements.
- Names of adjacent subdivisions.
- Intersecting property lines of adjacent properties.
- Legend indicating electrical symbols.
- A North arrow and appropriate scale. (1" = 10' to 1" = 100')
- All existing street lights on both sides of any streets.
- All new tree installations shall be more than 10' from street lights.
- All trees within the vicinity of the conduit runs or proposed streetlights.
- Street lights shall be located at least 15 feet away from any fire hydrant.

#### **5-6 DESIGN STANDARDS**

- A. Street lighting shall be designed in conformance with the "American National Standard Practice for Roadway Lighting" of the American National Standards Institute (ANSI/IESNA RP-8). The following table may be used as guidance for small projects, as determined by the County Engineer.

<b>TABLE 5-1 STREET LIGHTING GUIDE</b>						
<b>Street Classification</b>	<b>Width</b> (Feet at Face of Curb)	<b>Typical Pole Height</b> (Feet)	<b>High Pressure Sodium Lamp</b> (Watts)	<b>Distribution Type</b>	<b>Typical Spacing<sup>1</sup></b> (Feet)	<b>Maintained Illuminance</b> (Ft. Candles)
<b>Local Residential, Local Residential Low-Volume, Primary Residential</b>	32-40	25	70	II mid-block III intersections	200-250	.47
<b>Collector</b>	40-64	30	100	III	200-250	.87
<b>Industrial</b>	48-64	30	100	III	200-250	.41
<b>Arterial (2-lane)</b>	54	30	100	III	150-200 <sup>2</sup>	1.07
<b>Arterial (4-lane)</b>	78	30	150	III	150-175 <sup>2</sup>	1.11
<b>Bike Path</b>	10	15	70	II	115 <sup>3</sup>	.17
<b>Open Space</b>	-	14 to 20	70	III, IV or V	Note 4	.17

Note 1: Standard “Cobra” style with 8’ mast arm. Post top style requires review of illuminance based layout.  
 Note 2: Lights mounted back to back on single pole in median.  
 Note 3: Standard post top style along bike paths.  
 Note 4: Calculations to be performed by the lighting designer.

- B.** Data and calculations indicating compliance shall be submitted for review, when required by the County Engineer. The electrical system shall be designed for 120 volts single phase. In special circumstances, the design voltage may be increased to 240 volts. Voltages higher than 240 will not be allowed. Electronic copies of light photometric distribution patterns shall be provided for any non-standard lights.
- C.** Lumens used to calculate the Average Illuminance shall be based on 80% of the manufacturer’s value for the lamp. The luminaire depreciation factor (dirt accumulation) shall be 60%.
- D.** Lamps other than High Pressure Sodium are not allowed.
- E.** Light Spacing may be adjusted ±10% to allow for driveways and other physical obstacles.
- F.** Open space design criteria shall be reviewed and approved by the County Engineer on a case by case basis.
- G.** Provide luminosity plan.
- H.** Provide shields on house-side of luminaire.

**5-7 STREET LIGHT DESIGN DETAILS**

- A.** Intersections: Intersections shall have at least one streetlight. Intersection street light locations and the number required shall conform to Standard Drawings 5-3 and 5-4.
- B.** Cul-de-sacs: All cul-de-sacs exceeding 130 feet in length, measured from the street light location at the intersection to the right-of-way line at the end of the cul-de-sac, shall have a street light within the bulb. The location of the streetlight within the bulb shall conform to Standard Drawing 5-4.
- C.** Bike Paths: Streetlights shall be placed as indicated in the Street Lighting Guide table, and at both ends.
- D.** Spacing: The maximum street light spacing, measured along the street centerline, shall conform to the above table. Streetlights on arterial streets shall be staggered. Double median poles will be considered on a case-by-case basis and require special approval.
- E.** Street Light Poles: All street light poles shall be of galvanized steel, aluminum or concrete, as required to match nearby facilities. Poles shall be identified on the plans or in the special provisions. Identification information shall include material type, bolt circle diameter, luminaire mounting height, pole dimensions and length of mast arm.

The County Engineer may approve special or unusual designs if warranted by the character of the surrounding neighborhood. Where special or unusual design street light poles are not listed in the Caltrans Standard Specifications, the Developer shall supply additional poles to the County for future pole replacement. The minimum number of replacement poles to be supplied to the County shall be 10% of the poles being installed with any fractional percent rounded up to the next whole number.

The position of the street light poles relative to sidewalk shall conform to Standard Drawing 5-5.

- F.** Street Lights on Existing Utility-Owned Poles: When there are permanent existing utility owned poles with existing streetlights adjacent to the project, the existing streetlights shall be replaced with publicly owned streetlights in accordance with these standards. The Developer shall make all arrangements with the owning utility for disconnection and removal of existing pole mounted streetlights.
- G.** Luminaires and Ballasts:
1. Luminaires shall be high-pressure sodium type with internal ballasts. The type of street light and the appropriate wattage shall be specified on the plans. All luminaires shall conform to the standards outlined in the Caltrans Standard Specifications; light distribution shall be ANSI type II or III per these design standards and shall be full cut-off type unless specified otherwise by the County Engineer. The light pattern for each luminaire shall be specified on the plans.
  2. Ballasts shall conform to the standards outlined in the Caltrans Standard Specifications, except that for 70 and 100-watt high-pressure sodium luminaires the ballast shall be energy efficient.
- H.** Service: All street light systems shall have underground service provided. Service points shall be provided within a utility easement immediately adjacent to or within the right-of-way and shall be open and easily accessible to the street frontage. Types of service are as follows:
1. A direct underground service consists of one light being served from a single service point. Whenever possible, new lights on developments adjacent to existing development

shall connect to an existing service point. The service point may be in the form of a pullbox or a service pedestal installed by the Developer. See Standard Drawings 5-6 and 5-7 for design details.

2. Multiple service is two or more lights being served from a single service point installed by the Developer. The service point shall be a pullbox. Multiple systems shall have a service pedestal normally located adjacent to the PG&E service point. The service pedestal shall be a Caltrans Type III-AF, stainless steel cabinet.
  3. The County Engineer may approve overhead service in unusual areas where it cannot be provided underground. The Developer's Design Engineer shall be responsible for all electrical details and modifications to the standards relating to overhead service.
- I.** Pullboxes: All pullboxes, including the size, shall be shown and identified on the plans. Pullboxes shall be installed adjacent to all street lights, at junction points of conduit runs, and when distance between pull boxes exceeds 200 feet long. The standard pull box shall be a Caltrans #3½, with the cover labeled "Street Lighting", and shall be located at least 20 feet from any fire hydrant.
- J.** Conductors: All conductors, including quantity and size, shall be identified on the plans. Unless otherwise specified, conductors shall be single conductor, solid or stranded copper, sized in accordance with these standards and the National Electrical Code.
1. On a direct underground service, the minimum conductor shall be No. 8 A.W.G. In general, conductors larger than No. 2 A.W.G. will not be allowed.
  2. On multiple services, the minimum conductor size from the service point to the service shall be No. 8 A.W.G.
  3. The size of each conductor from the service point to the luminaires shall be such that the voltage drop along each circuit will not exceed 7% for 2-wire systems and 6% for 3-wire systems of the nominal service voltage to the farthest luminaire. The nominal service voltage to be used in the voltage drop calculations shall be 115 volts. Calculations shall be submitted substantiating the design criteria for every circuit, including the total load in amperes of each circuit at the service can.
  4. The lamp amperage (or power demand) shall be based on total lamp wattage, including any losses in the ballast or other electrical components of the luminaire.
  5. Where only one photocell is required in a multiple service system, it shall be connected to the service can with three No. 14 A.W.G. conductors.
- K.** Photo Cell: A single photocell receptacle shall be provided on the luminaire nearest to the service point for multiple service containing four or more lights. All other light systems shall have a photocell in each luminaire.
- L.** Conduit: All conduit runs, including the size, shall be shown and identified on the plans. The minimum size for new conduits is one-and-one-half-inch (1½") diameter conduit. Minimum cover shall be 24 inches to finished ground in landscaped areas and 30 inches in roadway areas.
- For a system designed using the 3-wire system, only 2 circuits (one set of 3 wires) shall be allowed in any conduit. Circuits based on the 2-wire system and the 3-wire system shall not be mixed in any conduit. All circuits may, however, be mixed in the same conduit from the service can to the first pull box.



The design may include more than two circuits in a conduit if the conductors for each circuit (2-wire) or set of circuits (3-wire) are identified by conductor insulation which is a solid color or a basic color with a permanent colored stripe. The identification stripe shall be continuous over the entire length of the conductor.

New development shall install one-and-one-half-inch (1½") conduit, or larger as required, with one No. 10 A.W.G. stranded pullwire from the last light on each end of the system to the adjacent property line, where the adjacent property has no existing street lighting system.

- M.** Electrical Equipment and Work: Control and switching equipment and fusing of all circuits shall meet the requirements of the National Electrical Code, the Basic Electrical Regulations, Title 24, Part 3, of the California Administrative Code, the rules of the National Board of Fire Underwriters, and Yolo County.

## **5-8 MASTER PLANNING**

Master planning is the determination of street light locations between control points. Control points are proposed street light locations at street intersections in accordance with the above sections and Standard Drawings 5-3 and 5-4, and existing streetlights. The purpose of master planning is to establish an overall uniform street light system that meets minimum requirements. Master planning shall apply to both sides of the street. The procedure is outlined as follows:

- A.** Identify the nearest intersections each way from the street light locations being planned. Determine the location of the streetlights at the intersections in conformance with the design standards in the above sections.
- B.** Identify any existing street lights situated between the intersections.
- C.** Determine the distance between the adjacent designed intersection streetlights and/or adjacent existing streetlights, whichever are nearest to the street light locations being planned.
- D.** Divide the distance into equal spaces between lights not to exceed the maximum spacing requirements specified in the above sections.
- E.** Compare the light locations to intersecting property lines, driveways, pedestrian lanes, and other obstructions as follows:
  1. If the location falls close to a property line and it can be adjusted to the property line while staying within the maximum spacing allowed, then the adjustment should be made.
  2. Generally, streetlights should be situated at intersecting property lines for residential lots and parcels with minimal frontage (75 feet or less). The light spacing may have to be unbalanced, with additional lights being added to attain this and still comply with the maximum spacing allowed.
  3. Street light locations shall be adjusted to miss driveways, mailboxes, utility boxes, and other obstructions by five feet, and shall be located at least 20 feet from any fire hydrant.
- F.** Street light locations on arterial streets should be adjusted, when possible, to obtain a more uniform light distribution if there are existing street lights on the opposite side of the street.

<b>Standard Drawings</b>		
<b>Section 5 – Street Lighting and Telecommunications Details</b>		
<b>Drawing</b>	<b>Sheets</b>	<b>Description</b>
5-1	1	Standard Street Light and Legend
5-2	1	Post Top Street Light
5-3	1	Typical Street Light Locations, Arterial Streets
5-4	1	Typical Street Light Locations, Collector and Residential Streets
5-5	1	Base Location for Street Light
5-6	1	Single Light Direct Service
5-7	1	Service Point Pull Box
5-8	1	Electric Service Pedestal
IT-1	1	Standard Cable Trench Sections
IT-2	1	Fiber Optics & Signal Interconnect Pull Boxes
IT-3	1	4' X 7' Vault Detail 1
IT-4	1	4' X 7' Vault Detail 2
IT-5	1	3' X 5' Vault Detail 1
IT-6	1	3' X 5' Vault Detail 2
IT-7	1	Fiber Optic Conduit Handhole Entry
IT-8	1	Typical Fiber Optic Conduit Sweep Detail

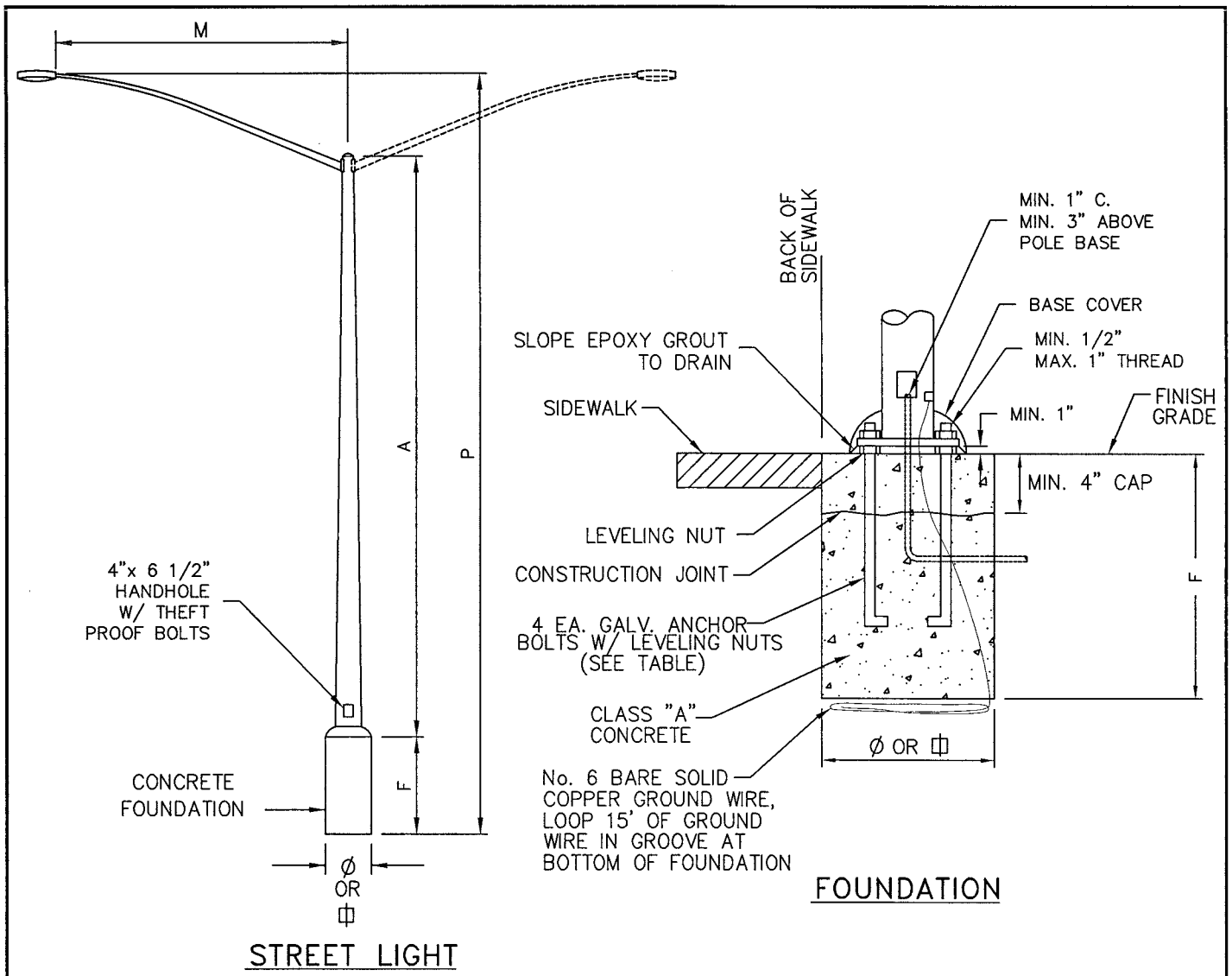

POLE DATA			ARM	FOUNDATION		ANCHOR BOLTS		
A HEIGHT	P MTG. HGT.	ACCEPTABLE PRODUCTS	M LENGTH	F DEPTH	phi DIA	square SQ	SIZE	BOLT CIRCLE
22'-6"	25'-0"	VALAMONT DS 50 5.9A220-6S OR APPROVED EQUIVALENT	6'	3'-4"	24"	20"	1" x 36" x 4"	9"
27'-6"	30'-0"	VALAMONT DS 50 6.6A270-6S OR APPROVED EQUIVALENT	6'	5'-0"	30"	27"	1" x 36" x 4"	9 1/2"

**NOTES:**

- PULL BOX SHALL BE INSTALLED ADJACENT TO POLE WITHIN 36". PULL BOX SHALL NOT BE LOCATED IN SIDEWALK WITHOUT PRIOR APPROVAL OF THE COUNTY ENGINEER.
- WHEN A SECONDARY PULL BOX IS LOCATED WITHIN 8' OF POLE, PULL BOX AT BASE OF STREETLIGHT IS NOT REQUIRED.
- COMPLY WITH ALL UTILITY REQUIREMENTS.
- STREET LIGHT NUMBERING SHALL BE AS REQUIRED BY PACIFIC GAS AND ELECTRIC (UTILITY).
- PROVIDE SHIELDS ON HOUSE SIDE.

**LEGEND**

PROPOSED	EXISTING	
		STANDARD STREET LIGHT
		POST TOP
		PULLBOX
		CONDUIT
		SERVICE CAN
		U.G. UTILITY SERVICE PEDESTAL
		TRANSFORMER
		WOOD POLE

<b>COUNTY OF YOLO</b>		DATE: 08/05/08
PLANNING AND PUBLIC WORKS DEPARTMENT		SHEET # 1 OF 1
<b>STANDARD STREET LIGHT AND LEGEND</b>		DRAWING #: 5-1 NOT TO SCALE
 COUNTY ENGINEER No. C42401		28 AUG 08 APPROVAL DATE

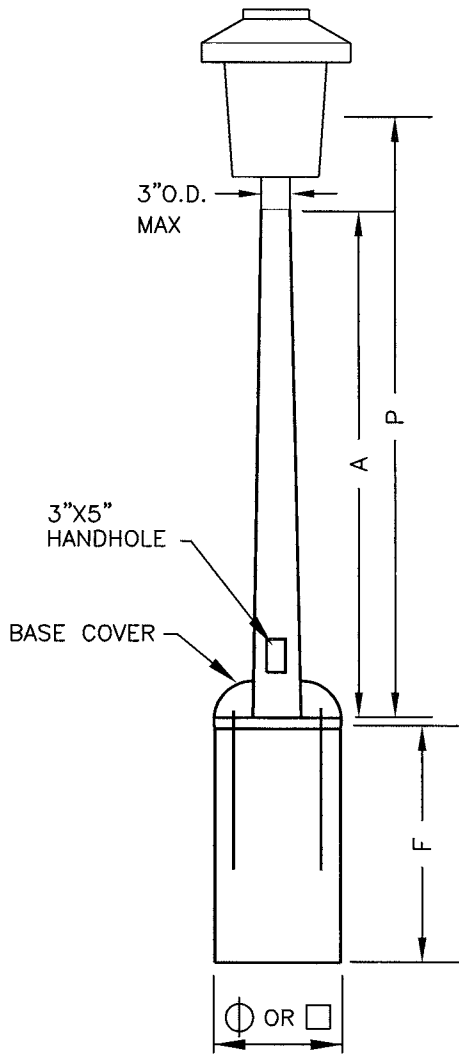

**POST TOP LIGHT**

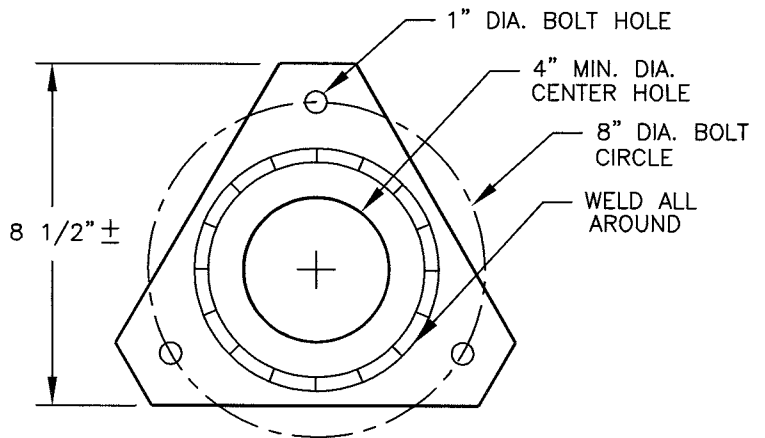
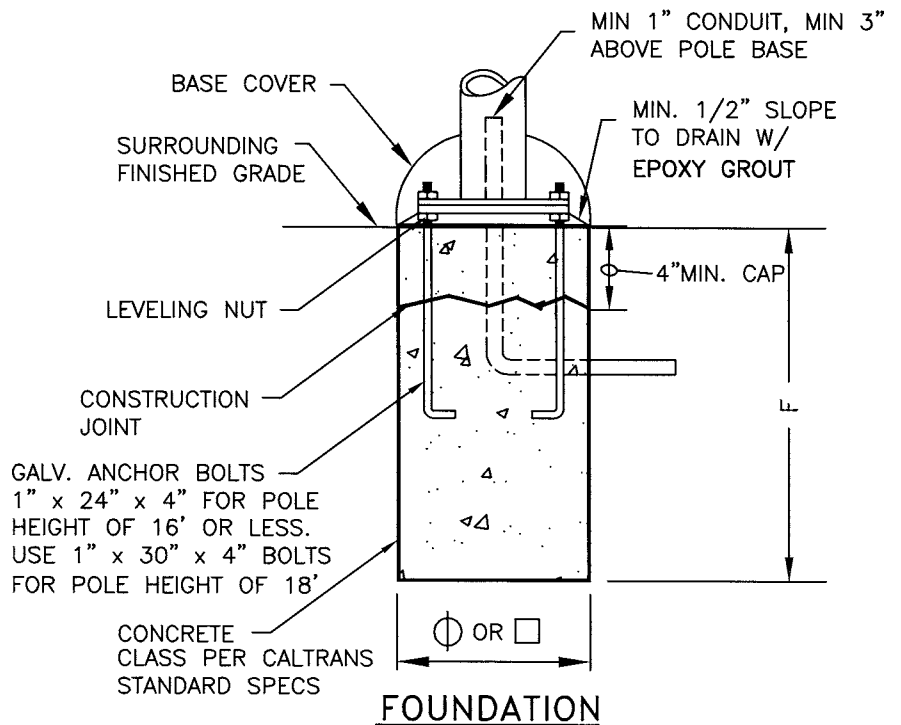

**BASE**

POLE DATA			FOUNDATION		
A HEIGHT	P MTG. HGT.	ACCEPTABLE PRODUCTS	F DEPTH	Ø DIA.	□ SQ.
12', 14', 16'	VARIABLES	UNION METAL DESIGN SERIES 201 AMERON SERIES PGF VALMONT SERIES DS 200 OR APPROVED EQUIVALENT	30"	27"	24"
18'	VARIABLES		36"	27"	24"

**NOTES:**

1. REFER TO UTILITY REQUIREMENTS FOR CONDUITS, WIRING AND GROUNDING.

<b>COUNTY OF YOLO</b>		DATE:
PLANNING AND PUBLIC WORKS DEPARTMENT		08/05/08
<b>POST TOP STREET LIGHT</b>		SHEET #
		1 OF 1
<i>Paros Kokkas</i>		DRAWING #:
COUNTY ENGINEER No. C42401		5-2
28 AUG. 08		NOT TO SCALE
APPROVAL DATE		

# STREET LIGHT PLACEMENT ARTERIAL STREETS

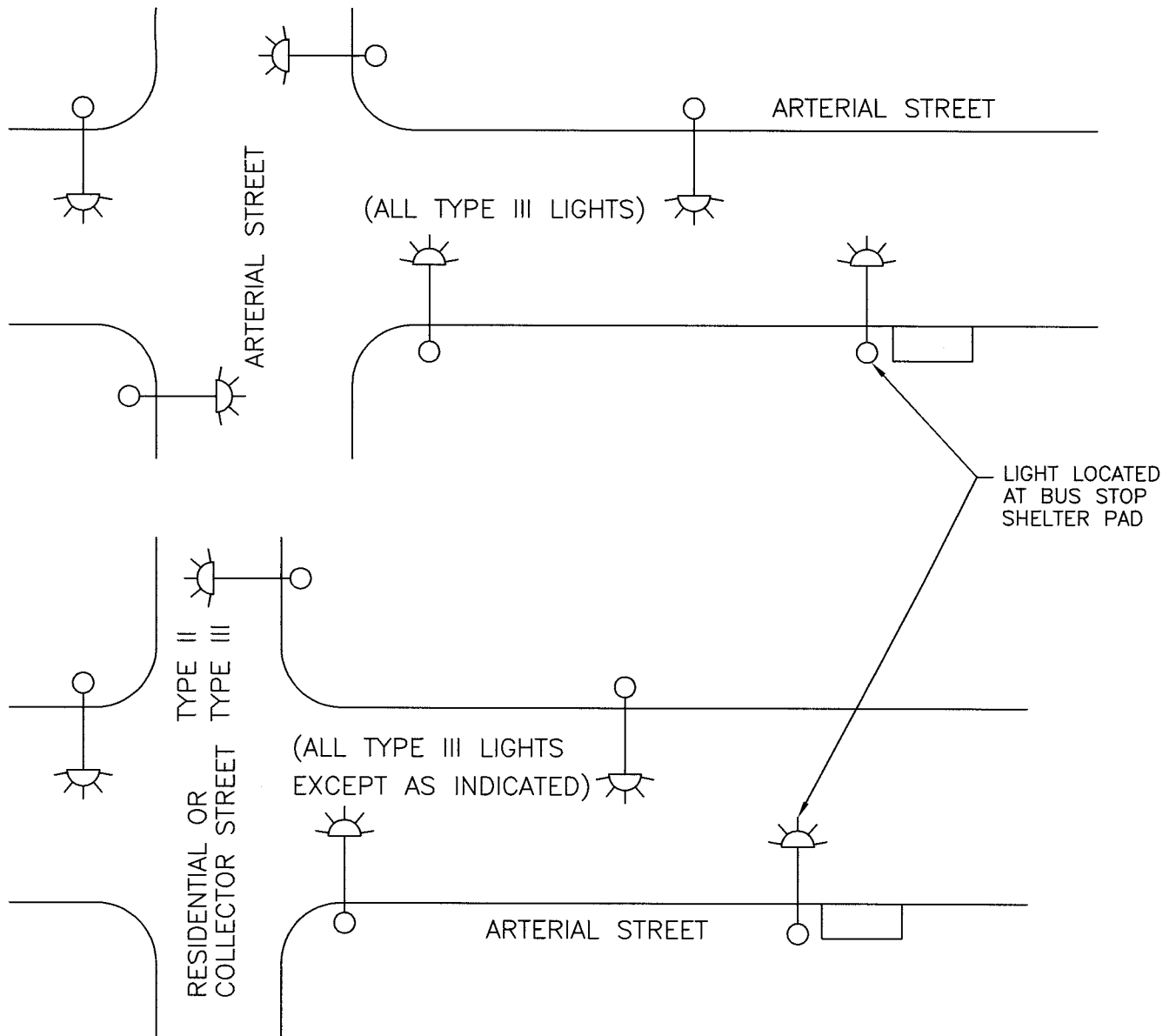

**NOTE:**

1. SEE SECTION 5-6 OF THE SPECIFICATIONS FOR STREET LIGHT SPACING.

<b>COUNTY OF YOLO</b> PLANNING AND PUBLIC WORKS DEPARTMENT		DATE: 08/05/08
<b>TYPICAL STREET LIGHT LOCATIONS</b> <b>ARTERIAL STREETS</b>		SHEET # 1 OF 1
<i>Paros Kallas</i> COUNTY ENGINEER No. C42401	28 AUG. 08 APPROVAL DATE	DRAWING #: <b>5-3</b> NOT TO SCALE

# STREET LIGHT PLACEMENT ON COLLECTOR AND RESIDENTIAL STREETS

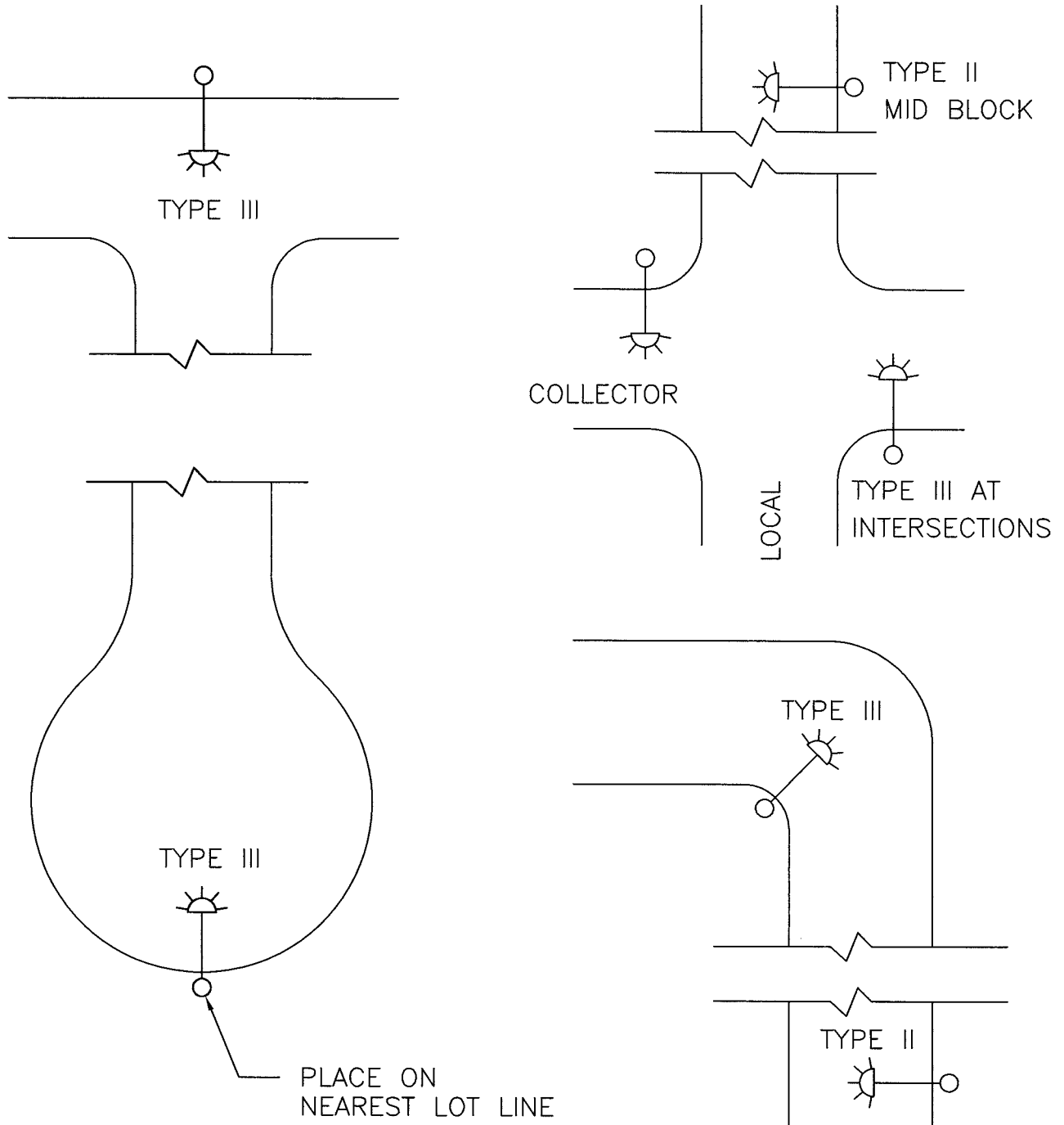

<b>COUNTY OF YOLO</b>		DATE:
PLANNING AND PUBLIC WORKS DEPARTMENT		08/05/08
<b>TYPICAL STREET LIGHT LOCATIONS</b>		SHEET #
<b>COLLECTOR AND RESIDENTIAL STREETS</b>		1 OF 1
<i>Paros Kalkas</i>	<i>28 AUG 08</i>	DRAWING #:
COUNTY ENGINEER No. C42401	APPROVAL DATE	5-4
		NOT TO SCALE

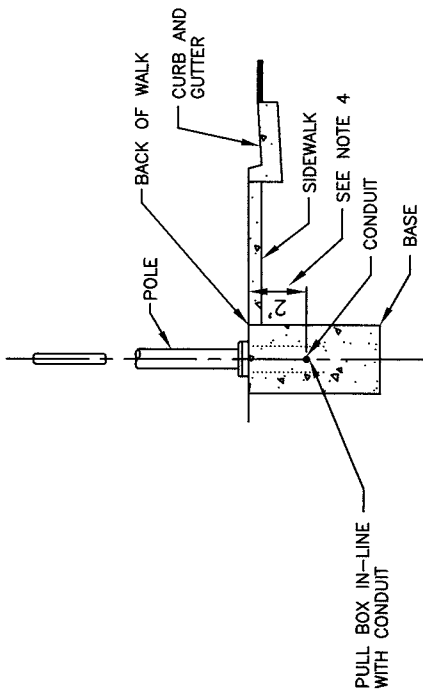

**SECTION B-B**

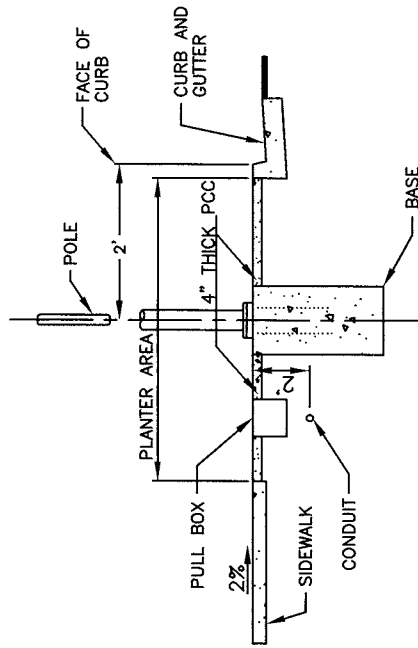

**SECTION A-A**

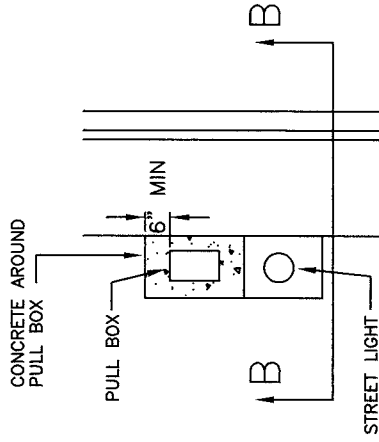

**PLAN-STREET LIGHT AT CURB GUTTER AND SIDEWALK**

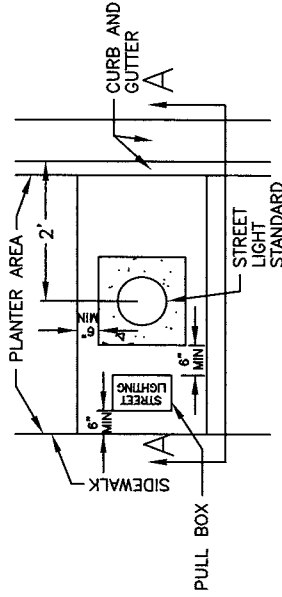

**PLAN-STREET LIGHT AT PLANTER STRIP**

**NOTES:**

1. CONDUIT TRENCH BACKFILL SHALL BE COMPACTED TO 95% RELATIVE COMPACTION.
2. LANDSCAPING GRADES IN THE AREA OF THE STREET LIGHT STANDARD WILL MATCH BASE ELEVATION. SEE SHEET 5-7 FOR STREET LIGHT SERVICE POINT PULL BOX DETAILS.
3. INSTALL RODENT SCREEN AT THE BOTTOM OF THE PULL BOX.
4. IF CONDUIT IS LOCATED BENEATH THE SIDEWALK, IT MAY BE PLACED AT 18" DEPTH INSTEAD OF 2'.
5. PULL BOX MAY BE OMITTED IF SERVICE PT IS WITHIN 50' OF LIGHT.
6. PRECAST BASES MAY BE USED, BUT MUST BE BACKFILLED WITH 2-SACK CONCRETE SLURRY VIBRATED INTO PLACE.
7. PROVIDE SHIELD ON HOUSE SIDE.

COUNTY OF YOLO		DATE: 08/05/08
PLANNING AND PUBLIC WORKS DEPARTMENT		SHEET # 1 OF 1
BASE LOCATION FOR STREET LIGHT		DRAWING #: 5-5
<i>Ranias Kollas</i> COUNTY ENGINEER No. C42401		APPROVAL DATE: 28 Aug. 08
NOT TO SCALE		

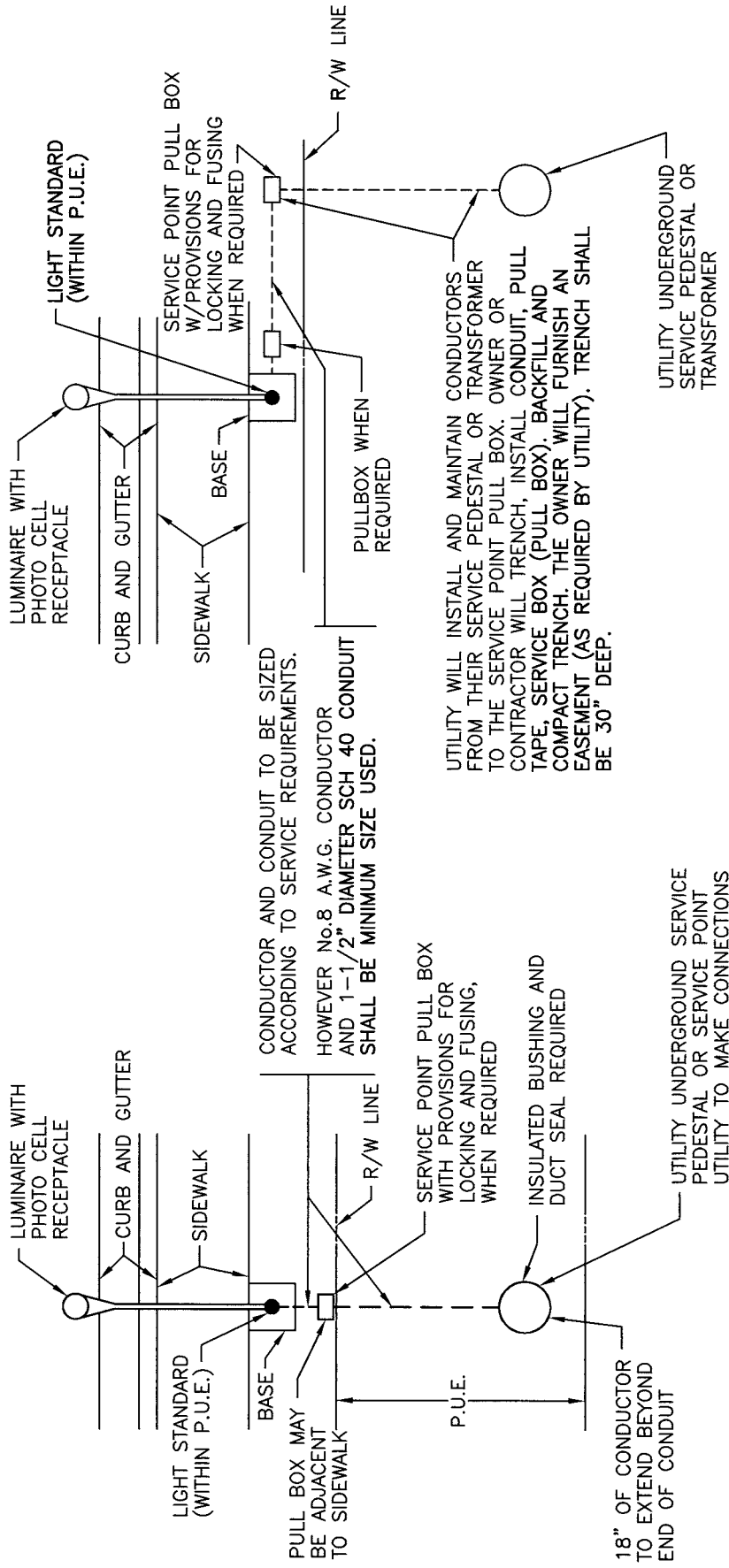

**NOTES:**

1. CONNECT NEUTRAL CONDUCTOR TO GROUNDING ELECTRODE IN SERVICE POINT PULL BOX.
2. ALL FACILITIES SHALL BE WITHIN RIGHT-OF-WAY OR PUBLIC UTILITY EASEMENT.
3. CONDUIT TO TERMINATE 2" BELOW BOTTOM OF HANDHOLE.
4. SEE SHEET 5-7 FOR STREET LIGHT SERVICE POINT PULL BOX DETAILS.

RESIDENTIAL SERVICE

COMMERCIAL SERVICE

PLANNING AND PUBLIC WORKS DEPARTMENT	COUNTY OF YOLO	DATE: 08/05/08
SINGLE LIGHT		SHEET # 1 OF 1
DIRECT SERVICE		DRAWING #: 5-6
<i>James Walker</i> COUNTY ENGINEER No. C42401	<i>28 Aug. 08</i> APPROVAL DATE	NOT TO SCALE



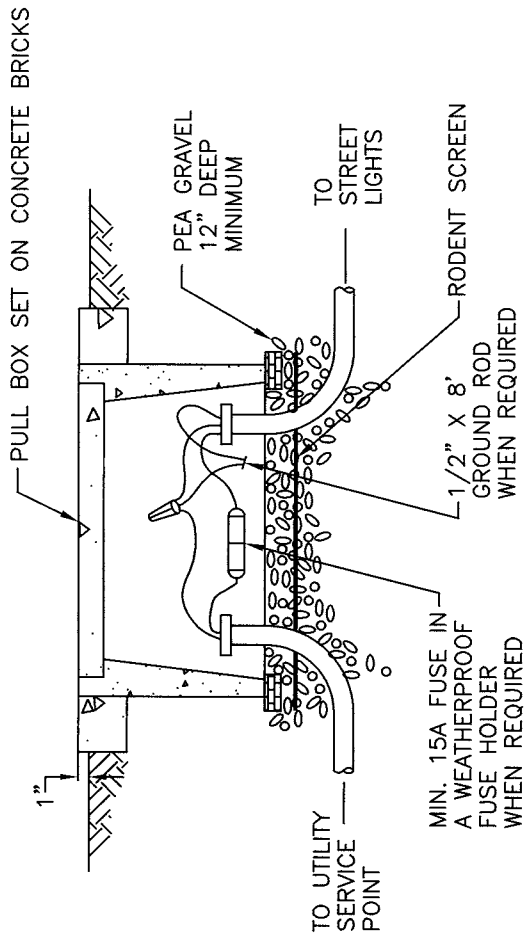

LAMP WATTAGE	FUSE SIZE
200 WATT OR LESS	6 AMP
250 WATT-400 WATT	10 AMP

### SERVICE POINT PULL BOX DETAILS

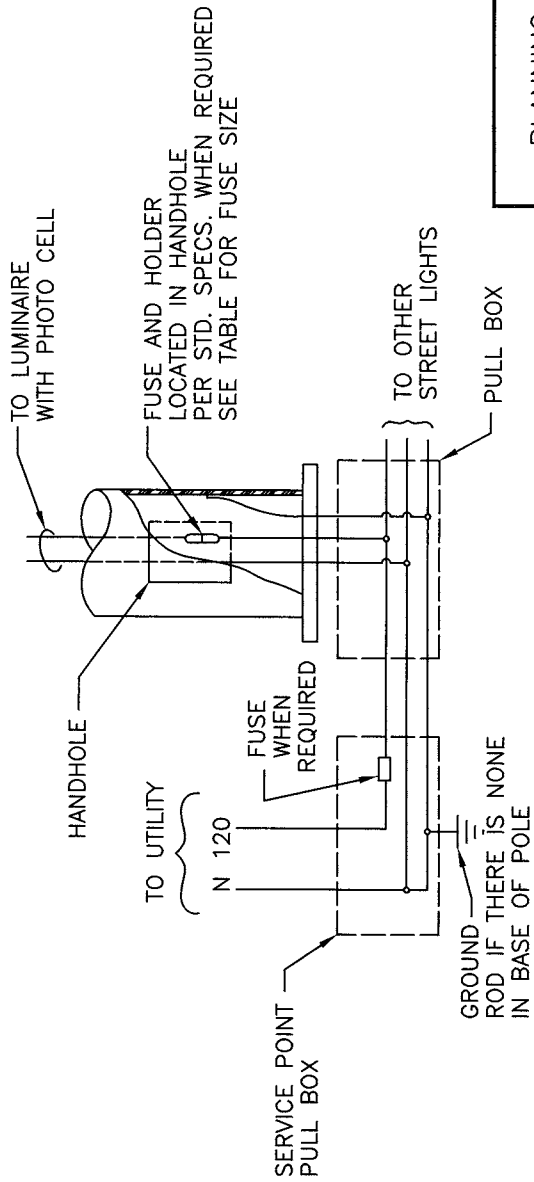

### WIRING DIAGRAM

### NOTES:

1. FUSE SHALL BE A MIDGET FERRULE TYPE, RATED AT 600 VOLTS.
2. ATTACH GROUND CONDUCTOR TO EACH ELECTROLIER.
3. ALL PULL BOXES SHALL HAVE PROVISIONS FOR LOCKING.
4. PULL BOXES SHALL NOT BE LOCATED IN DRAINAGE SWALES. PROVIDE POSITIVE DRAINAGE AWAY FROM ALL PULL BOXES.
5. INSTALL RODENT SCREEN BETWEEN PULL BOX AND PEA GRAVEL, JUST BENEATH BRICKS.
6. PULL BOXES AT JUNCTION BOXES SHALL BE LOCATED AT LEAST 20' FROM FIRE HYDRANTS.

COUNTY OF YOLO PLANNING AND PUBLIC WORKS DEPARTMENT	DATE: 08/05/08
SERVICE POINT PULL BOX	SHEET # 1 OF 1
<i>Panos</i> COUNTY ENGINEER No. C42401	DRAWING #: 5-7 NOT TO SCALE
<i>Boblas</i> APPROVAL DATE 28 AUG. 08	

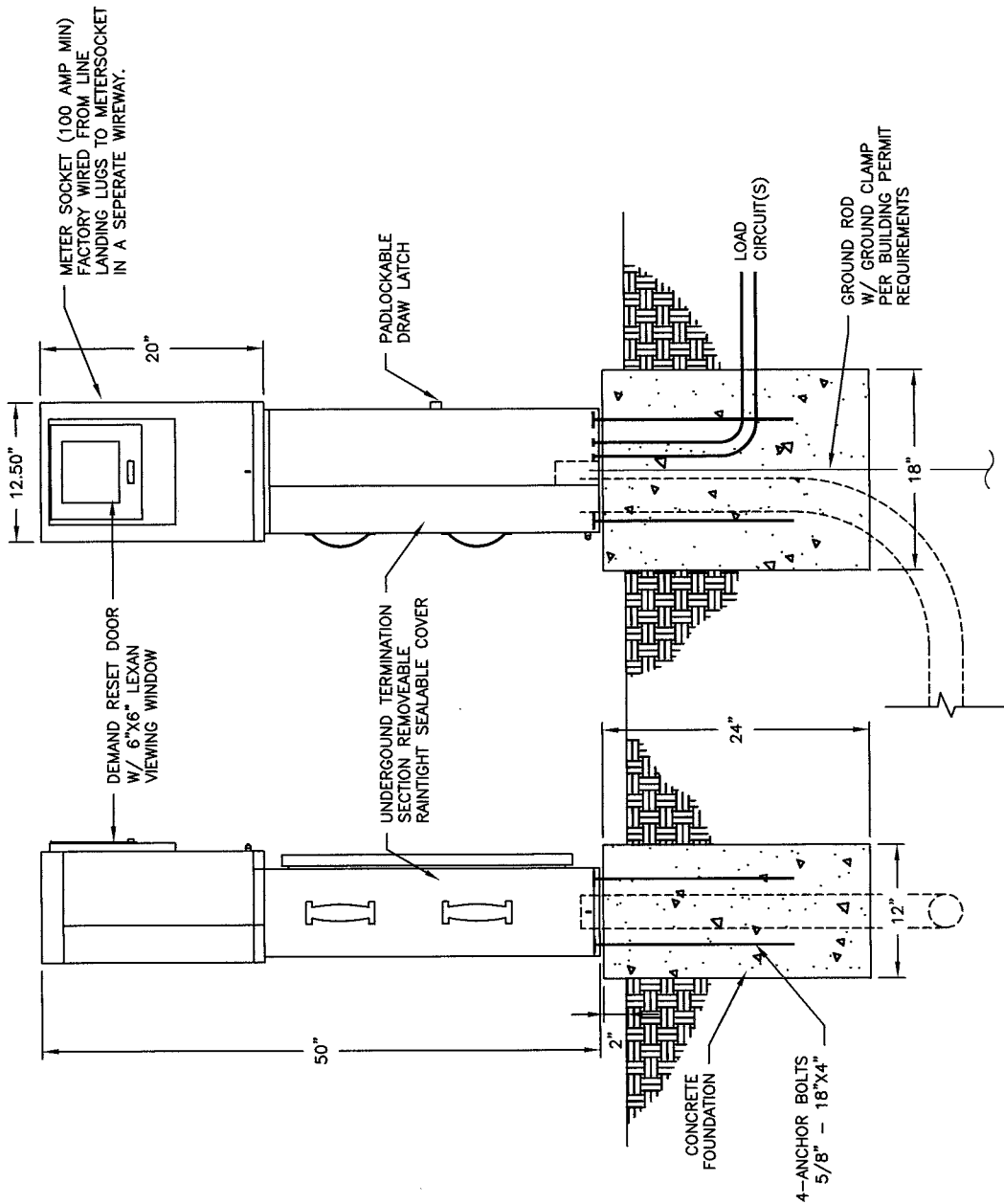

- NOTES:
- SERVICE PEDESTAL AND IRRIGATION CONTROLLER PANELS SHALL BE CONSISTENT WITH THIS DETAIL.
  - LOCATE PEDESTALS SO AS TO MINIMIZE THE POSSIBILITY OF DAMAGE FROM ERRANT VEHICLES OR LANDSCAPE CONTRACTORS.
  - SERVICE PANEL SHALL MEET UTILITY AND EUSERC REQUIREMENTS.
  - DEVELOPER SHALL OBTAIN COUNTY BUILDING PERMIT AS REQUIRED TO INSTALL SERVICE PEDESTAL.
  - PROVIDE 15A GFCI RECEPTICLE INSIDE PEDESTAL.
  - CABINET SHALL BE FABRICATED FROM 304D STAINLESS STEEL.
  - TESCO MODEL 26-000 OR EQUIVALENT.

COUNTY OF YOLO PLANNING AND PUBLIC WORKS DEPARTMENT		DATE: 08/05/08
ELECTRIC SERVICE PANEL		SHEET # 1 OF 1
<i>Panos Koblas</i> COUNTY ENGINEER No. C42401		DRAWING #: 5-8 NOT TO SCALE
APPROVAL DATE <i>28 Aug. 08</i>		

TRENCH WIDTH AS REQUIRED BY EXISTING CONDITIONS AND SPECIFICATIONS

CLEAN FILL TO 95% COMPACTION EXISTING SOILS

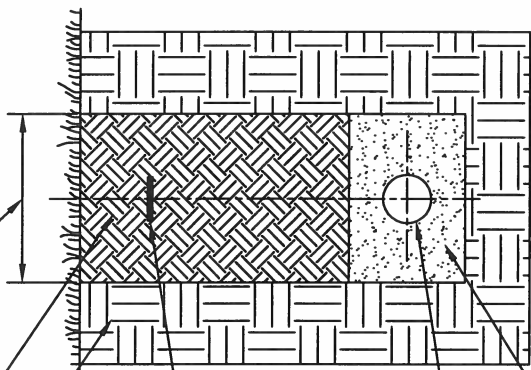

WARNING TAPE (SEE REQUIREMENTS IN SPECIFICATIONS)

36" MINIMUM

TELECOMMUNICATIONS CONDUIT AS REQUIRED BY CONSTRUCTION DOCUMENTS AND SPECIFICATIONS

COMPACTED SAND 2" MINIMUM ALL AROUND CONDUITS

**(A) EXISTING SOILS**

LIP OF GUTTER ON THE NORTH SIDE

TRENCH WIDTH AS REQUIRED BY EXISTING CONDITIONS AND SPECIFICATIONS

2" MINIMUM THICK A.C. OR MATCH EXISTING

\* TWO SACK CONCRETE SLURRY BACKFILL

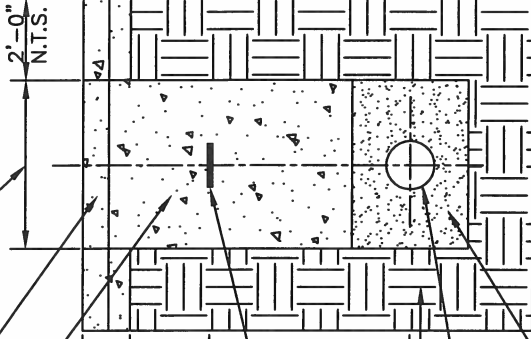

WARNING TAPE (SEE REQUIREMENTS IN SPECIFICATIONS)

\* 36" MINIMUM

EXISTING SOILS TELECOMMUNICATIONS CONDUIT AS REQUIRED BY CONSTRUCTION DOCUMENTS AND SPECIFICATIONS

COMPACTED SAND 2" MINIMUM ALL AROUND CONDUITS

**(B) EXISTING PAVEMENT**

\* NOTE: WHEN IN A PUBLIC RIGHT OF WAY THIS ITEM SHALL CONFORM TO THE REQUIREMENTS OF THE PUBLIC WORKS DEPARTMENT HAVING JURISDICTION

**STANDARD CABLE TRENCH SECTIONS**

**COUNTY OF YOLO**  
 GENERAL SERVICES INFORMATION TECHNOLOGY  
 TELECOMMUNICATIONS DIVISION  
 120 W. MAIN ST. SUITE D  
 WOODLAND CA. 95695

DATE: 03/26/14

SHEET # 1 OF 1

DRAWING #: IT-1  
 NOT TO SCALE

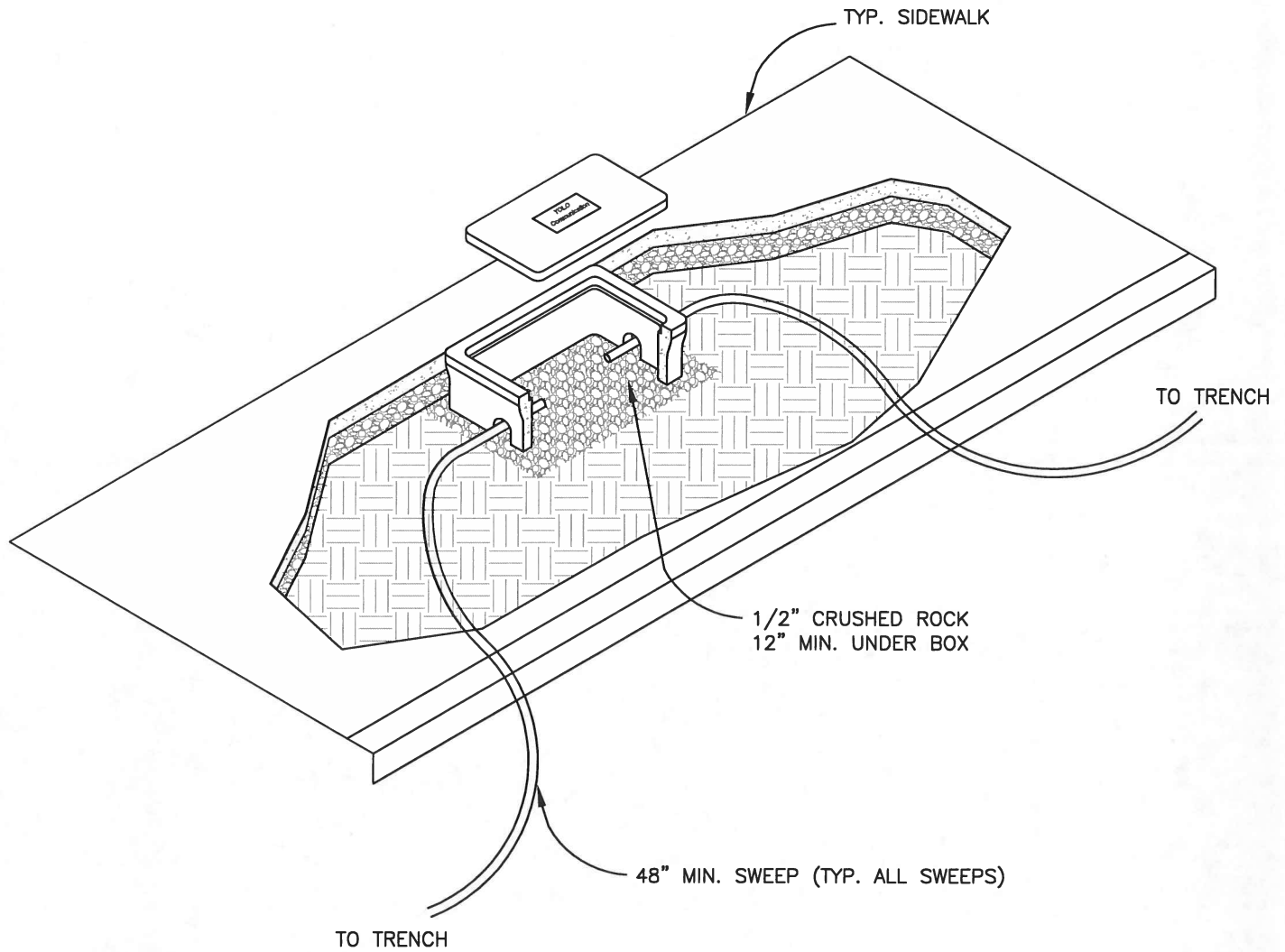

**NOTES:**

1. INTERCONNECT PULL BOXES TO BE SPACED PER SPECIFICATIONS.
2. INLINE PULL BOXES IN NON-TRAFFIC AREAS TO BE CHRISTY PTS1730 OR APPROVED EQUAL.  
 INLINE PULL BOXES IN TRAFFIC AREAS TO BE CHRISTY B1730 OR APPROVED EQUAL.
3. PULL BOXES AT JUNCTIONS IN NON-TRAFFIC AREAS TO BE CHRISTY PTS3048 OR APPROVED EQUAL.  
 PULL BOXES AT JUNCTIONS IN TRAFFIC AREAS TO BE CHRISTY B30" X 48" OR APPROVED EQUAL.
4. PULL BOXES MUST MEET CALTRANS SPECIFICATIONS FOR TRAFFIC AND NON-TRAFFIC AREAS.
5. TOP OF PULL BOX TO BE SET AT EXISTING GRADE.
6. PULL BOX SHALL HAVE BOLT DOWN LID STAMPED YOLO COMMUNICATIONS.
7. CONDUIT SHALL BE 2" DIA.
8. CONDUIT SWEEPS SHALL BE A MIN. OF 48"

<b>FIBER OPTICS &amp; SIGNAL          INTERCONNECT PULL BOXES</b>  <b>COUNTY OF YOLO</b> GENERAL SERVICES INFORMATION TECHNOLOGY TELECOMMUNICATIONS DIVISION 120 W. MAIN ST. SUITE D WOODLAND CA. 95695	DATE: 03/26/14
	SHEET # 1 OF 1
	DRAWING #: <b>IT-2</b> NOT TO SCALE

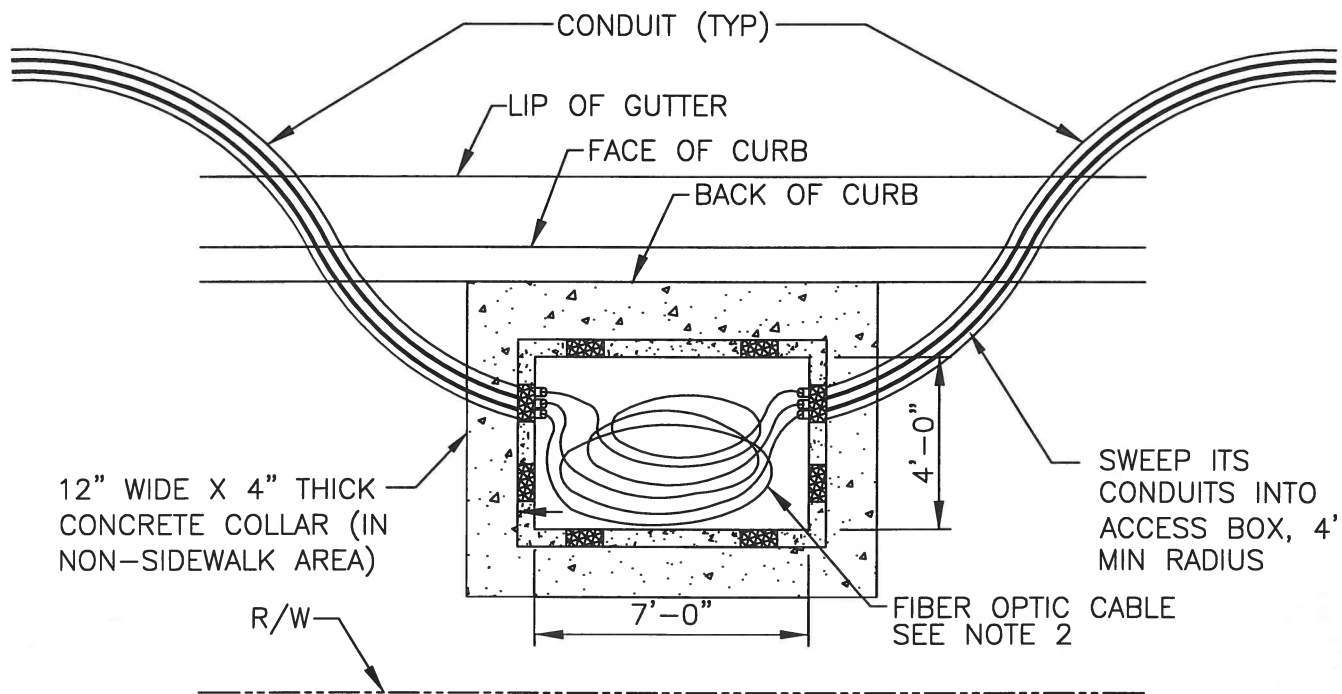

PLAN VIEW

NOTES:

1. TOP THREE CONDUITS NOT SHOWN FOR CLARITY.
2. COIL APPROXIMATELY 50 FEET MIN. OF FIBER OPTIC CABLE AROUND INSIDE BASE OF COMMUNICATIONS VAULT VERTICALLY WITH A MINIMUM DIAMETER OF 32". (ATTACH TO HOLD DOWNS WITH TIE WRAPS) PER SPECIFICATIONS.
3. 90° CONDUIT ENTRIES ARE NOT ALLOWED. CONDUIT SHALL BE DIRECTLY ACROSS FROM ADJACENT CONDUITS.
4. LABEL ALL CABLE IN PULL BOX & SERVICE BOX.
5. VAULT SHALL HAVE A TORSION SUSPENDED & SPRING LOADED LID WITH TWO HOLDUP BRACING BARS.
6. VAULTS SHALL INCLUDE BOLT DOWN LIDS.
7. LABELING ON LID SHALL READ "YOLO COMMUNICATIONS".
8. VAULTS SHALL BE AS REQUIRED BY CONSTRUCTION DOCUMENTS AND SPECIFICATIONS.
9. FOR ADDITIONAL 4' X 7' VAULT DETAILS, SEE STD PLAN IT-4.

<b>4' X 7' VAULT DETAIL 1</b>	DATE: 03/26/14
<b>COUNTY OF YOLO</b> GENERAL SERVICES INFORMATION TECHNOLOGY TELECOMMUNICATIONS DIVISION 120 W. MAIN ST. SUITE D WOODLAND CA. 95695	SHEET # 1 OF 1
	DRAWING #: <b>IT-3</b> NOT TO SCALE

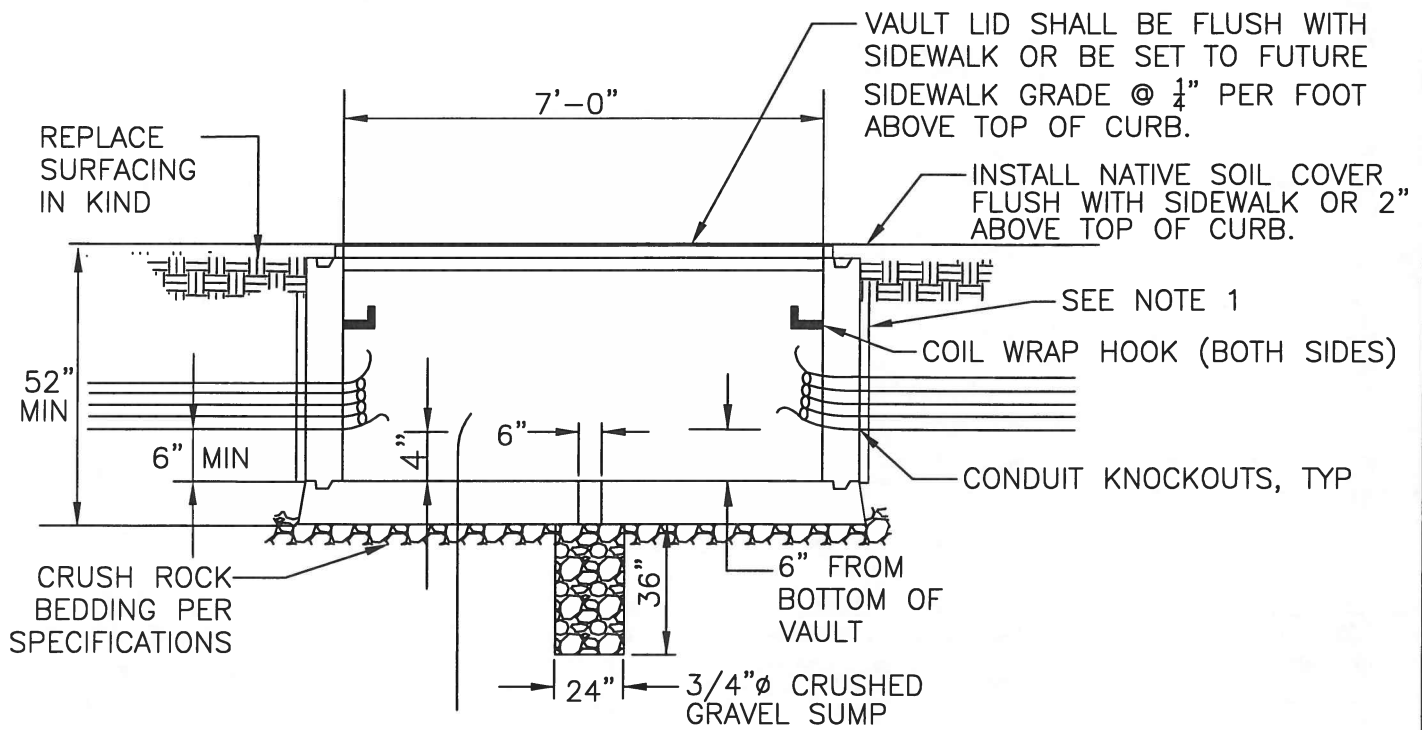

ELEVATION VIEW

NOTES:

1. WRAP VAULT WITH BUILDING PAPER PER SPECIFICATIONS BEFORE BACKFILLING.

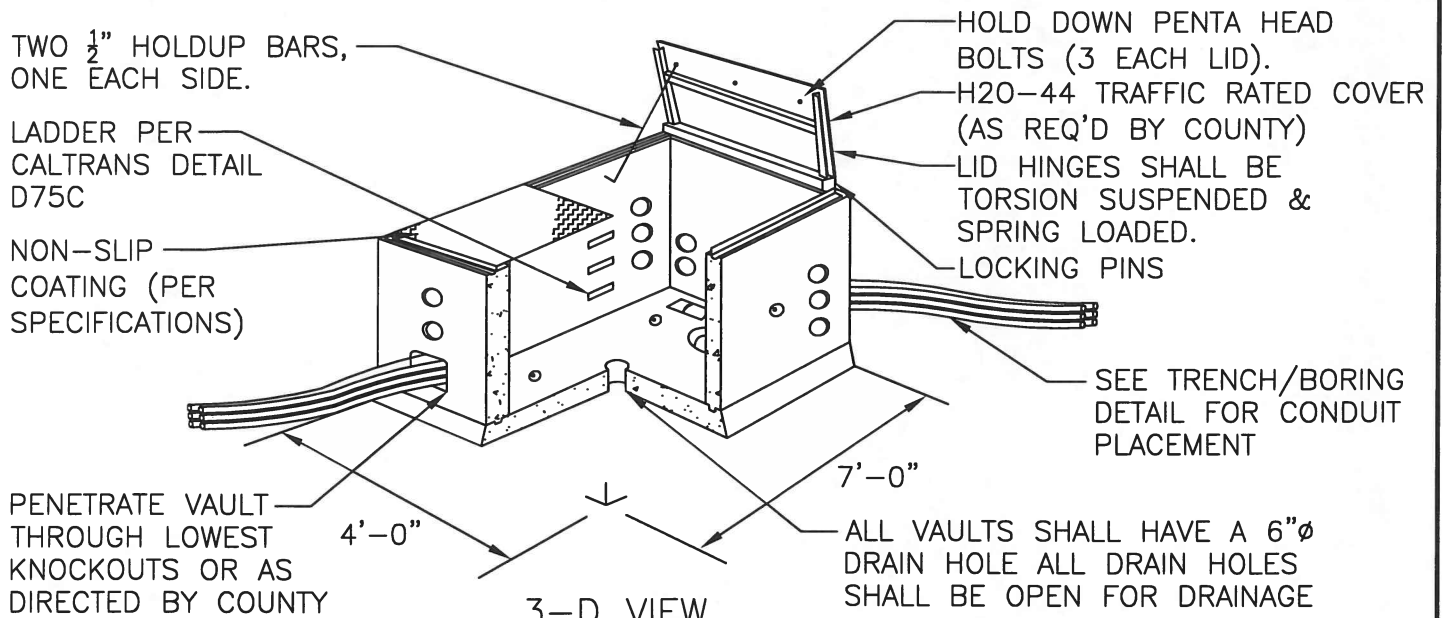

3-D VIEW

<b>4' X 7' VAULT DETAIL 2</b>	DATE: 03/26/14
<b>COUNTY OF YOLO</b> GENERAL SERVICES INFORMATION TECHNOLOGY TELECOMMUNICATIONS DIVISION 120 W. MAIN ST. SUITE D WOODLAND CA. 95695	SHEET # 1 OF 1
	DRAWING #: <b>IT-4</b> NOT TO SCALE

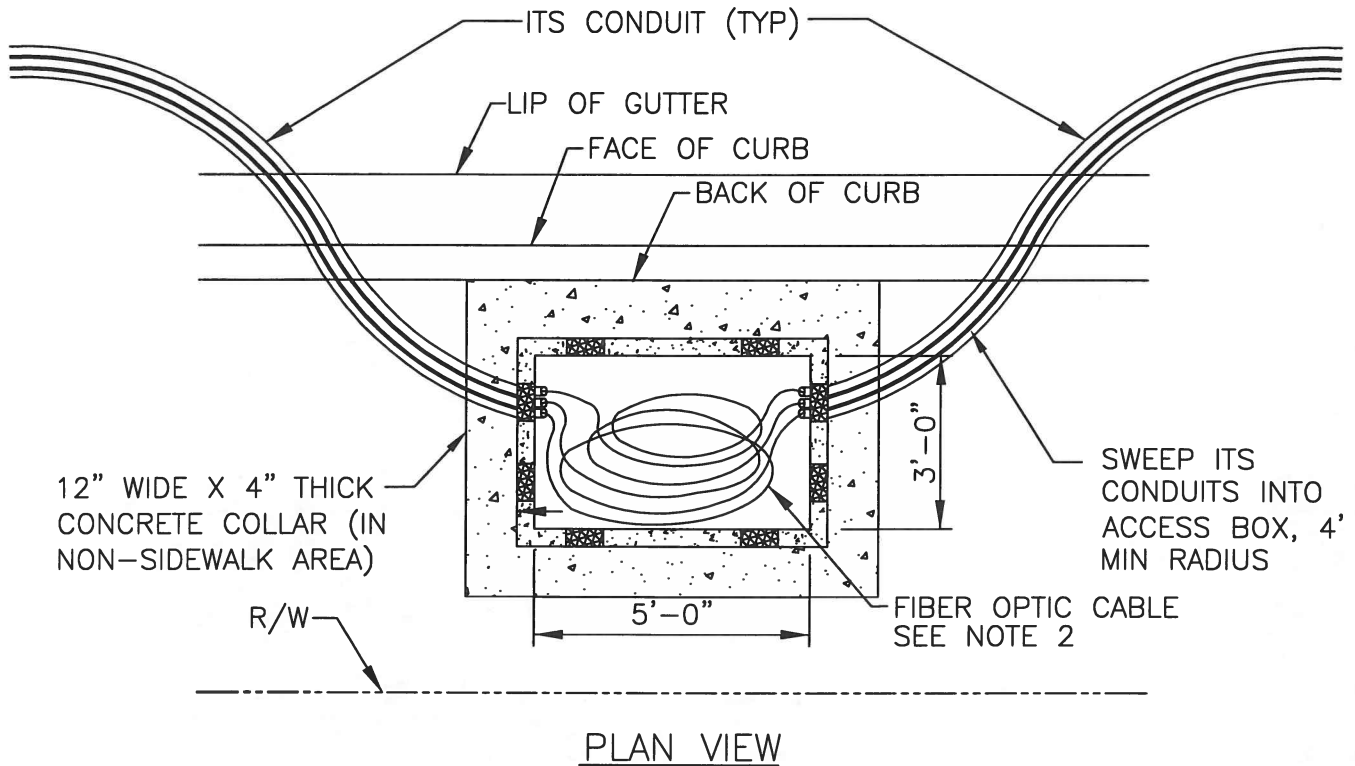

NOTES:

1. TOP THREE CONDUITS NOT SHOWN FOR CLARITY.
2. COIL APPROXIMATELY 50 FEET MIN. OF FIBER OPTIC CABLE AROUND INSIDE BASE OF COMMUNICATIONS VAULT VERTICALLY WITH A MINIMUM DIAMETER OF 32". (ATTACH TO HOLD DOWNS WITH TIE WRAPS) PER SPECIFICATIONS.
3. 90° CONDUIT ENTRIES ARE NOT ALLOWED. CONDUIT SHALL BE DIRECTLY ACROSS FROM ADJACENT CONDUITS.
4. LABEL ALL CABLE IN PULL BOX & SERVICE BOX.
5. VAULT SHALL HAVE A TORSION SUSPENDED & SPRING LOADED LID WITH TWO HOLDUP BRACING BARS.
6. VAULTS SHALL INCLUDE BOLT DOWN LIDS.
7. LABELING ON LID SHALL READ "YOLO COMMUNICATIONS".
8. VAULTS SHALL BE AS REQUIRED BY CONSTRUCTION DOCUMENTS AND SPECIFICATIONS.
9. FOR ADDITIONAL 3' X 5' VAULT DETAILS, SEE STD PLAN IT-6.

<b>3' X 5' VAULT DETAIL 1</b>	DATE: 03/26/14
<b>COUNTY OF YOLO</b> GENERAL SERVICES INFORMATION TECHNOLOGY TELECOMMUNICATIONS DIVISION 120 W. MAIN ST. SUITE D WOODLAND CA. 95695	SHEET # 1 OF 1
	DRAWING #: <b>IT-5</b> NOT TO SCALE

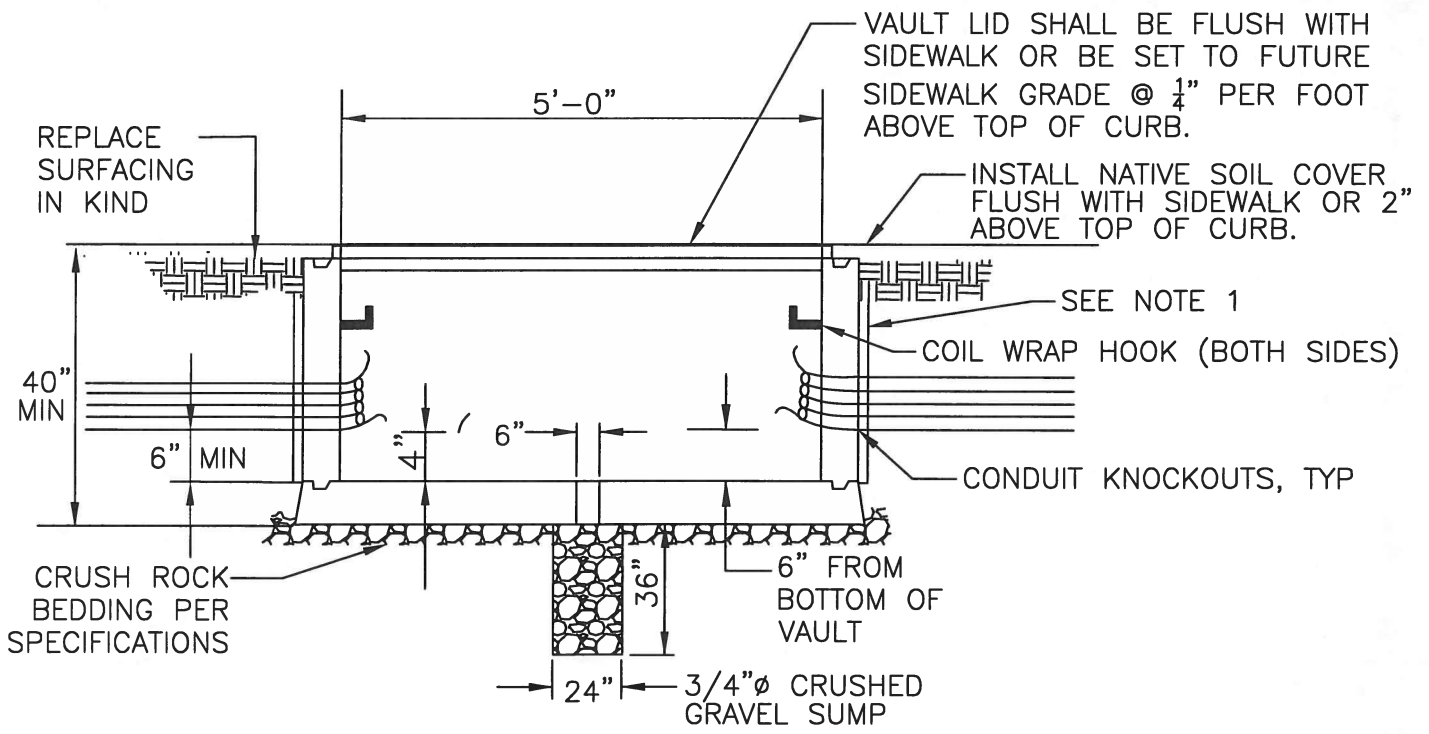

ELEVATION VIEW

NOTES:

1. WRAP VAULT WITH BUILDING PAPER PER SPECIFICATIONS BEFORE BACKFILLING.

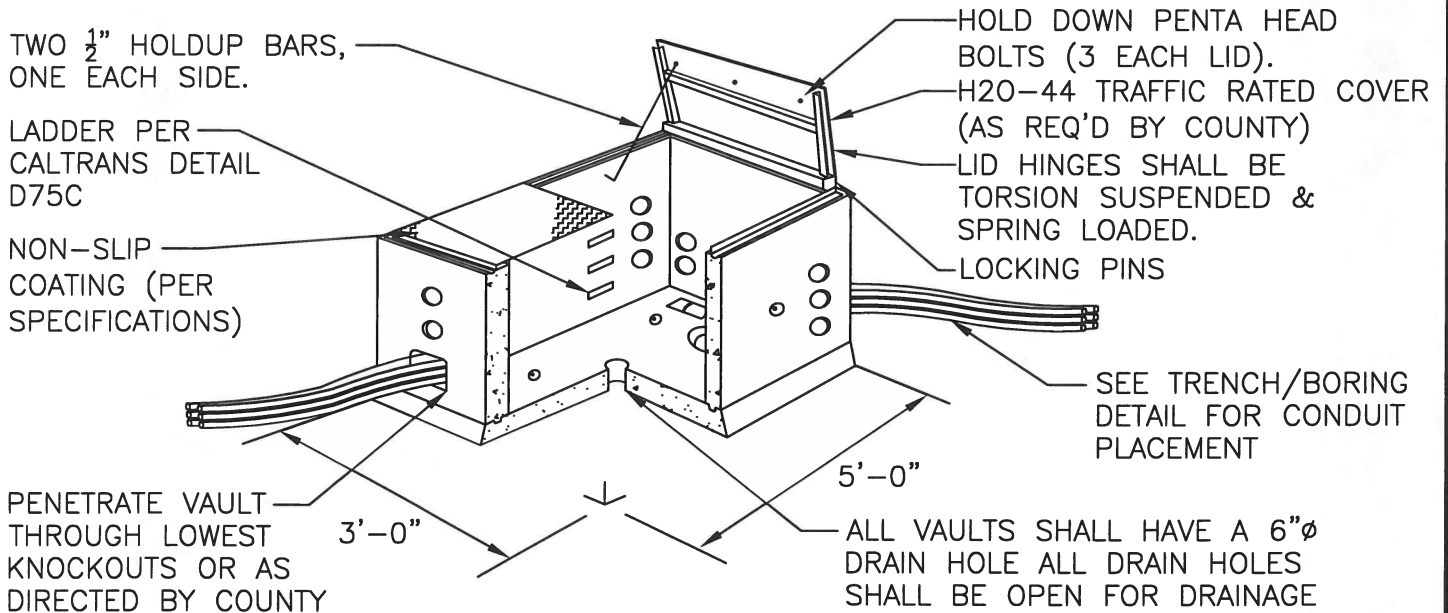

3-D VIEW

<b>3' X 5' VAULT DETAIL 2</b>	DATE: 03/26/14
<b>COUNTY OF YOLO</b> GENERAL SERVICES INFORMATION TECHNOLOGY TELECOMMUNICATIONS DIVISION 120 W. MAIN ST. SUITE D WOODLAND CA. 95695	SHEET # 1 OF 1
	DRAWING #: <b>IT-6</b> NOT TO SCALE



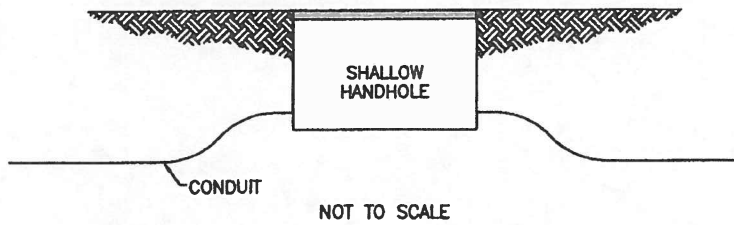

NOT TO SCALE



TYPICAL CONDUIT HANDHOLE ENTRY

**NOTES:**

1. CONDUIT THAT SWEEPS INTO THE HANDHOLE MUST ENTER THE HANDHOLE FLUSH AND LEVEL TO AVOID FIBER MICRO BENDING. WHEN ENTERING A SHALLOW BOX, THE CHANGE IN THE ELEVATION OF THE CONDUIT RUN SHOULD BE KEPT AS SHORT AS POSSIBLE IN ORDER TO MAINTAIN MAXIMUM DEPTH.
2. CONDUIT BENDS CANNOT EXCEED 45 DEGREES IN OR OUT OF HANDHOLE.

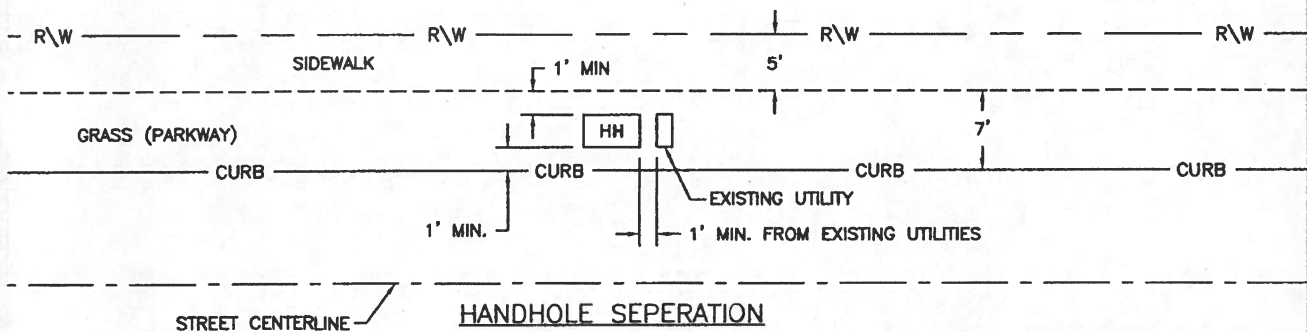

HANDHOLE SEPERATION

NOTE: HANDHOLES SHOULD NOT BE PLACED IN SIDEWALK UNLESS APPROVED BY CITY ENGINEER

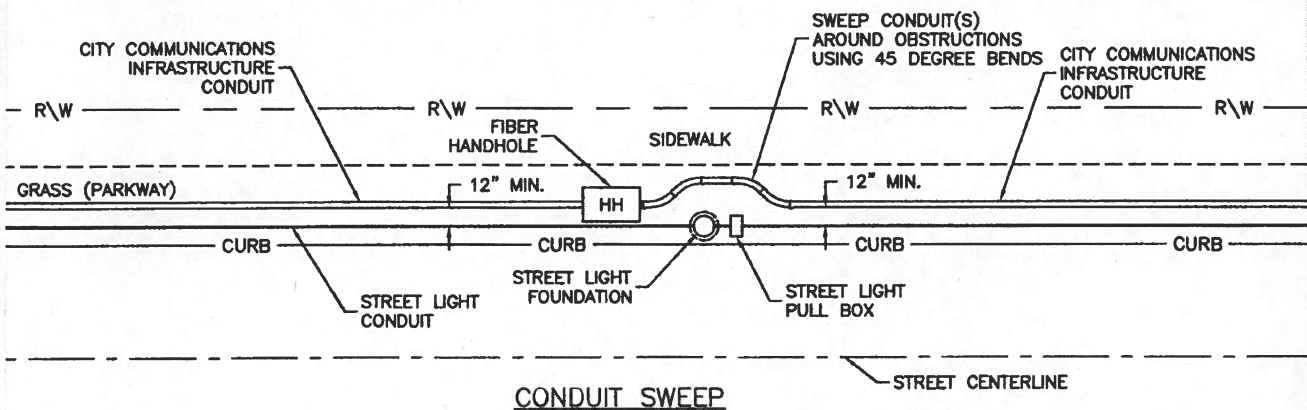

CONDUIT SWEEP

**FIBER OPTIC CONDUIT HANDHOLE ENTRY**

**COUNTY OF YOLO**  
 GENERAL SERVICES INFORMATION TECHNOLOGY  
 TELECOMMUNICATIONS DIVISION  
 120 W. MAIN ST. SUITE D  
 WOODLAND CA. 95695

DATE:  
03/26/14

SHEET #  
1 of 1

DRAWING #:  
**IT-7**  
NOT TO SCALE

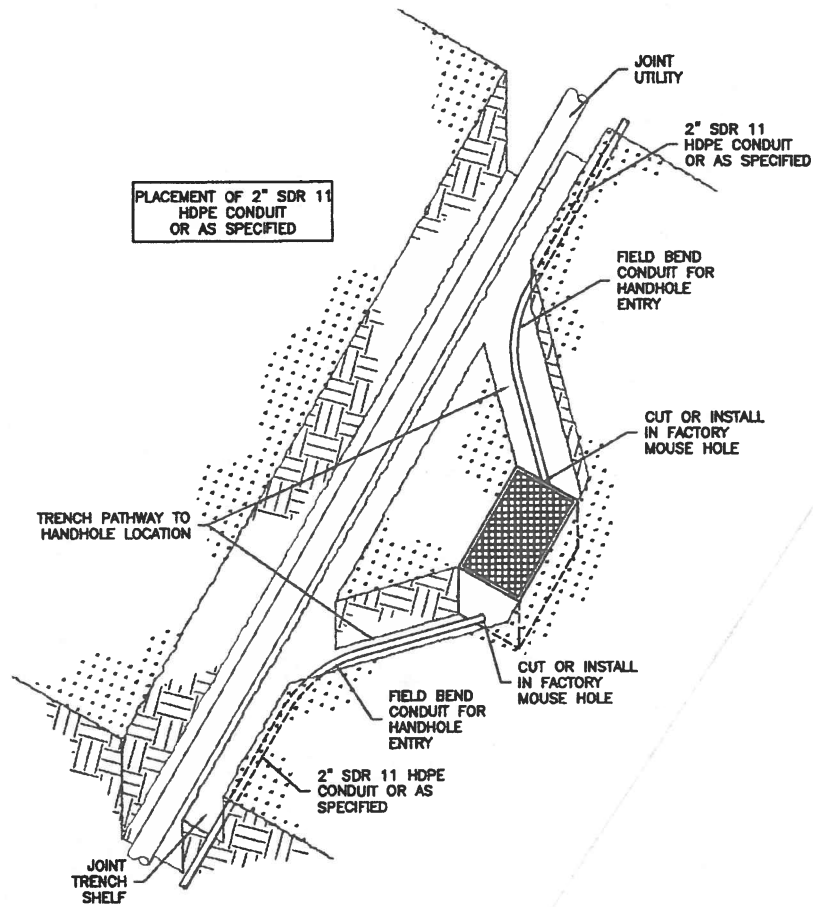

PLACEMENT OF 2" SDR 11 HDPE CONDUIT OR AS SPECIFIED

- NOTE:
1. HANDHOLE SPACING NOT TO EXCEED 500' MAXIMUM LINEAR DISTANCE
  2. MINIMUM ALLOWABLE BEND RADIUS FOR 2" SDR 11 HDPE IS 25 TIMES THE OUTSIDE DIAMETER OF CONDUIT

<b>TYPICAL FIBER OPTIC CONDUIT SWEEP DETAIL</b> <b>COUNTY OF YOLO</b> GENERAL SERVICES INFORMATION TECHNOLOGY TELECOMMUNICATIONS DIVISION 120 W. MAIN ST. SUITE D WOODLAND CA. 95695	DATE: 03/26/14
	SHEET # 1 OF 1
	DRAWING #: <b>IT-8</b> NOT TO SCALE

## **SECTION 6 SOUND BARRIER & SECURITY WALLS**

### **6-1 LOCATION REQUIREMENTS**

Sound barriers or security walls may be required along the rear and side property lines of residential developments adjacent to freeways, major highways, arterials, collectors, and other ground level noise generators in order to achieve the noise objectives of the County of Yolo General Plan, Zoning Ordinance, or as required by the project conditions of approval.

Rear and side yard security fencing adjacent to publically owned lands, rights of ways, or road easements shall not be wood fences. Acceptable materials for sound barriers are masonry or concrete. Where sound barriers are not a necessary component, security walls may be constructed of chainlink or tubular steel fencing.

### **6-2 DESIGN**

The sound barrier shall be designed to meet noise reduction objectives established for the project. Structural calculations prepared by the Design Engineer in accordance with Building Code requirements shall be submitted for review and permitting by the County Chief Building Official. Wall design details and submittals shall also be reviewed and approved by the County Engineer.

Design Details shall include, but are not limited to:

- Materials; either masonry or concrete, including reinforcement
- Wall height and thickness
- Footings
- Earth retention allowances
- Construction requirements
- Special inspection requirements
- Architectural features and any painting, considering colors that can be matched for ease of graffiti abatement

Standard sound barrier designs may be approved for use in the County of Yolo. Any such request shall include plan details and calculations prepared and signed by an appropriate Design Engineer. The Developer shall make an application and pay all related review and approval costs.

Sound barriers shall be installed outside of public rights of way, and shall have a minimum design life of 30 years.

Sound barriers constructed along freeways, or at the back of sidewalk along the outside of curved major streets, shall incorporate a barrier-type design element to minimize the potential for vehicles penetrating the wall. Other locations that represent a higher potential for run-off-road accidents shall be required to incorporate a Caltrans Type 60 (or equivalent) barrier-type design element.

All open or non-reinforced cells in masonry block sound barriers shall be fully grouted. Special inspection shall be required. Decorative split face block, decorative caps, and decorative pilasters may be required.

### **6-3 PLAN REQUIREMENTS**

All construction details for sound barriers and security walls, including the locations and limits, shall be shown on the site improvement plans.

Sound Wall construction details shall comply with APWA “Greenbook” Standard Plan 601-1 unless a project specific design is submitted along with design calculations for review and approval.

**SECTION 7**  
**SANITARY SEWERS**

<b>CONTENTS</b>	<b>Page</b>
7-1 Design Criteria.....	7-1
7-2 Flow Determination.....	7-1
7-3 Design Flow.....	7-1
7-4 Pipe Capacity, Slope, Velocity, Size, Depth And Material .....	7-2
A Size.....	7-2
B. Slope and Velocity.....	7-2
C. Capacity .....	7-2
D. Depth.....	7-2
E. Material.....	7-3
F. Testing .....	7-3
7-5 Groundwater Requirements .....	7-3
A. Geotechnical Reports .....	7-3
7-6 Sewer Locations And Alignment Requirements.....	7-3
A. General.....	7-3
B. Location in New Subdivision.....	7-4
C. Location in Existing Streets .....	7-4
D. Easements .....	7-4
E. Water Well Clearance.....	7-4
F. Alignment .....	7-4
G. Upstream Uses .....	7-4
7-7 Trench Loading Conditions And Pipe Design .....	7-5
A. Conduit Loading .....	7-5
B. Safety Factor .....	7-5
C. Bedding and Initial Backfill.....	7-5
D. Special Pipe Strength Requirements.....	7-5
7-8 Manhole Criteria .....	7-5
A. General.....	7-5
B. Spacing.....	7-6
C. Elevation Criteria.....	7-6
D. Construction Requirements.....	7-6
E. Vacuum Testing.....	7-6
7-9 Drop Connection.....	7-6
7-10 Flushing Branch.....	7-6
7-11 Sewer Services.....	7-6
A. General.....	7-6
B. Sizing .....	7-7

<b>CONTENTS</b>		<b>Page</b>
	C. Connection Limitations.....	7-7
	D. Material.....	7-7
	E. Location.....	7-7
	F. Depth.....	7-7
	G. Service Requirements in Developed Areas.....	7-7
7-12	Creek or Canal Crossing Design.....	7-8
	A. General.....	7-8
	B. Design.....	7-8
	C. Construction And Material.....	7-8
7-13	Jack and Bore Requirements.....	7-8
7-14	Pump Station And Force Main Requirements.....	7-9
	A. Plans for Wastewater Pump Stations.....	7-9
	B. Specifications.....	7-9
	C. Other Requirements.....	7-9
	D. Design Factors to be Considered.....	7-10
	E. Site Improvements.....	7-10
	F. Structures and Appurtenances.....	7-11
	G. Pumps, Motors, and Controls.....	7-14
	H. Piping and Valves.....	7-20
	I. Emergency Provisions.....	7-22
	J. Miscellaneous.....	7-23
	K. Force Mains.....	7-23
7-15	Sewer Improvement Plan Requirements.....	7-24
	A. General Requirements.....	7-24
	B. Plan and Profile Sheets.....	7-24
	C. Detail Drawings.....	7-25
	D. Connection to Existing Facilities.....	7-25
7-16	Design Of On-Site Sewer Systems-Private Multiple Ownership Residential Developments ....	7-25
	A. Planned Unit Developments and Townhouses.....	7-26
7-17	Multi-Structural Commercial And Industrial Developments.....	7-26
7-18	Sewer System Master Plan (SSMP) For A Specific Area.....	7-26
	A. General Requirements.....	7-26
	B. Study Map.....	7-27
	C. Report Preparation.....	7-27
7-19	Wastewater Treatment Systems.....	7-27

**SECTION 7  
SANITARY SEWERS**

**7-1 DESIGN CRITERIA**

These Improvement Standards shall only apply to sanitary sewer collection facilities to be maintained by a County Service Area or sewer maintenance district under control of the Board of Supervisors that provides extended sewer services. These Standards are minimum design criteria. The County Engineer may permit modifications or may require higher standards where unusual conditions are encountered. These Standards shall also apply to any privately owned and maintained sanitary sewer collection systems serving 4 or more residential units or any commercial or industrial uses. Where sanitary sewer facilities are to be maintained by a Community Service District or City, the standards of the District or City shall govern the design and construction of sanitary sewer facilities.

**7-2 FLOW DETERMINATION**

Flow determination shall be based upon the approved zoning, existing land uses or General Plan land use designations, whichever produces the greatest flow. The minimum population density used shall be based on the latest US Census Tract data for single-family residential housing. Design flows shall be calculated using Table 7-1.

<b>TABLE 7-1 SANITARY SEWER DESIGN FLOWS</b>			
<b>Land Use</b>	<b>Unit</b>	<b>Minimum Average Daily Flow ( Gallons per Unit )</b>	<b>Peaking Factors<sup>1</sup></b>
Single Family Residential (3.5 persons per unit)	Residence	350	3
Multi-Family Residential (3.0 persons per unit)	Residence	300	3
Commercial, Office	Gross Acre <sup>2</sup>	2,500 <sup>2</sup>	2-4 <sup>2</sup>
Central Business District	Gross Acre <sup>2</sup>	3,500	2-4 <sup>2</sup>
Light Industrial	Gross Acre <sup>2</sup>	2,000 <sup>2</sup>	2-4 <sup>2</sup>
Heavy Industrial	Gross Acre <sup>2</sup>	3,000 – 5,000 <sup>2</sup>	2-4 <sup>2</sup>
Recreation and Parks	Gross Acre	200	2
Elementary School	Student	50	3
Middle School	Student	50	3
High School	Student	60	3
1: Peaking Factors may be increased or decreased based on flow peaking studies for trunk mains and pumping stations. 2: Subject to review and confirmation of intended uses and waste generation rates. Industrial uses may require private pre-treatment and/or peak reduction facilities.			

The infiltration and inflow allowance shall be 600 gallons per gross acre per day.

**7-3 DESIGN FLOW**

Design flow shall be calculated using the average daily flow for the upstream service area, as described in Section 7-2, unless more current design criteria is available in a Sewer System Master Plan.

The following formula shall be used to calculate the design flow:

$$Q_d = (Q_a \times PF) + I$$

- Where:
- $Q_d$  = Design Flow
  - $Q_a$  = Minimum Average Daily Flow
  - PF = Peaking Factor
  - I = Infiltration/Inflow Allowance

**7-4 PIPE CAPACITY, SLOPE, VELOCITY, SIZE, DEPTH AND MATERIAL**

- A Size:** The minimum size sewer pipe shall be eight inches in diameter unless otherwise approved by the County Engineer. The minimum size sewer service lateral pipe shall be four inches.
- B. Slope and Velocity:** Minimum slopes of sewer pipes shall be such that the velocity of flow in the pipe when full shall not be less than two feet per second. Manning's formula shall be used to determine the relation of slope, design flow, velocity, and diameter. The Manning's "n" value shall be 0.013.
  1. Table 7-2 shows the minimum slopes for various pipe diameters. Pipe slopes that are less than those listed in this table shall not be used without the approval of the County Engineer. Pipes shall not be artificially oversized to justify the use of a smaller slope. The slopes indicated are based on a velocity of two feet per second with the pipe flowing full, or half full.

TABLE 7-2 MINIMUM SLOPES	
Inside Diameter (Inches)	Minimum Slope
8"	0.0035
10"	0.0025
12"	0.0020
15"	0.0015

2. The maximum depth of flow at design conditions in any collector (12-inch inside diameter or less) shall be 0.7 of the pipe diameter. Mains larger than 12-inches in inside diameter may be designed to flow full unless direct sewer service connections are planned; in which case the 0.7 diameter maximum depth shall govern.
- C. Capacity:** Pipe capacity and invert elevations, in all cases, shall be adequate to carry the design flow from the entire tributary area, even though said area may not be within the project boundaries.
  - D. Depth:** In the design of a system, one of the controlling conditions shall be that the collector system shall be at sufficient depth to provide a minimum slope for the sewer services of 1/4 inch per foot (or 2%), at the same time maintaining a minimum cover of 12 inches at any buildable location within the properties to be served, and a minimum of four feet of cover at the back of sidewalk, except that the depth shall be increased to provide minimum 6 inch clearance from underground (dry) utilities installed at the back of the sidewalk.

Minimum depth of new sewer collectors or mains shall be 6 feet from finish grade to top of pipe. The maximum depth of sewer lines shall be 15 feet, unless approved by the County Engineer. A geotechnical study may be required to determine special backfill requirements for sewer pipelines exceeding 10 feet in depth.



**E. Material:**

1. Polyvinyl Chloride (PVC) C900 Class 200 DR 14 conforming to ASTM D1784 for pipes up to 12-inch, and AWWA C905 Class 200 DR14 for larger diameters.
2. Ceramic Epoxy lined Ductile Iron Pipe with a 40-mil-thick high build multi component lining materials consisting of Amine cured Novalac epoxy with at least 20% by volume ceramic quartz pigments. Protecto 401 Ceramic Lining, or equivalent. Encase ductile iron pipe in clear 4-mil HDPE wrapping tubes in accordance with ANSA/AWWA C105 standards. Secure wrap with three wraps of 10-mil HDPE tape, overlapping each wrap one-half tape width.
3. ABS pipe and fittings at service lateral cleanout assemblies shall be Schedule 40 conforming to ASTM F 628 and ASTM D 2661. All products shall bear the seal of a nationally recognized listing or certifying agency.

**F. Testing:** Sewer lines and laterals shall be air tested in accordance with ASTM F1417 “Standard Test Method for Installation Acceptance of Plastic Gravity Sewer Lines Using Low-Pressure Air.” Acceptance testing shall occur following completion of all trench backfill, and placement and compaction of aggregate base in streets.

Sewer lines and laterals shall be balled and flushed, and a TV inspection shall be made, following placement of aggregate base for street, and prior to paving, to allow defective work to be repaired prior to paving. Complete color recordings and logs of TV inspections shall be submitted to the County. Defective work includes but is not limited to:

- Cracks or breaks in the pipe
- Joint separations > ½”
- Low spots (sags) > 1” depth
- Chipped pipe ends > ¼”
- Protruding, folded, or otherwise deformed gaskets or flexible connectors.

Sewer laterals shall be TV inspected prior to final building occupancy to ensure that the laterals are free of debris and damage.

**7-5 GROUNDWATER REQUIREMENTS**

**Geotechnical Reports:** A Geotechnical Investigation Report with groundwater handling or design recommendations shall be required for all plans where public or private sewer facilities are proposed for construction in high groundwater areas.

In areas where groundwater is expected to be encountered above the flow line of sanitary sewer pipe, cement slurry backfill, concrete dams, geotextile wrapping of bedding rock, or other approved methods shall be utilized in the trench to retard the movement of groundwater through trench bedding material and minimize the potential for subsurface erosion.

**7-6 SEWER LOCATIONS AND ALIGNMENT REQUIREMENTS****A. General:** All public sanitary sewers shall be placed within rights of way dedicated for public streets unless the County Engineer specifically approves the use of easements. In some streets, dual collectors may be required.

There shall be a minimum horizontal clearance of ten feet between parallel water and sanitary sewer mains and the water main shall be higher than the sewer. At crossings, the water main shall be at least 12 inches above the sewer main. If a sanitary sewer force main must cross a water main, the requirements of Section 8-15.B shall apply.

- B. Location in New Subdivision:** In new subdivisions, sewers shall be located six feet southerly or easterly of street centerlines.
- C. Location in Existing Streets:** The County Engineer shall determine where sanitary sewers shall be installed in an existing street, considering factors such as curbs, gutters, sidewalks, traffic conditions, traffic lane conditions, pavement conditions, future street improvements plans, and existing utilities.
- D. Easements:** Permanent easements shall be a minimum of 15 feet wide for sewers up to 18 inches in inside diameter and a minimum of 20 feet wide for larger diameter sewers. Widths shall be increased as required to provide for trench wall slopes of 1.5:1 (Horizontal:Vertical) unless flatter slopes are required by existing soil conditions.

Temporary working easements of adequate dimensions shall be provided to allow the construction within the permanent easement to be completed in a safe and reasonable manner.

- E. Water Well Clearance:** No sanitary sewer interceptor, trunk main, collector, or service shall be placed closer than 100 feet to any water well, public or private, unless the well has been abandoned in full accordance with Yolo County Environmental Health Department permit requirements, or the location otherwise approved, in writing, by the appropriate regulatory (State and/or County) agencies. If a clearance of less than 100 feet is approved, all pipe within that distance from the well shall be of material approved by the County Engineer. In no case shall a clearance of less than 50 feet be allowed.
- F. Alignment:** Alignment of all sewer pipe and structures shall be designed to provide a minimum 10 feet of clear separation from parallel existing or proposed water mains as a means of protecting the water main from contamination. Sanitary sewer lines shall pass beneath water mains at all transverse crossings and shall be placed to provide a vertical clearance of at least one foot between the respective pipes. A minimum of one-foot clearance from all other utilities and/or improvements shall be provided, in accordance with Department of Health Services requirements and California Waterworks Standards, unless otherwise approved by the County Engineer.
1. Horizontal alignment shall be parallel to the street centerline and straight between structures wherever possible. Minimum radius for sanitary sewers 8 inches through 12 inches in diameter shall be at least 140% of the pipe manufacturer's recommendation for minimum radius of curvature. A larger radius shall be used wherever practicable or where necessary to avoid joint deflection in excess of 80% of the pipe manufacturers' recommended maximum. Only factory joints will be allowed. Curve information shown on the plans shall include pipe radius (if not concentric with street centerline), sub-tended angle, length, and if needed, maximum pipe lengths.
  2. Vertical alignment shall provide a constant slope between manholes. If a change in grade is necessary, construction of a manhole shall be required unless the County Engineer approves the use of a vertical curve. In such case, elevations shall be shown at ten-foot intervals throughout the length of the vertical curve. Joint deflections in excess of 80% of the pipe manufacturers' recommended maximum will not be allowed. Only factory joints will be allowed.
- G. Upstream Uses:** Each property owner is responsible for the installation of a collector sewer across their property and/or frontage that will serve all upstream uses within an upstream service area.

### **7-7 TRENCH LOADING CONDITIONS AND PIPE DESIGN**

- A. Conduit Loading:** For rigid conduit, Marston's formula shall be used to determine the load placed on the pipe by backfill. The procedure for rigid pipe is described in the ASCE Manual and Report of Engineering Practice 60 and in similar handbooks. In the absence of specific soils data, as determined by a Geotechnical Engineer, a soil weight of 120 p.c.f. and a  $k_u$  factor of 0.110 shall be used.

For flexible conduits, Marston's formula for flexible conduits as shown in the ASCE Manual and Report of Engineering Practice No. 60 and in similar handbooks shall be used to determine the load placed on the pipe by the backfill. The maximum load allowable shall be determined by pipe deflections computed by the Iowa Deflection Formula (or Spangler's Formula.) The soils reaction modulus ( $E'$ ) shall be estimated using a method acceptable to the County Engineer, and shall consider the modulus values of both the native and the bedding materials (ATV method). The bedding soils reaction modulus ( $E'$ ) used in the deflection calculation shall be 1,000 psi for Type II bedding, utilizing imported material to twelve inches above the top of the pipe. Deflection lag factor shall be 1.5. In the absence of specific soils data, as determined by a soils engineer, a soil weight of 120 pcf, a  $k_u$  factor of 0.110, and a bedding constant of 0.110 shall be used. Placement of flexible conduits within soils equivalent to Class V and types MH and CH of Class IV ASTM D2321 material will not be permitted unless approved by the County Engineer.

- B. Safety Factor:** A safety factor of 1.25 shall be used for reinforced concrete pipe, and 1.5 for all other rigid pipe. Only the three edge bearing strength of the pipe shall be used in the computations for rigid pipe.

- C. Bedding and Initial Backfill:** Bedding types and factors shall conform to Standard Drawing 7-4. Bedding and initial backfill type shall be as necessitated by height of cover over the pipe, trench width, pipe strength, and other factors used to determine safe pipe loading.

Special attention shall be given to backfill requirements for deep trenches, pipes located in State rights-of-way and for pipes placed in areas where trench width is excessive, such as in the vicinity of bore pits. See Section 7-13 regarding this condition. Any special backfill requirements shall be noted on the plans.

Unless otherwise noted on the plans, bedding and initial backfill for all pipe sizes shall be Type II, with trench widths subject to limitations set forth in Standard Drawing 7-4. The minimum trench width for all rigid pipe shall be pipe O.D. plus 12 inches.

Type III bedding and initial backfill are intended primarily for emergency field conditions. Their use shall normally not be specified on the plans and shall require specific written approval of the County Engineer before use.

- D. Special Pipe Strength Requirements:** Ductile iron, or other high-strength pipe approved by the County Engineer, shall be used whenever cover is greater than 25 feet, or extra support strength is required (such as to resist traffic loading). Ductile iron pipe or other high-strength pipe approved by the County Engineer, shall be used whenever cover is less than four feet, or insufficient clearance exists between the sewer pipe and rigid or load transmitting structures.

### **7-8 MANHOLE CRITERIA**

- A. General:** Manholes shall be placed at all intersections of sanitary sewer mains, at any change in pipe slope, at any angular or abrupt change in horizontal alignment, at the end of any main terminating in a cul-de-sac, at the end of all permanent mains 120 feet or more in length, and at the end of any temporary main more than 200 feet in length. All manholes from which sewer main extensions are anticipated shall have a pipe stub installed at the grade and in the direction of

the anticipated extension. Summit manholes connecting two sewer collectors are not acceptable. Manholes may be required on lateral lines serving industrial sites in accordance with Yolo County Code section 6-5.307.

- B. Spacing:** Maximum spacing of manholes shall be 400 feet for all straight sewer mains of ten-inch diameter or less. Where sewers are installed with curvilinear alignments, manholes shall be placed at the beginning or end of such curves, and the distance between manholes shall not exceed 300 feet. Where the length of the curve is in excess of 300 feet, manholes shall be placed at intermediate points along the curve. Reverse curves require a manhole at the point of tangency between the curves.
- C. Elevation Criteria:** When two mains of the same size enter a manhole such that the flow of one must change direction more than 20 degrees, or if flow in a single main must change direction more than that amount, the invert grade at the exit must be at least 0.10' below that of the entrance pipe, but in no case shall the crown of the exit pipe be lower than the invert of the entrance pipe. If the pipes entering and exiting any manhole are not of the same size, the crown of the exit pipe shall never be higher than the crowns of pipes entering the manhole. Manholes not meeting these conditions shall be governed by inside drop connection requirements.
- D. Construction Requirements:** Manhole construction shall conform to the provisions of Standard Drawings 7-1 to 7-3. Lock-type or pressure-type manhole covers shall be used on manholes located in easements, and in areas subject to flooding.

If the distance from the crown of the pipe to the top of the rim is less than 6 feet 11 inches, 18-inch high cone shall be used. Manholes shall use flat slab tops that have through mains and less than 5 feet 8 inches from the crown of the pipe to the rim. The plans shall note that the frame on manholes located in unimproved areas shall be set 1.0' above existing ground level, provided with a concrete collar and an object marker.

Manholes located outside of paved areas shall be provided with all-weather access, and shall be located in the center of a 10 foot diameter level all-weather pad, so that they are accessible to maintenance personnel and equipment.

- E. Vacuum Testing:** All manholes shall be vacuum tested in accordance ASTM C 1244. Acceptance testing shall occur following placement of aggregate base and prior to paving.

### **7-9 DROP CONNECTION**

Drop connections are not allowed, but may be approved by the County Engineer. If approved, manholes containing drop connections shall be coated with a protective coating of either a) 40-mil T-lok PVC liner, Ameron Protective Coatings, b) CCS Coating, high build chemical resistance 40-mil epoxy coating by ChemCo Systems, c) Raven 405 epoxy, 60 mils, d) or equivalent. There shall be no more than one inside drop connection into a four-foot diameter manhole.

### **7-10 FLUSHING BRANCH**

A flushing branch may only be used at the end of a collector less than 200 feet in length if the collector extends to a subdivision boundary and if there are definite plans for its extension. If a collector extends to a subdivision boundary, is planned for definite extension, and has no sewer service connections, it may be capped. Flushing branches shall conform to Standard Drawing 7-6.

### **7-11 SEWER SERVICES**

- A. General:** Sewer service laterals shall conform to Standard Drawing 7-5 and shall be aligned at right angles to the main unless otherwise approved by the County Engineer. The sewer service shall extend from the collector sewer to the lot being served. Sewer services shall extend at least one foot beyond the edge of the pavement of any private road. Easements of adequate width to

accommodate the services shall be obtained. A plan and profile of any sewer service shall be supplied to the County Engineer upon request. Construction of the cleanout to grade for all sewer services is required. The cleanout location shall be accurately staked with a 4"x 4" post until final landscaping is completed and service connections are completed.

The location of all sanitary sewer services shall be permanently marked with a 2-inch tall "S" set in the top of concrete curb. Where curbs do not exist, a 2'x2' concrete pad shall be placed around the sewer cleanout box, and a permanent post (2" diameter, galvanized steel, painted white) shall also be installed to mark the location of the sewer cleanout box.

- B. Sizing:** Normal sewer service size is four inches for residential and six inches for multi-family or commercial. Six-inch or larger sewer services shall serve schools and other developments expected to contribute high sewage flows. In addition, sewer services shall be sized according to requirements of the Uniform Plumbing Code, and as determined by the Engineer. If the sewer service and collector are of the same size, a manhole must be constructed.
- C. Connection Limitations:** Sewer services shall not directly connect to sewer mains designed to flow full or to mains more than 16 feet in depth without the approval of the County Engineer.
- D. Material:** The "T" or wye and the sewer service shall be of the same material as the collector to which it connects.
- E. Location:** When sanitary sewers are constructed as part of new subdivision improvements, a separate sewer service shall be constructed between the main and each lot. In new subdivisions or developed areas, unless specifically requested otherwise in writing by the property owner or Design Engineer, sewer services shall be placed on the low side of any subdivision lot or similar parcel with two percent or greater slope across the front. Otherwise, the sewer service shall be placed in the center of said lot or parcel. Consideration shall be given to trees, improvements, proposed driveways etc., so as to minimize interference when the sewer service is extended to service the house. If the property is located such that sewer service is available both to a main located in an easement and also in right of way, sewer service shall be connected to the right of way location unless otherwise approved by the County Engineer. No sewer service shall be located such that future on site construction will result in the main being in such proximity to a water well or water main or water service that applicable health standards will be violated.
- F. Depth:** The Design Engineer shall verify the adequacy of the normal sewer service depth at the edge of easement or right of way to serve the intended parcel. A depth of four feet to crown of pipe, measured from the ground surface at the back of sidewalk shall be considered normal sewer service depth, except as allowed in the event of conflict with dry utilities, as provided for on Standard Drawing 7-5. Whenever greater depth is required, the Design Engineer shall designate the invert elevation of the sewer service at the edge of the right of way or easement on the construction plans. If a joint trench is being utilized for other utilities, the Design Engineer shall indicate on the plans that a Joint trench will exist and shall adjust service elevations as necessary. It shall be the responsibility of the Design Engineer to arrange for coordination of the grade of utilities located in the joint trench and the sewer services.
- G. Service Requirements in Developed Areas:** In developed areas, a sewer service shall be provided to each legal parcel containing a source of sewage and having a property line less than 200 feet from a collector. A property owner's request for sewer service location shall be honored whenever practicable. Parcels having two or more sources of sewage must have an independent sewer service provided to each sewage source. A sewer service shall be provided to each subdivision lot or lot similar as to size and possible development. At an early stage of design, the Design Engineer shall send every property owner affected by the proposed work a questionnaire requesting, in writing, the owner's preferred sewer service location. In absence of a response to this questionnaire, the Design Engineer shall provide a sewer service as required by this Section.

In addition, when sewer services are staked immediately prior to construction, each property owner shall be given notice that he should give consideration to the staked location of his sewer service and, if not satisfactory, immediately notify the Design Engineer. The date of notification, nature of change, and other pertinent information shall be recorded. Compilation of this information shall be the responsibility of the Design Engineer and the information shall be furnished to the County Engineer upon request.

### **7-12 CREEK OR CANAL CROSSING DESIGN**

Advance approval of the County Engineer and of other appropriate agencies is necessary prior to initiating design. Copies of required permits shall be provided to the Department prior to approval of the plans.

- A. General:** In all cases, the proposed future creek or canal bed elevation shall be used for design purposes. Crossing details of pipe, piers, anchorage, transition couplings, etc., shall be shown on a detail sheet of the plans.
- B. Design:** Calculations shall be submitted which clearly indicate the design of the pipe and supports regarding impact, horizontal and vertical forces, overturning, pier and anchorage reactions, etc.
- C. Construction and Material:** For collector sizes ten inches and smaller, ductile iron pipe or other pipe material as approved by the County Engineer shall be used under the full channel width, plus ten feet each side, unless the pipe is four feet or more below the channel bed elevation. For main sizes twelve inches and larger, pipe used shall be as directed by the County Engineer. Special care shall be taken to provide a firm base for the pipe bedding. The plans shall specify that all soft or organic material within the channel banks shall be replaced with select imported backfill. In addition, the pipe shall be encased in concrete or soil cement shall be used to protect the pipe for the full width of the channel. Unless otherwise directed a clay soil plug shall be required at the top of the pipe at the downstream side of the crossing. The plug shall be a minimum of four feet in length, shall extend the full width of the trench, and shall extend twelve inches above and below the pipe or as approved by the County Engineer.

If the pipe must cross above the channel, ductile iron or welded steel pipe shall be used. Steel pipe may be cement lined and coated, fusion epoxy lined and coated, or glass lined; the County Engineer shall specify or approve the type of coating and lining specified, and the gauge, class, or thickness of the pipe.

Reinforced concrete piers of adequate depth shall be located as necessary for adequate support of the pipe. The pipe shall be held in cylindrical cradles, formed in the pier tops, by galvanized steel straps, with galvanized anchor bolts of adequate size. Cushion material shall be placed between the pipe, clamps, and support. The invert elevation at the point of maximum deflection of the suspended pipe shall be invert of the pipe at its downstream support.

### **7-13 JACK AND BORE REQUIREMENTS**

Where use of conductor casing is specified, the casing shall be reinforced concrete pipe. The casing shall be of sufficient diameter to allow dry sand to be blown into the void between the carrier and the conductor and to allow adjustment of the carrier pipe to grade. Normally, an inside diameter six inches greater than the outside diameter of the couplings of the carrier pipe is sufficient. Reinforced concrete pipe conductors must be designed for the loading condition and, if jacked, the additional loading imposed by the jacking operation.

Direct dry boring of reinforced concrete pipe and of the portion of sewers and sewer services, which pass beneath curbs and gutter, sidewalks, and other obstructions, up to a maximum length of 15 feet, is

permissible. Six-inch and smaller pipelines may be installed by wet boring where approved by the County Engineer. Pipe material used in the small size dry and wet bores shall be ductile iron pipe, or Class 200 (DR-14) PVC pipe conforming to the requirements of AWWA C900.

Backfill in bore pits shall be given special attention with respect to preventing structural failure of the pipe entering or exiting the conductor, and adequate bedding and initial backfill shall be specified.

## **7-14 PUMP STATION AND FORCE MAIN REQUIREMENTS**

Every phase of pump station design, including force mains, shall be closely coordinated with and shall be under the direction of the County Engineer. Pump station features shall include, but not be limited to, buried non-corrosive wet well, duplex (redundant) submersible pumps & motors, above ground weather proof enclosure for automated controls, telemetry, SCADA, remote dialing alarms, phone service, power supply, backup power generator powered by natural gas or propane (LPG), lighting, all weather access, sulfide related corrosion control or reduction, life cycle cost analysis of proposed features, etc. Force Main features shall include, but not be limited to, non-corrosive pipe materials, pipe routing, exit manhole sulfide related corrosion control or reduction, life cycle cost analysis of proposed features, etc.

### **A. Plans for Wastewater Pump Stations**

1. General Layout:
  - a. Plot plan showing layout of site and building(s), including driveway and number of parking stalls, exterior piping and appurtenances, fencing, and utilities. Property ties shall also be shown.
  - b. Plans and details of grading, drainage, erosion control, landscaping, and sprinkler system.
  - c. Show FEMA flood elevations if area is in a 100-year flood plain.
2. Detail Plans:
  - a. Architectural plans, elevations, and details.
  - b. Structural plans, elevations, sections, and details.
  - c. Utility plans (electrical, mechanical, etc.) showing exact location and elevation to prevent damage from future excavations.
  - d. Mechanical plans including pump, isometrics, plumbing, ventilation, air condition and other equipment installations, piping layout, and details.
  - e. Electrical and telemetering plans and details including conduit schedule and lighting fixture layouts, control equipment arrangement, and wiring diagrams (one line and elementary control diagrams) for power distribution and controls.
  - f. Wastewater level control arrangement for operating pumps and alarms.
  - g. Other plans, sections, elevations, schematics, details and notes, as required, to adequately show the proposed construction.

**B. Specifications:** All work shall be in accordance with these Improvement Standards. Special provisions shall supplement the Improvement Standards and shall specify in detail the construction of the wastewater pump station, and all appurtenances.

### **C. Other Requirements:**

1. Design Calculations: Calculations pertinent to the design shall be submitted to the Planning and Public Works Department. Such calculations shall be used by the County for determining the adequacy and feasibility of the proposed facilities under review. Any failure on the part of the Developer or authorized representatives to submit such calculations will delay the review and approval of the desired project.
2. Revisions to Approved Plans and Specifications: Any deviations from these specifications shall be approved by the County Engineer in writing before such changes are made. Any deviations shall be submitted well in advance of any construction work which will be affected by such changes to permit sufficient time for review and approval.

3. **Operation During Construction:** Existing facilities and pump station units shall be kept in operation during construction.
4. **Equipment Manuals:** Equipment manuals shall be provided for each pump station. The manuals shall contain sufficient information on the installation, operation, maintenance, and repair of the pump station equipment. Manuals shall be bound in looseleaf “D” binders. Folders shall contain only the information in relation to the equipment furnished. Each binder shall be labeled on its front cover and spine with the name of the facility and subject matter. Two sets of manuals shall be provided to the County.
5. **Facilities Operations and Maintenance Manual:** A detailed operations and maintenance manual for the facilities to be constructed shall be required for all pump station projects. The manual shall give the operations and maintenance personnel the proper understanding, techniques, and any other information necessary to efficiently operate and maintain their facilities. Operations and maintenance manuals shall comply with all applicable State and Federal statutes, ordinances, and regulations. Two sets of manuals shall be provided to the County.
6. **Initial Start-Up Procedure Training:** Services of field engineers or qualified personnel for all equipment provided shall be required to assist and instruct the County's operating and maintenance personnel. Such services shall commence before final acceptance testing.
7. **Spill Prevention Plan and Emergency Response Plan:** The facility's O&M manual shall include sufficient operating instructions in the form of a spill prevention plan to prevent spills. The emergency response plan shall also provide instructions to the operator on how emergencies are to be handled. Two sets of manuals shall be provided to the County.
8. **One Year Certification:** A certification shall be prepared after one year of facility operation documenting the performance of the facility. This certification is intended to confirm that the facility is operating as planned and there are no problems with the equipment. The certification should be prepared by the facility designer, construction manager, or other registered engineer approved by the County.

**D. Design Factors to be Considered:**

1. **Type of Station (Built-In-Place Wastewater Pump Station):** All pump stations shall be built-in-place and may be either dry or wet well type. Premanufactured pump station systems may be considered upon review by the County Engineer.
2. **Wastewater Flows and Design Capacity:**
  - a. *Wastewater Flows.* Wastewater flows shall be determined in accordance with County Improvement Standards.
  - b. *Design Capacity.* Wastewater pump stations shall be designed to discharge design flows.
  - c. *Location:* Wastewater pump stations shall be located where tributary areas will be most effectively serviced and where development, construction, and operational costs would be at a minimum. Pump stations should not be subject to flooding and shall be readily accessible. Wastewater pump station sites shall be adequate to allow on-site parking of service trucks and equipment and to buffer adjoining properties from noise. Future modification and expansion requirements shall be given consideration.

**E. Site Improvements:**

1. **Grading:** Wastewater pump stations shall be located two feet (2') above 100-Year Flood Level and provided with adequate drainage facilities to carry away storm waters. Adjacent properties shall not be jeopardized by such provisions.
2. **Driveways and Parking Areas:** Paved driveways and parking areas shall be provided for service trucks. Width of driveways shall be 12 feet minimum. Pavement shall be asphalt or Portland cement concrete. Concrete curbs shall be required for all pump stations. Entrance gates shall be set inward, toward the station, at least 18-feet to allow trucks entering or leaving the station to pull off the adjacent street.



3. Fencing: Pump station sites shall be fenced in with a six-foot (6') high fence or wall. Masonry walls or other approved types of enclosures are required if pump station is located adjacent to a residential project. Where chain link fences are used, wire fabric shall be nine gauge minimum, galvanized, and plastic coated with color determined by the County. In isolated areas, three strands of barbed wire should be installed along the top of the fence on an arm projecting outward at an angle of 45 degrees. A one foot (1') wide gravel strip shall be provided under fencing. Gravel strip shall be contained with redwood or other approved durable material headers.
4. Gates: Gates shall be provided with heavy duty padlock hasp fixtures and shall be designed for safe opening and closing during strong winds. At facilities where PG&E transformers and/or meters are installed within the station's perimeter, hasps shall be designed to accommodate two padlocks. Design shall allow access with either padlock removed.
5. Landscaping: Sites shall be landscaped to blend with the surrounding environment to render a pleasing overall appearance. Consideration shall be made to minimize groundskeeping maintenance. Chain link fencing shall be screened with landscaping.
6. Sprinkler System: Automatic sprinkler systems shall be installed for lawn/foilage irrigation.

**F. Structures and Appurtenances:**

1. Architectural Design: Wastewater pump stations shall be architecturally designed to be in harmony with surrounding development. Materials shall be selected to keep construction and maintenance cost at a practical level. As much as possible, non-corrosive materials shall be used. All architectural design shall be prepared by a Registered Architect.
2. Substructure: Built-in-place pump station substructures shall be reinforced concrete construction. All substructures shall be waterproof and watertight. Test borings shall be made to determine the soil characteristics and ground water conditions at all pump station sites and foundations shall be suitably designed. Consideration shall be given to flotation during construction and/or flooding condition. Ensure that NPSH requirements of pump are met. Structural backfill for the lift station shall be placed as engineered fill, in lifts not exceeding 12 inches in compacted thickness. Each layer shall be uniformly moisture conditioned to at least the optimum moisture condition and compacted to at least 95% of the maximum dry density per ASTM D1557-91 specifications.
3. Backfill: Backfill around the lift station well shall consist of clean crushed rock with 100% passing through a one inch (1") sieve and no appreciable amount passing through a #4 sieve. A minimum of 12 inches (12") of crushed rock shall be placed at the base of the sewer lift station footing for stabilization and extending a minimum of 12 inches (12") outside the edge of cast-in-place or pre-cast base. In all areas the crushed rock shall be separated from the native material with an approved non-woven geotextile fabric. With approval of the County Engineer, excavated soils may be used for backfill, after required drying has occurred to allow the specified degree of compaction to be achieved. Imported soils must be free of organic concentrations, rubble or debris and must have approval of the County Engineer. The contractor may find it necessary to use deep wells to lower the water table in lieu of using sump construction and pumping. If sheet piling is used the contractor shall extend the tips to a sufficient depth to prevent "quick" conditions or sand "boils" from occurring. The excavation for the sewer lift station may require the contractor to use special construction techniques, which may include but not limited to, sloped excavation, shoring and/or sheet piling, or a combination of methods. The contractor shall submit to the County Engineer for review and approval all shop drawings and proposed methods of construction.
4. Dry Wells: Dry wells shall be sized to meet space requirements for equipment, piping and ease of maintenance. Adequate working space, at least two feet (2') clear, shall be provided between and around pumps and other equipment. Provide three feet (3') clearance for electrical equipment to comply with the National Electrical Code. Space and provisions for planned future pumps and equipment shall also be provided.

5. Wet Wells: Wet wells shall be designed on the basis of minimizing deposits of solids, preventing wastewater from becoming septic, and avoiding frequent starting of pumps. Minimum pump cycle (period from start to start) for any one pump shall be 5 minutes, but not less than the pump manufacturer's minimum pump cycle time rating. Maximum retention time of wastewater in wet wells shall be 30 minutes at average flow (total wet well wastewater volume shall be used in computing retention time). Wet wells shall have a minimum inside width of five feet (5') and shall be sized to keep wastewater levels within the following limits:
  - a. High water level. Desired: at invert of incoming sewer. Maximum: at crown of incoming sewer.
  - b. Low water level. Not lower than top of pump casing.
  - c. Vertical distance between pump start and stop levels. Six inches (6") minimum.
  - d. Floors shall have a slope of 1:1 minimum, sloping towards a hopper bottom. The hopper bottom shall be designed for proper installation and function of pump suction inlets. Influent lines shall be designed without vertical drops into the wet well to minimize release of entrained air/gases. The wet well shall be divided into two or more sections, properly interconnected, to facilitate repairs and cleaning. Wet wells shall have a minimum 40-mil PVC 'T-lock' lining to protect against hydrogen sulfide corrosion.
6. Access. Reinforced concrete or structural steel stairways shall be provided for access to dry wells. Stairways shall have a clear passage of at least 30 inches. Stairs shall be provided with permanent non-slip treading. Access shall be provided to all wet well compartments. Access manholes shall be located to best facilitate maintenance operations.
7. Ventilation. Dry well shall be ventilated by a mechanical air exhaust system providing at least one air change every three (3) minutes. Outlets of exhaust system should not be located less than 12 feet from any opening except when exhausting through the roof. Ventilation exhaust shall be located downwind of any inlet openings. Velocity in air ducts shall not exceed 1500 fpm. When required fan capacity is large, the use of two fans shall be considered. Switches for the operation of the ventilation equipment shall be interlocked with the dry well light switch. Ventilation shafts shall be provided for wet well compartments with only one access opening.
8. Drainage. Dry well floors shall be constructed to drain by gravity into trench drains channeled to a sump. The sump pump shall be submersible. Minimum sump pump capacity shall be 25 gpm with exception of stations equipped with water seal systems, hydraulic operated cone-check valves, or similar type equipment. These stations shall be provided with duplex submersible pumps, each capable of pumping at least 50 gpm. A switch for lead/lag operations shall be provided at the Motor Control Center (MCC). Sump pump discharge shall enter the wet well adjacent to and as high as possible to the ground floor level. Trench drains shall be covered with corrosion resistant gratings. Floor framing and anchoring devices for gratings shall be 316L stainless steel.
9. Superstructure: All pump stations shall have a superstructure.
  - a. *Floor Elevation and Area.* The latest flood zone map shall be consulted. Floor areas shall be adequate for mechanical equipment, electrical equipment and controls, sanitary facilities, storage, and future expansion. Adequate working space, at least two feet (2') clear, shall be provided between and around all equipment. Provide three feet (3') clearance for electrical equipment to comply with the National Electrical Code.
  - b. *Height.* Height of superstructure shall provide adequate working height. Whenever possible, height of superstructures shall be adequate to permit the removal of motor rotor from its stator or the removal of other equipment of larger size with the installed hoisting equipment.
  - c. *Materials of Construction.* The following materials are acceptable for construction of superstructures:

- i. Beams and Columns: reinforced concrete or structural steel.
    - ii. Roof: reinforced concrete.
    - iii. Wall: masonry or reinforced concrete.
  - d. *Insect Screens*. All structure openings for ventilation or light, except doorways, shall be equipped with removable stainless steel insect screens.
  - e. *Doors*. Doors shall be of adequate size to permit removal of pumps, motors, and other equipment. Locks shall be keyable to the Department of Planning and Public Works master key.
  - f. *Roofing*. Unless otherwise submitted and approved, roofing shall be pitched, standing seam metal.
  - g. *Railings and Stairways*. Railings and stairways shall conform to OSHA regulations and County-adopted Building Codes.
  - h. *Outdoor Enclosures*. Gages, meters, and control devices installed outdoors shall be mounted within weather protected enclosures. Gages integral of other devices such as bearing thermometer on motors are excepted. PG&E meter location shall permit easy PG&E viewing.
  - i. *Provision for Equipment Removal*: Provisions shall be made to facilitate removing pumps and other equipment for repair and maintenance.
  - j. *Openings*. Openings shall be provided in ground and intermediate level floors of pump stations. Ground level floor openings shall be covered with removable grates and have removable pipe posts and guard chains around its periphery. Stationary posts with removable pipe railing sections shall be provided around intermediate floor openings. All openings shall be provided with portable peripheral curbing and shall be large enough to provide ample room to install or remove pumps and other equipment.
  - k. *Hoists*. Built-in-place pump stations shall be equipped with trolley type hoists traveling on steel beams or traveling bridge cranes. Traveling bridge cranes shall be provided for installations equipped with 6 mgd pumps and larger. Bridge cranes shall be electrically controlled. Hoists for station with a vertical lift of 25 feet or more (pump room floor to top floor) shall be electrically powered. Plug-in type hoists operating on single phase 120 volts may be allowed for small stations.
  - l. *Eye Bolts*. Eye bolts for block and tackle type hoist shall be provided over pumps, valves, header piping, and other locations to facilitate maintenance operations and equipment removal. The load rating of each eyebolt shall be shown on the plans.
  - m. *Headroom*. Sufficient headroom, including room for lifting device, shall be provided to allow pump rotating element to be removed without disturbing the pump volute.
10. Station Facilities: Depending on proximity of station to other available facilities, and on a case-by-case basis, pump stations may be required by the County Engineer to incorporate any or all of the following:
  - a. *Sanitary Fixtures and Accessories*.
    - i. Service sink shall be acid resistant, white enameled, cast iron body, stainless steel rim.
    - ii. Water closet shall be vitreous china, wall hung, close-coupled closet combination with open front, black closet seat without cover.
    - iii. Paper towel dispenser shall be chromium plated.
    - iv. Toilet paper holder shall be chromium plated.
    - v. Paper toilet seat cover dispenser shall be chromium plated.
    - vi. Soap dish shall be chromium plated.
    - vii. Waste paper basket shall be plastic or noncorrosive material.
    - viii. Wall mirror shall be a minimum 12 in. x 24 in.
    - ix. Small storage cabinet for janitorial supplies shall be a minimum 12 in. wide, 18 in. high, and 8 in. deep.

- b. *Light Fixtures and Receptacles.* Electrical systems shall conform to the National Electric Code.
  - i. *Light Fixtures.* Light fixtures shall be provided to supply adequate illumination within pump stations and shall be mounted where relamping can be accomplished with reasonable ease. Light fixtures shall also be installed next to exterior doors on the outside and around the perimeter of the building with at least one light over the wet well cover manholes. Wet wells shall not require light fixtures. Light fixtures below ground level shall be vapor-tight. Fluorescent fixtures using 48 inch T-8 type tubes are preferred. High pressure sodium fixtures shall be used where appropriate.
  - ii. *Night Lights.* Night lights shall be provided above all building entrances and equipped with lamp shades to prevent glare beyond the perimeter fence line. Consideration shall be made for a night light at the perimeter entrance gate. Night lights shall be automatically controlled by photocells.
  - iii. *Emergency Lights.* Battery-powered emergency lights shall be provided at all floor levels of the pump station and emergency generator location or building. Emergency lights shall be connected to the normal service via a receptacle, mounted adjacent to the emergency light.
  - iv. *Receptacles.* Weather-proof receptacles shall be installed at all floor levels of pump station and outside the building, adjacent to the wetwell.
- c. *Telephone.* Terminal cabinet and touch tone instrument shall be provided.
- d. *Miscellaneous Equipment.*
  - i. *Fire Extinguishers.* Fifteen lbs. CO2 for MCC room and generator area. Ten lbs. dry chemical for lower floors. All fire extinguishers shall be wall mounted.
  - ii. *First aid kit.*
  - iii. *Eight inch electric clock.*
  - iv. *Plastic trash receptacle, thirty gallons capacity with cover.*
  - v. *Desk and chair.*
  - vi. *Storage cabinet for flammable materials.*
  - vii. *Legal size drawer file cabinet with lock.*

**G. Pumps, Motors, and Controls:**

1. *General.* Major pump stations shall be equipped with a minimum of three pumps. Smaller pump stations may be equipped with two pumps. Pumps shall be capable of operating over the range of flows without excessive cycling and without long retention time. Variable speed drives shall be utilized for wastewater pump stations and whenever conditions such as long retention periods or short pumping cycles cannot be avoided. Dual speed motors may be considered where appropriate. All pump stations shall be equipped with a standby pump equal in capacity to the largest of the main pumping units. The main pumping units shall be capable of handling the station's design flow without the use of the standby unit. Pumps shall be capable of passing spheres of at least two inches (2") and shall have a minimum discharge opening of four inches (4") in diameter. Speed of pumps shall not exceed 1200 rpm. Pumps shall be capable of safely rotating in reverse direction at full runaway speed without damage to appurtenances under the shutoff head of the units. The brake horsepower required at full motor speed at any head along the curve shall not exceed the rated horsepower of the motors.
2. *System Head-Capacity Curves.* Pumps shall be selected so that the head-capacity characteristics correspond as nearly as possible to the overall station requirements. This shall be accomplished by the preparation of the system head-capacity curves showing all conditions of head and capacity under which the pumps will be required to operate. The system head-capacity curves shall be developed using standard hydraulic methods for determining friction losses to show the minimum and maximum head losses that can be expected. The equivalent length method using the Hazen-Williams formula is preferred.

Minimum and maximum head losses shall be determined using “C” values. The system head-capacity curves shall consist of the following:

- a. System Curves. Curves showing total dynamic losses in the force main at varying pumping rates for minimum and maximum static heads.
  - b. Individual Pump Characteristic Curves. Curves furnished by pump manufacturer showing pump's head-capacity characteristics. Curves at minimum and maximum anticipated speeds shall be furnished for variable speed pumps.
  - c. Modified Pump Curves. Curves showing pump's head capacity characteristics at the station header, obtained by deducting friction losses in the suction and discharge piping of each individual pump from their characteristic curves at corresponding pumping rates.
  - d. Combined Modified Curves. Curves showing multiple pump operation, obtained by adding capacities at points of equal heads on the modified pump curves.
  - e. NPSH Curves. Curves showing the available system net positive suction head (NPSHA) and the pump's required net positive suction head (NPSHR) shall also be evaluated to minimize the occurrence of cavitation. The NPSHA and NPSHR curves shall include the operating conditions of minimum static suction head and maximum frictional loss ( $C=100$ ) over the entire operating range of each pump. For variable speed pumps where operation of a single pump at the maximum speed will result in cavitation, NPSHA and NPSHR curves shall also be evaluated at the highest variable speed that the pump will experience when it is operated alone or when operated simultaneously with other pumps.
3. Types of Pumps. All pumps shall be vertical units. Motors for stations with pump capacities greater than 2 mgd shall be installed on the ground level floor and connected to pumps with removable driveshafts, intermediate driveshafts, and equipped with removable and adjustable flexible couplings. For pumps of less than 2 mgd capacity, submersible pumps may be used for wet pit installation. Consideration for pump on/off cycling shall be made to avoid high motor temperature. Motors for stations with pump capacities less than 2 mgd may be pedestal mounted.
4. Dry Pit Pump Construction.
- a. Handholes shall be provided on the periphery of pump casings and suction elbows for purposes of inspection and removal of obstructions. Handhole covers shall be flanged and secured to bossed sections and shall have interior surfaces formed to match interior surfaces of casting to which attached. Pump casing handhole shall be located so that visual inspection can be made of the discharge end as well as the volute. Handholes shall be a minimum of four inches (4") or about half of the pump size.
  - b. Pumps shall have flanged suction and discharge nozzles, faced and drilled to conform to ANSI Class 125 lb. standard. Pumps of sizes greater than five inches (5") shall be furnished with suction elbows that are separate and not integrally cast with any other part of the pump. Suction elbows shall be designed to prevent cavitation. Guide vanes shall not be used in suction nozzles.
  - c. Pumps of sizes greater than five inches (5") shall be provided with either fabricated structural steel supports or cast iron ribbed supports. Cast iron supports shall be cast integral with the pump casing or suction nozzle.
  - d. Base or sole plates shall be provided. Plates shall be anchored by stainless steel bolts with stainless steel lock washers and grouted to reinforced concrete pedestals. Hardened steel jacking screws for leveling and for aligning of pumps shall be provided. Mating surfaces shall be machined and all holes drilled and not be burned.
  - e. Intermediate drive shaft sections should be not more than 12 feet in length. Where more than one drive shaft is required, self-aligning steady bearings shall be provided at each intermediate location. Bearings shall be equipped with mechanism to allow alignment adjustments. Bearing and shaft guards shall be provided. Safe access to bearing and

- guards shall be provided. Grease fittings shall be equipped with extension tubing to facilitate lubrication.
- f. Drain and air release lines shall be provided for all pumps. Drain lines shall be installed at the packing drip reservoir and at the centerline of the suction pipe. Air release line shall be installed at high point of pump casings. Connecting points shall be bossed, drilled, and tapped. Air release lines from pump to the first valve shall be brass. Provisions shall be made for a sampling tap for wastewater unless waived by City.
  - g. Other features of pumps shall be as follows:
    - i. Bearing Housing: Of single cast piece or fabricated structural steel.
    - ii. Bearings: Not less than two.
    - iii. Shaft Sleeve: Replaceable stainless steel sleeve, from the outside end of the seal gland to the impeller, and set screwed to the drive shaft.
    - iv. Sealing Gland: Double mechanical seal with suitable fluid sealing/lubrication system.
    - v. Casing and Impeller Wearing Rings: Stainless steel and "Z" or "L" shaped.
    - vi. Suction Plate: Separate from suction elbow (pumps five inches (5") and smaller may be excepted).
    - vii. Taper Pins and Jacking Screws: On all machined joints and handholes.
    - viii. Eyebolts or Other Provisions For Lifting: On volute and bearing housing.
    - ix. Impeller Locknut: With smooth surface, no sharp corners and edges, and easily replaceable.
    - x. Seals: On both the upper and lower sections of the bearing housing.
    - xi. Tapered Shaft: Tapered for the full length of fit and keyed to the impeller. Exception may be made for four inch pumps.
  - h. Stock bronze fitted pumps with cast iron casings and bronze impellers are permitted for temporary installations. Impeller rings and shaft sleeve shall be bronze.
5. Wet Well Submersible Pump.
- a. Handholes shall be provided on the periphery of pump casings and suction elbows for purposes of inspection and removal of obstructions. Handhole covers shall be flanged and secured to bossed sections and shall have interior surfaces formed to match interior surfaces of casting to which attached. Pump casing handhole shall be located so that visual inspection can be made of the discharge end as well as the volute. Handholes shall be a minimum of four inches (4") or about half of the pump size.
  - b. Pumps shall have flanged suction and discharge nozzles, faced and drilled to conform to ANSI Class 125 lb. standard. Pumps of sizes greater than five inches (5") shall be furnished with suction elbows that are separate and not integrally cast with any other part of the pump. Suction elbows shall be designed to prevent cavitation. Guide vanes shall not be used in suction nozzles.
  - c. Base sole plates shall be provided. Plates shall be anchored by stainless steel bolts with stainless steel lock washers and grouted to reinforced concrete pedestals. Hardened steel jacking screws for leveling and for aligning of pumps shall be provided. Mating surfaces shall be machined and all holes shall be drilled and shall not be burned.
  - d. Drain and air release lines shall be provided for all pumps. Drain lines shall be installed at the centerline of the suction pipe. Air release line shall be installed at high point of pump casings. Connecting points shall be bossed, drilled, and tapped. Minimum size shall be d inch. Air release lines from pump to the first valve shall be brass. Provisions shall be made for a sampling tap for wastewater unless waived by the County.
  - e. Other features of pumps shall be as follows:
    - i. Pump shaft shall be stainless steel.
    - ii. Bearings: Not less than two, sealed, and grease lubricated.
    - iii. Seal: Tandem, double mechanical seal running in an oil reservoir. It shall be composed of two separate lapped-face seals, each consisting of one stationary and

- one rotating tungsten carbide ring; with each pair held in contact by a separate springs. The compression spring shall be protected against exposure to the pump liquid.
- iv. Casing and Impeller Wearing Rings: Stainless steel and "Z" or "L" shaped.
  - v. Suction plate: Separate from suction elbow (pumps five inches (5") and smaller may be excepted).
  - vi. Taper Pins and Jacking Screws: On all machined joints and handholes.
  - vii. Eyebolts or Other Provisions for Lifting: On volute and bearing housing.
  - viii. Impeller Locknut: With smooth surface, no sharp corners and edges, and easily removable and replaceable.
  - ix. Tapered Shaft: Tapered for the full length of fit and keyed to the impeller. Exception may be made for four inch (4") pumps.
  - x. Provide sensors and alarms for:
    - High temperature
    - Vibration
    - Seal leakage
6. Motor Construction.
- a. Dry Pit Motor.
    - i. Motors shall conform to the latest standards of the NEMA and the IEEE. Motors shall have ample capacity to operate the pumps under all head and discharge conditions without overloading. Starting current taken by the motors shall not exceed the values as regulated by PG&E or as permitted by the emergency generator. Motors shall be capable of safely rotating in the reverse direction at runaway speed without damage to appurtenances under shutoff head. Motors shall operate pumps through flexible shafts and couplings. Vertical shaft motors mounted on floors shall be furnished with rugged cast iron or steel foundation rings. Motors shall be induction type, drip proof, and suitable for operation from 230/460 volts, 3 phase, 60 cycle A.C. power systems. Motors shall have a service factor of 1.15. All pump motors shall have running time meters installed at the starter. All pump motors above 20 HP shall have an ammeter installed at the starter. Dry pit sump pump motor shall have running time meters installed at the starter.
    - ii. Motors shall be grease lubricated. Motors 7 HP or larger shall be provided with space heaters. Variable speed motors shall be provided with a RPM measuring device with a 4 to 20 milliamp output and a panel mounted digital RPM indicator.
  - b. Submersible Motor.
    - i. Motors shall conform to the latest standards of the NEMA and the IEEE. Motors shall have ample capacity to operate the pumps under all head and discharge conditions without overloading. Starting current taken by the motors shall not exceed the values as regulated by the PG&E or as permitted by the emergency generator. Motors shall be capable of safely rotating in the reverse direction at runaway speed without damage to appurtenances under shutoff head. Motors shall be suitable for operation from 230/460 volts, 3 phase, 60 cycle A.C. power systems. Motors shall have a service factor of 1.15. All pump motors shall have running time meters installed at the starter. All pump motors above 20 HP shall have an ammeter installed at the starter. The motor power wiring shall be brought up directly to the level of the MCC.
    - ii. Pump motors shall be housed in a watertight casing and shall have moisture resistant insulated windings. Pump motors shall have cooling characteristics suitable to permit continuous operation in a non-submerged condition.

7. Indicating Pressure Gauges. Indicating pressure gauges shall be provided at discharge nozzle and suction plate of pumps. Indication shall be in feet. Isolation valves and stainless steel diaphragm seals shall be provided at gauges.
8. Testing. All wastewater pumps shall be factory tested in accordance with the ASME Power Test Codes or the Standards of the Hydraulic Institute. Five (5) certified copies of the pump curves and data shall be furnished with each pump requiring drive motors 40 HP or smaller. For pumps requiring drive motors greater than 40 HP, a witness shop test shall be required and five (5) certified copies of the pump curves, data and report shall be furnished with each pump. Each pump casing shall be tested under a hydrostatic pressure of not less than 60 psi. All impellers, including spares, shall be statically and dynamically balanced. All electric motors shall be tested by the motor manufacturer. Routine tests are required for motors rated at 40 HP or less and Witnessed Complete Tests shall be required for motors larger than 40 HP. Five (5) copies of the certified or witnessed test data shall be furnished for each motor. All pumps shall be field tested to demonstrate satisfactory operations.
9. Spare Parts. All installations shall be furnished with the following minimum spare parts:
  - a. For each pump:
    - i. One set renewable sleeve for the pump shaft.
    - ii. One set of gaskets for all pump casing joints.
    - iii. One set of wearing rings, complete, for both pump casing and impeller.
    - iv. All parts recommended in the manufacturer's O&M manual.
  - b. In addition to the above, provide for each different size pump:
    - i. One complete pump, including suction plate.
    - ii. One set of each type of bearing used in the pump and shafting.
    - iii. One packing gland complete with rings, nuts, bolts, and one box of coil packing (if applicable)
    - iv. One mechanical seal assembly (if applicable).
  - c. For submersible pump:
    - i. One complete pump unit with stand.
  - d. For motor:
    - i. One set of bearings, complete for each size of motor 30 HP or larger.
    - ii. One set of space heaters for each size of motor.
    - iii. One set of brushes for each wound rotor motor.
    - iv. One brush holder assembly (for each size of wound rotor motor).
  - e. For generator:
    - i. All parts recommended in the manufacturer's O&M manual.
    - ii. One circuit board for the voltage regulator.
  - f. For ventilation fan:
    - i. One set of fan drive belts.
10. Starters and Controls:
  - a. Liquid Level Controls. The operation of wastewater pump motors shall be automatically controlled by liquid level sensing devices, actuated by wastewater level fluctuations in the wet well. Ultra Sonic/Transducer type with a 4-20 MA output should be provided. Automatic control settings shall be manually adjustable. Duplicate control units shall be provided for all pump stations equipped with split wetwell chambers. Controlling devices should also be capable of alternating the lead pump and setting off high and low level alarm. The operating range of controlling devices shall conform with the requirements of minimum pump cycle and maximum detention time.
  - b. Selector Switches. HAND-OFF-AUTO selector switches shall be provided to operate pumps. Selector switches shall be located at the motor control center and watertight switches next to pumps. Both selector switch settings must be the same in order for the pump to operate (Example: HAND-HAND or AUTO-AUTO). Automatic and manual



- control for variable speed pumps shall be capable of being adjusted over the effective speed range.
- c. Starters. Unless otherwise restricted by PG&E, starters shall be of the combination, magnetic, across-the-line type. Starters shall be solid-state.
  - d. Control Centers. Starters shall be mounted and wired as an integral part of free standing, unitized, enclosed control centers. Control centers shall be designed and constructed in accordance with the latest standards of the NEMA and the IEEE. Starters for temporary installations may be surface mounted. Control center cabinets shall be installed to permit full opening of doors without interference from adjoining cabinets, walls or other equipment. Split hinge doors may be used to prevent opening interference. All major components of control centers shall be by one manufacturer. If more than one control center is to be installed it shall be of the same type and manufacturer who has a qualified electrical service engineer permanently assigned and residing in Northern California. All panel units, devices, indicating lights, and instrumentation shall be identified by engraved nameplates or metal collars. All starters shall be of the draw out type whereby all control wiring and power conductors are automatically disconnected upon removal of the starter.
  - e. Indicating Lights and Elapsed Time Meters. Appropriate indicating lights and elapsed time meters should be installed for each starter. The running time meters shall be non-resetting, digital display, including a one-tenth hour feature. Indicating lights should be of the push-to-test type or light emitting diode (LED).
11. Instrumentation and SCADA System: SCADA software and PLC's shall conform to equipment as currently used by the County, or as approved by the County.
- a. Instrumentation. Pump stations shall be provided with instrumentation and SCADA systems which include the following:
    - i. Telemeter.
    - ii. Discharge flow.
    - iii. Discharge pressure.
    - iv. Wet well level.
    - v. Run-time pump hours.
  - b. Report-back of operational status:
    - i. Sewage pumps.
    - ii. Sump pumps.
    - iii. Emergency generator.
    - iv. Other items of importance to operations.
  - c. Alarms:
    - i. Normal power source failure (i.e. low voltage, high and low frequency, or phase reversal).
    - ii. Alternate power source failure.
    - iii. Generator operating.
    - iv. Main buss power failure.
    - v. Low level in wet well.
    - vi. High level in wet well.
    - vii. High level in pump room sump.
    - viii. Other equipment failures which could endanger pump station operations.
    - ix. Backup Generator Engine Supervision (i.e., starter failure, low speed, low oil pressure, high water temperature, etc.)
    - x. Building intrusion.
12. Remote Controls. When conditions dictate that installations be remotely controlled from supervisory stations, the following additional functions shall be provided:
- a. Report-back:
    - i. Operational status of each pump (running or not running).

- ii. Operational status of any other item of importance to remote control operations.
  - b. Supervisory remote controls:
    - i. Start and stop pumps.
    - ii. Other functions of importance to remote control operations.
  - c. Alarms:
    - i. Warning of transfer to supervisory remote control operations.
    - ii. Other alarms of importance to remote control operations.
- 13. Relay to Department of Public Works. All readings, alarms, and indications, shall be relayed to supervisory stations designated by the County Engineer.
- 14. Suppliers. Instrumentation systems should be provided by one integrator with field and shop maintenance facilities and full time service engineers located in Northern California.
- 15. Flow Meters.
  - a. Flow meter receiving instruments at the pump station shall be capable of totalizing, indicating, and recording of flows.
  - b. Recorder shall be electronic type with a month duration, four inch (4") wide circular paper chart and a visible face of approximately four inches (4").
  - c. Indicator shall be four inches (4") long or shall be digital with approximately one inch high numerals.
  - d. Flow meter pressure differential producers shall be of the standard venturi type. Insert type differential producers or Dall tubes shall not be permitted.
  - e. All sensors for temperature, pressure, flow, and all other measurement outputs must have 4-20 mA outputs if possible.
- 16. Level Meters.
  - a. Wet well level meter receiving instruments at the pump station shall be capable of indicating and recording wet well levels.
  - b. Recorder shall be electronic type with a month duration, four inch (4") wide circular paper chart and a visible face of approximately four inches (4").
  - c. Indicator shall be four inches (4") long or shall be digital with approximately one inch high numerals.
  - d. Fuel level (inventory) meter shall be installed in the generator room for fuel tank systems.
- 17. Pressure Meters.
  - a. Force main pressure meter receiving instruments at the pump station shall be capable of indicating and recording pressure.
  - b. Recorder shall be electronic type with a month duration, and a visible face of approximately four inches (4").
  - c. Indicator shall be four inches (4") long or shall be digital with approximately one inch high numerals.
  - d. Single recorder with three (3) inputs may be used.
- 18. Instrumentation Panels. All pertinent receiving instruments, devices, alarms, indicating lights, and remote controls shall be mounted on centralized instrument panels. All items shall be identified with engraved nameplates. Electrical power to the panel and all instruments shall be through an uninterruptible power supply unit.
- 19. Indicating Lights. Appropriate indicating lights shall be provided to show the status of equipment operation, alarms, controls, etc. Indicating lights shall be of the push-to-test type or light emitting diodes (LED).
- 20. Amperage Meter. Provide an amperage meter for each sewage pump motor. Amperage metering to monitor all legs.

## **H. Piping and Valves:**

- 1. Wastewater Pump Piping:
  - a. Discharge and header (manifold) piping for wastewater pumps shall be not less than four inches (4") in diameter. Suction piping shall be not less than six inches (6") in diameter.

- b. Velocities in wastewater pump piping shall be as follows:
    - i. Suction from wet well 5 fps (desirable max.) 6 fps (absolute max.)
    - ii. Discharge to header 7 fps (desirable max.) 8 fps (absolute max.)
    - iii. Header (Manifold) 6 fps (desirable max.) 7 fps (absolute max.) 2 fps (desirable min.) 1.5 fps (absolute min.)
    - iv. Discharge risers 3 fps (absolute min.)
  - c. Pipe and fittings shall be cast iron or ductile iron, cement lined and coated on the inside. Cast iron pipes shall be Class 150 and fittings ANSI Class 250. Ductile iron pipe shall be Class 52-minimum. Buried pipe and fittings shall be protected on the outside with an approved corrosion protection coating and cathodic protection. Zinc chromate primer shall be used on the outside for exposed piping to be painted with enamel. Joints shall be flanged with flanges faced and drilled to conform to ANSI Class 125 lb. standard with full face gaskets. Adequate braces and supports shall be provided for piping to ensure no undue strains are induced.
  - d. Piping shall be arranged so that all pumps discharge into a common header. In permanent pump stations, discharge lines shall not enter headers perpendicularly. Base bends, properly supported on concrete pedestals, shall be provided at the bottom of vertical risers. Headers shall be properly blocked to resist water hammer.
  - e. Suction lines shall have turned-down bellmouth inlets. Bottom of the bellmouth shall not be more than  $D/2$  nor less than  $D/3$  (in which  $D$  is the diameter of the suction bell) above the floor of the wet well. Reducers used on the suction side of pumps shall be of the eccentric type to prevent air pockets.
  - f. Gate valves in suction lines, except for temporary pump stations and pump stations with capacity 1 mgd or smaller, shall be provided with extension stems to floor stand operators on the ground level floor. Gate valves shall be solid wedge, rising stem type with iron body, bronze trimmed, outside screw and yoke, and flanged ends. Flanges shall conform to ANSI Class 125 lb. standard except where high pressures are encountered. Valve operators for valves 16 inches or larger shall be electrically motorized. All motorized actuators shall have manual operation back-up provisions.
  - g. Swing check valves shall be provided on the discharge side of pumps and shall be placed horizontally between the gate valves and the pumps. Where damaging effects of water hammer are anticipated, valves with controlled rate of closure shall be installed. Swing check valves shall be iron bodied, bronze trimmed with outside lever and weight, and flanged ends. Flanges shall conform to ANSI Class 125 lb. standard except where high pressures are encountered.
2. Sump Pump Piping: All sump pump fixed piping in wetwells shall be schedule 80 PVC and in dry wells shall be brass. A gate valve and check valve shall be installed on the discharge line. Flanged joints or unions shall be provided on the discharge line to facilitate dismantling of the piping. Minimum diameter of the discharge line shall be two inches (2"). Velocity in discharge risers shall not be less than 3 fps. The discharge point shall be installed at the highest elevation possible to prevent reverse flow when the wet well is filled to capacity. Typical discharge elevation shall be under and close to the ground floor. The sump pump shall be fitted with a flexible PVC hose, minimum two inches (2") diameter. Camlock fittings shall be provided for the PVC hose connectors to the pump and fixed piping.
  3. Waste, Drain, and Vent Lines: Pipe and fittings shall be extra heavy cast iron soil type, except piping installed above ground or inside pump stations and piping two and one-half inches (2 ½") in diameter or smaller, may be standard weight galvanized steel pipe with standard cast iron screwed, recessed drainage fittings. Clean-outs shall be provided as necessary and shall be solid cast brass, rough finish with square heads. Bronze access frames and covers shall be provided for finish floors and walls. Frames and covers for wall

installation shall be square with polished finish. Those for floor installations shall be round with scoriated finish. Clean-outs shall be readily accessible.

4. Potable Water Piping: Water piping and fittings shall be copper except that water piping one inch (1") in diameter and smaller within structures shall be Type K copper pipe with standard brass fittings.
5. Sprinkler System Piping: Sprinkler system piping shall be solvent welded schedule 40 PVC. Lawn risers shall be PVC or polypropylene and shrubbery risers shall be galvanized steel.
6. Piping Between Flow Tube and Instruments: Piping between flow tube to flow transmitter shall be one inch (1") minimum diameter 316 stainless steel. Horizontal runs shall have a minimum declining slope of one-quarter inch (¼") per foot from the flow tube to the in-station equipment and shall be permanently supported and braced to prevent sediment traps and/or air pockets. Piping shall be connected to the flow tube on a horizontal axis. 316 stainless steel valves, unions and necessary fittings shall be installed close to the flow tube to facilitate maintenance. 316 stainless steel ball valves, gate valves, unions, tees and elbows shall be used on the entire system. Flow transmitters and diaphragm seals shall be installed inside the pump station and mounted for easy maintenance access.
7. Pipe Sleeves: Pipe sleeves shall be provided whenever small piping passes through concrete walls. Wall pipe shall be used for larger piping.

#### **I. Emergency Provisions:**

Emergency facilities shall be provided to protect pump stations and the community from possible damages that may result from power failure, emergency maintenance shutdown, pumping capacity being exceeded, or other unforeseen circumstances.

1. Standby Electric Power Equipment: Stations shall be equipped with a natural gas or propane(LPG) powered generator(s) to provide electric power to pump the design flow. The generator's synchronous speed shall be 1800 RPM. The engine generator set shall be a new, standard, current model and in accordance with ANSI and NEMA standards. Provide vehicular access including a pad for a portable generator.
  - a. Operation of the emergency facilities shall be automatic upon power failure. Power failure monitors shall monitor all three phases. Monitoring of one phase of a three-phase system is not adequate.
  - b. Automatic load transfer switches shall conform to PG&E requirements. When possible, bypass of the automatic transfer switch and manual override of automatic functions shall be provided.
  - c. A plug for connection of a portable load bank shall be provided to fully load the generator periodically. The connection shall be made to the generator side of the transfer switch via a circuit breaker. This connection can also be used to connect a portable generator when the installed generator is not available for service.
  - d. Telemetry and SCADA systems shall be powered through an uninterruptable power supply unit. The uninterruptable power supply shall be sized to furnish emergency power for 8-hours minimum.
2. Fuel Storage System: The system shall comply with Federal, State and County regulations. The fuel tank capacity shall be based on two (2) days at design sewage flow and five (5) days at the daily average flow. Underground fuel tank installation shall be designed to prevent surface water infiltration into the fuel tank system. A leak alert monitor shall be provided with capabilities to display fuel inventory, and with audio and visual leak alarms.
3. Portable Pump Facilities: Pump stations shall be equipped to pump wastewater from the wet well into the force main with a portable pump. This shall be accomplished by providing fixed discharge and suction piping for the portable pump with connections to the force main and the wet well. The portable pump discharge piping shall be connected to the downstream side of the flow meter tube and shall include a gate valve, 90° elbow, flanged reducer, and a blind flange. The suction piping shall be connected to the wet well and shall include piping

with a 90° elbow and a blind flange. All piping for the portable pumps shall be sized with consideration to the capacity of the installed pumps and the operating characteristics of the available standby pumps. Portable pumps shall be located near the wet well to minimize the possible occurrence of cavitation. Provide vehicular access including a pad for a portable engine-driven Pump.

**J. Miscellaneous:**

1. Potable Water Supply: All pump stations shall be provided with a potable water supply system for sanitary fixtures, lawn sprinkling, washdown, and other maintenance purposes, as required. Adequate and conveniently located water outlets shall be provided for flushing and washing purposes. Hose bibs shall be 3/4-inch with vacuum breakers at all floor levels and outside of pump station. Stop cock valves shall be provided immediately before each hose bib located within the building. Two conveniently located 1-1/2 inch diameter standpipes shall be provided adjacent to the wetwell. The standpipes shall have 1-1/2 inch angle globe valves for National Standard fire hose thread and end cap with chain. A 3/4-inch hose bib with vacuum breakers shall be installed on the standpipe directly below the globe valve. The main water supply line shall be two inches (2") in diameter, metered and equipped with a master valve located within the station's perimeter fence. A two inch (2") reduced pressure backflow preventer shall also be provided and located within the station's perimeter fence. Under no circumstances shall potable water supply be directly connected to sewage pumps or piping. Seal water, positive air gap and/or pneumatic water tanks shall be provided as necessary. The potable water supply system shall conform to County, State, and Federal codes and regulations.
2. Painting: Pump stations shall have maintenance-free colored exterior finish, subject to County Engineer approval. County may, at its own discretion, approve a painted exterior finish. Painting shall be in accordance with the best practice and in strict compliance with the paint manufacturer's instructions and recommendations. No lead-base primer or paint shall be used. A minimum of two (2) finish coats over one prime coat shall be required.
3. Corrosion Protection: All materials and equipment exposed to corrosive conditions shall be either corrosion resistant or protected with appropriate protective coatings or linings.
4. Odor Control: All stations shall be provided with a 6-inch wetwell vent pipe to be used for treatment of foul odors. The vent pipe shall be schedule 40, 316 stainless steel, permanently installed through the wetwell slab and covered with a blind flange. A receptacle, at appropriate voltage, shall be installed near the vent pipe.

**K Force Mains:**

1. Locations: Force mains shall be located in streets or along road rights-of-way. In locating force mains, ease of installation and maintenance and elimination of high points shall be considered. Air release valves shall be installed at high points.
2. Sizing:
  - a. Force mains shall be sized not less than six inches (6") in diameter (four inches (4") upon approval of County Engineer).
  - b. Velocities in force mains shall be as follows:
    - i. Minimum: 3.0 fps
    - ii. Maximum: 10.0 fps
    - iii. Force mains shall be designed to carry the maximum rate of pumping without excessive frictional head loss. Total dynamic head should not exceed 100 feet.
3. Materials: The material selected shall be adapted to local conditions with special consideration given to the quality of wastewater, possible septic conditions, soil characteristics, internal pressure, abrasion, external loadings, foundations, necessity of reducing the number of joints and other similar problems. Corrosion resistant lining, coating, wrapping, and cathodic protection shall be used. Insulating flanges or fittings may be

required at entrance or exits from buildings. The following material is acceptable for force mains subject to the conditions indicated:

- a. Ductile Iron Pipe (Cement or other approved lining and Coated). Ductile iron pipe shall be wrapped with HDPE plastic wrap and have cathodic protection.
4. Minimum and maximum Cover and Clearances: Shall conform to the requirements as set forth in other sections of these standards.
5. Alignment and Grade: Pipe shall be laid in a straight alignment and with constant grades. Force mains may be curved by deflecting the joints to eliminate the necessity for fittings. In no case shall the deflection exceed the maximum as set forth by the manufacturer for the type of pipe used.

### **7-15 SEWER IMPROVEMENT PLAN REQUIREMENTS**

Plans for the construction of sanitary sewers whether in conjunction with other improvements or for a sewer project only, shall conform to the following standards, as well as other standards contained in the General Requirements and Improvement Plan Requirements of these Improvement Standards.

- A. General Requirements:** All information, which, in the opinion of the County Engineer, is necessary for the satisfactory design, review, construction, and maintenance of a project shall be provided and, where applicable, shall be shown on the plans.

A parcel or area which benefits from and financially participates in a sewer construction project, but is not included within the project boundaries, shall have a note to this effect placed on the layout map and on the plan and profile sheet if the parcel appears thereon. Parcels, which make use of those facilities, may be subject to additional fees at the time of connection, if the participation has not been so noted.

- B. Plan and Profile Sheets:** Sewers shall be shown on the Project Street Improvements Plan and Profile sheets. The following standards, with respect to drafting and the information to be included on the plan and profile sheets, generally apply to projects in developed areas. In new subdivisions, only the requirements that are applicable shall apply.

1. Sewer mains to be constructed shall be indicated on the profile by parallel lines spaced by one pipe diameter. Manholes shall also be indicated by parallel lines spaced according to scale. Pipe slope shall be printed immediately above, and preferably parallel to, the pipeline, or between the parallel lines. The length, size, and type of pipe material between each manhole shall be printed parallel to the horizontal grid lines between manholes. All pipe-inverts at manholes and other structures shall be indicated on the profile. All manholes, flushing branches, or other appurtenances shall be noted on the plan and profile with stationing. Cone heights other than standard, shall be clearly labeled for those manholes requiring the shorter cones due to lack of available depth. Existing facilities shall be shown in profile using dashed lines or shaded lines.
2. In improved areas, the location of each proposed sewer service shall be indicated on the plans by stationing, or by reference to a permanent, well-defined structure, if available. In new subdivisions, the sewer services shall be located by stationing unless the situation exists, such as at the end of a cul-de-sac, where stationing is not an adequate description of location. In such cases a dimension to a lot line may be used. The invert elevation of the sewer service at its upstream end shall be shown on the plans whenever the service is not at standard depth. Standard depth shall conform to the conditions set forth on Standard Drawing 7-5.

Improvements or lots shown on a plan sheet but served to a main shown on another plan sheet shall have the direction of service shown by a small triangle and letter "S".

3. Permanent and working (temporary construction) easements shall be shown to scale on the plans. Easement dimensions shall be shown and each easement shall be dimensioned to the property line and the sewer main. Each permanent easement shown on the plans shall be identified by a box or table, on the same plan sheet, which gives the property owner's name and the Recorder's book and page number in which the easement is recorded. The Design Engineer shall provide the book and page number.
  4. Proposed sewer mains shall be adequately dimensioned from street centerline. If the sewer is to be located outside of the right of way, sufficient dimensions and bearings from an approved horizontal control shall be shown on the plans to locate the main in the field.
  5. Any other existing or proposed gas, electric, water, storm drain, etc., shall be determined and accurately shown on the plans. The location of any utility line which is parallel to and within five feet of the sewer main or which crosses the sewer main at an angle of 30 degrees or less shall be determined with an accuracy of  $1.0 \pm$  foot and the clearance shown on the plans.
  6. Trees, and other objects within 10 feet of construction centerline, shall have their correct location shown on the plans and the clearance from construction centerline shown. The diameter of tree trunks and interfering heavy tree branches shall be noted. Removal of a tree or object, or other special handling shall be noted on the plans. The Design Engineer shall assume full responsibility for such notes as it is the Design Engineer responsibility to make all necessary arrangements with the owner of the object to be handled. Written documentation of any special arrangements regarding preservation of property made between property owners and the Design Engineer shall be supplied to the County Engineer if no easement document is involved. If an easement is negotiated, all special arrangements are to be included in the easement document. The County Engineer must approve tree removal within public rights-of-way or easements.
  7. Culverts shall be shown on both plan and profile when crossed by the construction or when parallel and within 20 feet of the construction line. The size and type of all such culverts shall be indicated and when the culvert crosses or is perpendicular or nearly so and within 20 feet of the construction line, the invert of the culvert end nearest the construction line shall be shown.
  8. Addresses of buildings shall be shown on the plan view, within the outline of the building. Only the front line and indication of sidelines of buildings need be shown.
- C. Detail Drawings:** Items of a special nature should be shown with detail drawings, either on the plan sheets, or on a separate detail sheet.
- D. Connection to existing facilities where bypassing or stoppage of existing flow will be required:** When improvement plans require connection to an existing facility which will require bypassing or stopping existing flows, a note shall be placed on the plans which provides an estimate of the existing flow to be bypassed (in gpm), or the times between which the flow may be stopped. Where the operation will be accomplished on a major trunk or interceptor, submittal of a work plan for review may be required prior to initiation of the operation.

#### **7-16 DESIGN OF ON-SITE SEWER SYSTEMS FOR PRIVATE MULTIPLE OWNERSHIP RESIDENTIAL DEVELOPMENTS**

The following design requirements shall apply to that portion of the sanitary sewer within a privately owned multiple ownership development that is "on-site" and is not an outfall sewer for an upstream area, thereby being considered a private system and not subject to maintenance by a County Service Area. Discharge from such developments shall require an agreement between an owner's association and the sewage treatment provider regarding the operation and maintenance of the private sanitary sewer.

- A. Planned Unit Developments and Townhouses:** Residential developments where separate lots and structures are sold. These differ from usual subdivisions in that adjacent land is owned in common and a homeowner's association performs maintenance.
1. General - Sanitary sewers shall meet all requirements for public sewers contained in these Improvement Standards, except as specified below.
  2. Manhole spacing - Maximum spacing of manholes on collectors shall be 300 feet for all straight runs of pipe.
  3. Wyes - Wyes shall be used for all sewer services connecting to the "on-site" collectors.
  4. Minimum Depth - All collectors located within vehicular traffic areas shall have a minimum cover of five feet to finish grade. Additionally, if the cover over the pipe at any location may be less than two feet at any time after the pipe is installed, ductile iron pipe or Class 200 (DR-14) PVC pipe conforming to the requirements of AWWA C900 shall be installed.
  5. Plan and Profile Sheets - "On-site" improvement plans may be prepared without the sanitary sewer profile that is required by these Improvement Standards, unless otherwise instructed by the County Engineer. However, the final "on-site" grades and drainage facilities must be shown on the plans on the same sheet as the plan view of the sanitary sewers. Pipe dimensions shall be shown adjacent to the corresponding pipe section.
  6. Location - Wherever possible, collectors shall be located in areas to be paved.
  7. Review and Approval - Plans must be reviewed and approved by the County Engineer.

#### **7-17 MULTI-STRUCTURAL COMMERCIAL AND INDUSTRIAL DEVELOPMENTS**

The "on-site" sanitary sewers for all new commercial and industrial developments containing more than one structure shall be designed in accordance with the requirements contained in Section 7-16A of these standards unless otherwise specified by the County Engineer. Any separate building within a multi-building commercial or industrial development shall have its own separate connection to a sewer system designed to public standards.

Flow recording devices for the continuous measurement of discharge volumes may be required by the County Engineer. Grease, oil, and sand separators shall be provided as determined by the County Engineer.

#### **7-18 SEWER SYSTEM MASTER PLAN (SSMP) FOR A SPECIFIC AREA**

Submission of a Sewer System Master Plan (SSMP) for a specific area is required prior to review of the sewer design for new developments for which public sewer services are proposed, or if there is a possibility that upstream or adjacent areas might require service through the subject property. The plan will fully describe the area to be served by the local collection facilities and the facilities necessary to provide that service.

- A. General Requirements:** In order to develop a SSMP the following information must be accumulated:
1. Regional Setting
  2. Topographic map of the area to be served
  3. Any specific projects that precipitated the study
  4. Relevant assumptions or special conditions
  5. Existing and proposed development



6. Ultimate development within the SSMP area
7. Hydraulic grade line at point of discharge into major facilities

The flows generated within each sub-service area of the sub-area plan will be calculated in accordance with the procedures contained in these Standards unless otherwise specified by the County Engineer.

- B. Study Map:** The method of providing sewer service to the entire service area, including pipe sizes and slopes, shall be shown to the extent necessary to determine the requirements within the subject property.
- C. Report Preparation:** In order to insure that all SSMPs are compatible and understandable; they will all be published in the following format.
1. Section Headings - Each SSMP shall be written with the following sections entitled as follows:
    - a. Executive Summary - A concise description of the recommended sewer system, the impacts upon adjacent or Regional systems, and any special design criteria necessary due to unusual local conditions, sealed by the responsible civil engineer.
    - b. Introduction - A thorough background description of the sewer shed, any specific project(s) that precipitated the study, any special conditions, a vicinity map and a topographic map of the study area
    - c. Criteria and Data - All of the information upon which the plan was based shall be delineated in this section in an easily readable manner.
    - d. Plan description - A map showing the service area, the needed sewer facilities (pipes, slopes, flowlines, depths, and service areas), a spread sheet summary, and verbiage describing the collection system shall be included in this section
    - e. Appendices - All of the backup information shall be included in an appropriate number of appendices
  2. Report Format - The SSMP shall be bound as a single document with appropriate dividers between each section and pockets for all the required maps. The approval block shall be in a highly visible location at the end of the Executive Summary.

## **7-19 WASTEWATER TREATMENT SYSTEMS**

Sanitary sewer collection systems shall be connected to existing wastewater treatment systems operated by a Community Service District, City, or other agency where feasible, as determined by the County Engineer. The connection shall be either by gravity flow, or by the installation of pump lift stations. The Developer shall be responsible for applying to the Yolo County Local Agency Formation Commission (LAFCO) for annexations or “out-of-service area” agreements required to accommodate such connections, and shall be responsible for complying with all standards and requirements of the entity that will provide services.

Where a County Service Area (CSA) is proposed to provide wastewater treatment services, the Developer shall be responsible for all costs to create the CSA, prepare an Engineer’s Report to estimate assessments, and provide engineered plans for the wastewater treatment facilities. Such plans shall be prepared by an engineering firm retained by the Developer that 1.) has demonstrated expertise and experience designing municipal wastewater treatment systems, and 2.) is approved by the County Engineer prior to the commencement of design work.

The Developer shall be responsible for obtaining all State and local permits necessary to operate a new wastewater treatment system. The Developer shall be responsible for funding all ancillary equipment required to start-up and operate the treatment system, as determined by the County Engineer. The Developer shall deposit with the County a cash deposit (“Establishment Costs”) to cover the costs to establish the CSA, and costs that may arise from unforeseen circumstances during operation of the facility for the first two years following County acceptance of the facilities, or full project build out, which ever comes later. Such costs may exceed assessments received, the assessment being based on the estimated costs for normal operations and maintenance services, as estimated in the approved Engineer’s Report. Establishment Costs include, but are not limited to the following costs, and are subject to the approval of the County Engineer:

1. Legal and administrative costs incurred by County to establish the CSA, the CSA fund, the CSA budget, and the CSA advisory committee;
2. Administrative costs related to transferring permits into the County’s name, soliciting proposals for third party operations and maintenance services, negotiating and awarding contracts and purchase orders necessary to assume operations and maintenance responsibilities;
3. Administrative and inspection costs related to warranty work that may occur following acceptance of the CSA Facilities, not covered under operation and maintenance contracts or warranty;
4. Materials, parts, and labor costs to refine operations of the CSA Facilities to operate at maximum efficiency, including, but not limited to, modifications to piping, valves, software, telemetry, and controls;
5. Added administrative, operational, or maintenance costs that may be incurred due to low or variable flows during build out of the project, or plant upsets due to construction activities;
6. Periodic maintenance costs (for example, sludge wasting), incurred by the County within one month of acceptance that result from the Developer’s operation and maintenance of the CSA Facilities; and
7. Other unforeseen costs incurred by the CSA following acceptance of the CSA Facilities due to conditions beyond the Developer’s or County’s control, to the extent that the unforeseen costs cause a CSA expense.

<b>Standard Drawings</b>		
<b>Section 7 – Sanitary Sewer Design</b>		
<b>Drawing</b>	<b>Sheets</b>	<b>Description</b>
7-1	1 of 3	Standard 48” Sewer Manhole
7-1	2 of 3	Manhole Base, Camera Channel Detail
7-1	3 of 3	Manhole Base, Camera Channel Detail
7-2	1 of 2	Standard 60” Sewer Manhole (Type A)
7-2	2 of 2	Standard 60” Sewer Manhole (Type B)
7-3	1	Grey Iron Standard 24” Manhole Frame and Cover
7-4	1	Sewer Pipe Bedding and Initial Backfill
7-5	1 of 3	Sewer Services
7-5	2 of 3	Service Cleanout to Grade
7-5	3 of 3	Service Cleanout to Grade Backfill Requirements
7-6	1 of 2	Flushing Branch
7-6	2 of 2	Flushing Branch Frame and Cover
7-7	1 of 2	Utility Crossing
7-7	2 of 2	Utility Crossing

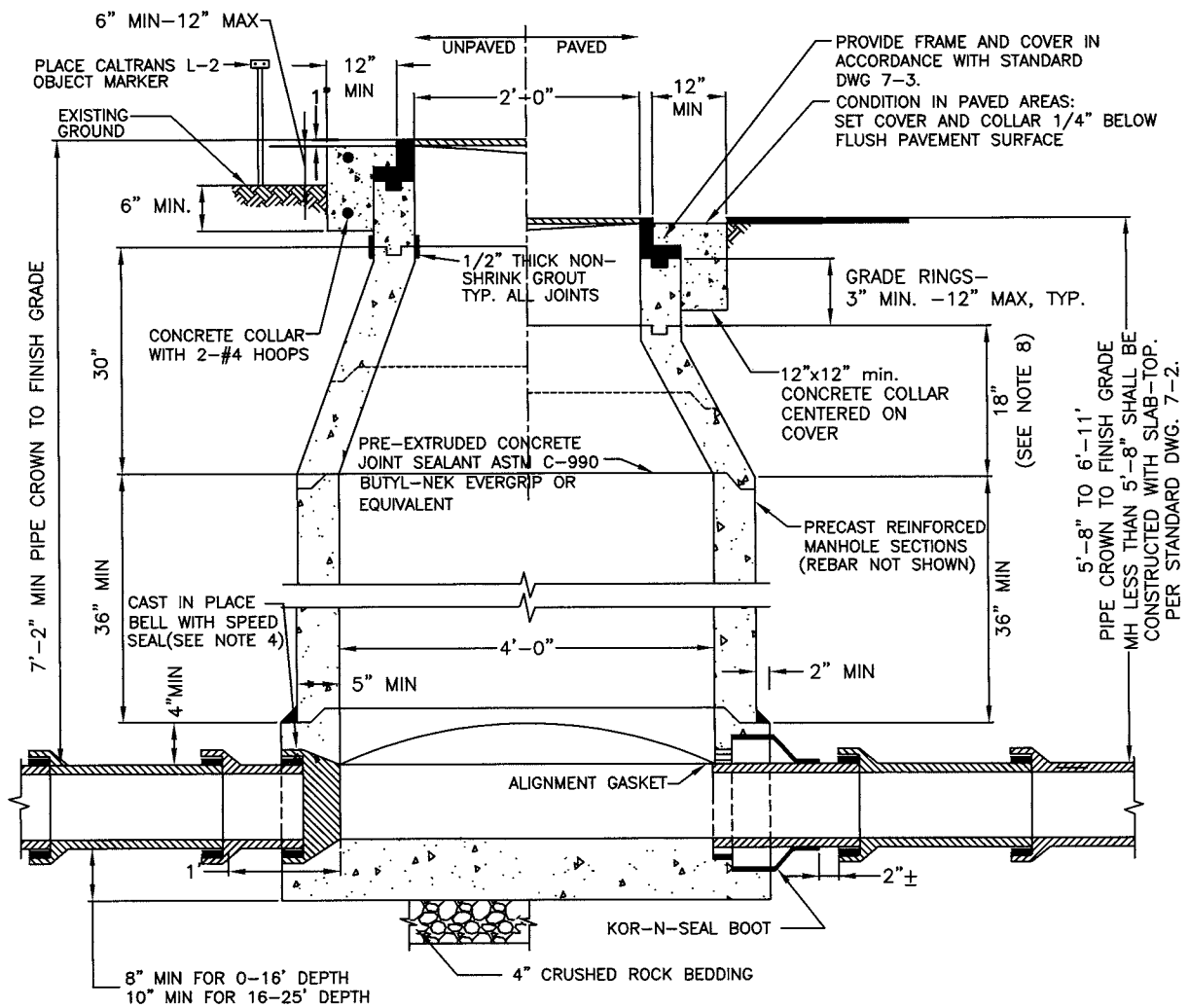

**STANDARD 48" MANHOLE**  
 FOR SANITARY SEWER 12" DIAMETER OR LESS  
 SEE SHEET 2 FOR REBAR

**NOTES:**

1. CLASS A CONCRETE, 6-SACK MIX SHALL BE USED FOR MANHOLE BASES.
2. PIPE SHALL STOP AT INSIDE FACE OF MANHOLE.
3. JOINTS FOR THE BARREL SECTION SHALL BE TONGUE AND GROOVE, ALL LIFTING HOLES SHALL BE SEALED WITH NON METALLIC NON SHRINK GROUT.
4. ALL MANHOLE BASES SHALL BE PRECAST BASES AND SHALL BE PLACED ON 4" MIN OF CRUSHED ROCK PLACED OVER UNDISTURBED MATERIAL. CONNECTION OF THE PIPE TO THE MANHOLE SHALL USE A RESILIENT CONNECTOR CONFORMING TO ASTM STANDARD C923 SUCH AS KOR-N-SEAL, A-LOK, OR APPROVED EQUIVALENT. ALL MANHOLE BASES TO INCLUDE AN ANTI-FLOATATION RING PER DRAWING 7-1 SHEET 2.
5. ANY SERVICE SEWER ENTERING A MANHOLE SHALL BE INSTALLED WITH THE INVERT ELEVATION OF THE SERVICE PIPE MATCHING THE CROWN ELEVATION OF THE EXIT SEWER EXCEPT WHEN AN INTERNAL DROP CONNECTION IS USED. IF THE MANHOLE AT THE END OF A CUL-DE-SAC IS CONSTRUCTED WITH A PRE CAST BASE. THE INVERT OF ANY SERVICE STUBS SHALL BE A MINIMUM OF ONE INCH ABOVE THE INVERT OF THE EXIT PIPE.
6. BEDDING FOR PRE CAST MANHOLE SHALL BE SELECT IMPORTED MATERIAL 1/2" OR 3/4" CRUSHED ROCK (4" MIN).
7. THE STANDARD CONE MAY BE PROVIDED AS TWO PRE CAST SECTIONS.
8. CUL-DE-SAC MANHOLES OR END OF LINE MANHOLES WITH A DEPTH OF 6'-11" OR LESS SHALL USE 18" CONES.

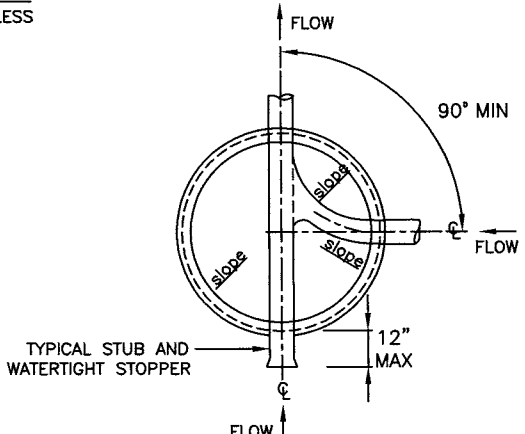

**PLAN VIEW OF 48" MANHOLE**  
 SHOWING INTERSECTING SEWERS

COUNTY OF YOLO PLANNING AND PUBLIC WORKS DEPARTMENT		DATE: 08/05/08
STANDARD 48" SEWER MANHOLE		SHEET # 1 OF 3
<i>Paros Kallas</i> COUNTY ENGINEER No. C42401	28AUG-08 APPROVAL DATE	DRAWING #: 7-1 NOT TO SCALE

**CAMERA CHANNEL  
REQUIRED FOR ALL LINES**

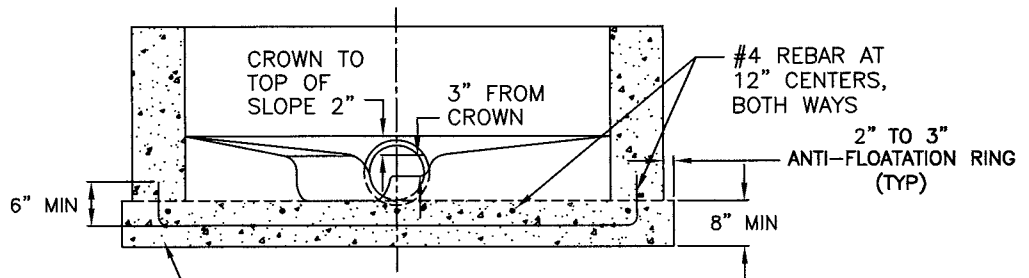
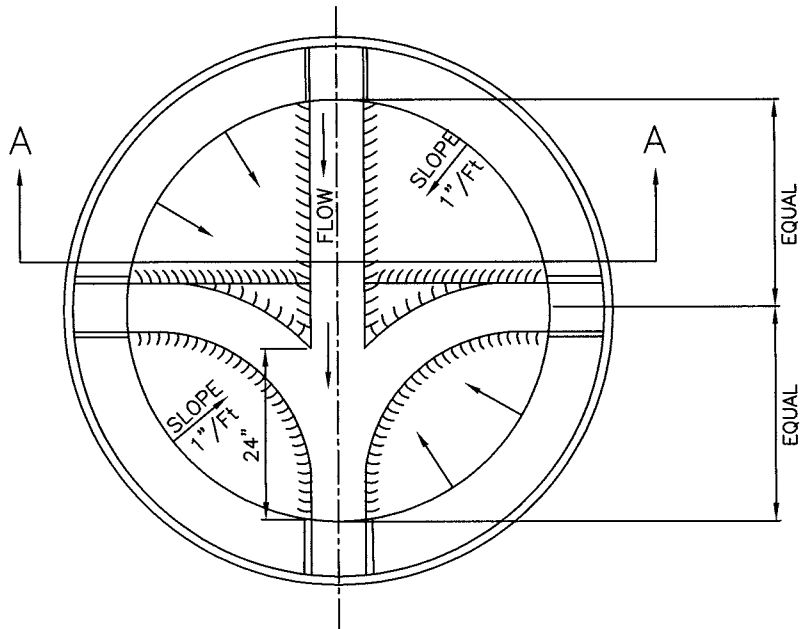

PRECAST BASE  
PLACED ON 4" MIN OF  
CRUSHED ROCK PLACED  
OVER UNDISTURBED MATERIAL

**SECTION A-A**

<b>COUNTY OF YOLO</b> PLANNING AND PUBLIC WORKS DEPARTMENT	DATE: 08/05/08
<b>MANHOLE BASE</b> <b>CAMERA CHANNEL DETAIL</b>	SHEET # 2 OF 3
<i>Parnas Kulkas</i> COUNTY ENGINEER No. C42401	28 AUG. 08 APPROVAL DATE
	DRAWING #: 7-1 NOT TO SCALE

**CAMERA CHANNEL REQUIRED FOR  
ALL 8" AND 10" LINES**

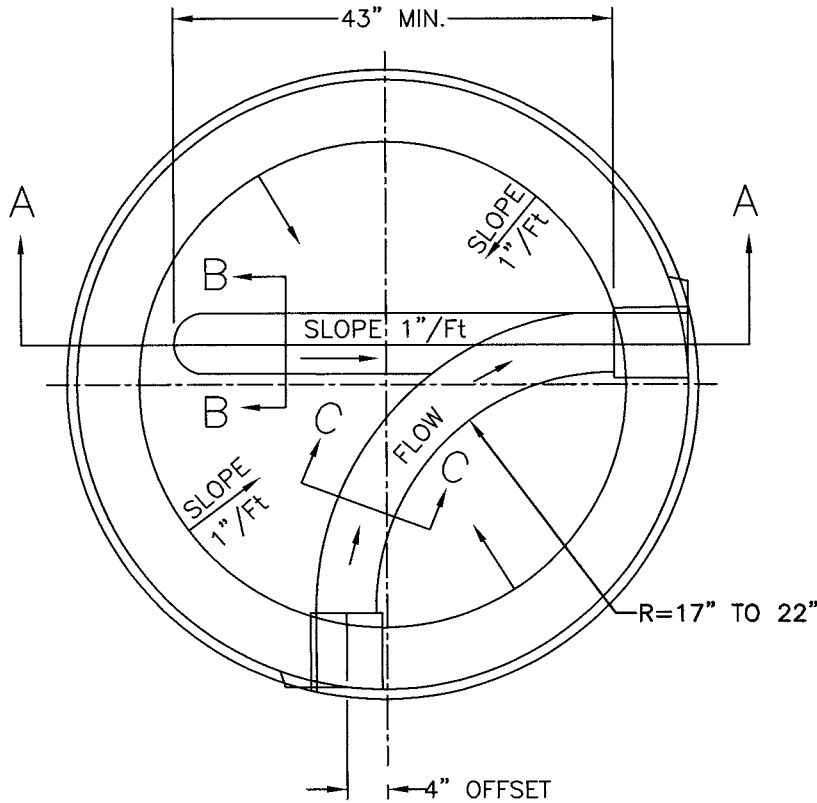

FOR 8" LINE ONLY

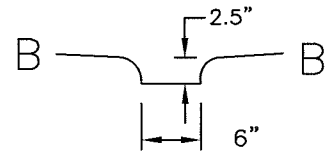

OR

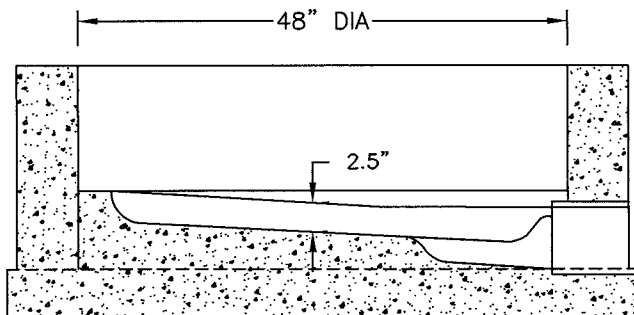
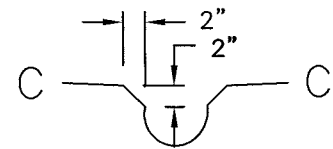

**SECTION A-A**

<b>COUNTY OF YOLO</b> PLANNING AND PUBLIC WORKS DEPARTMENT		DATE: 08/05/08
<b>MANHOLE BASE</b> <b>CAMERA CHANNEL DETAIL</b>		SHEET # 3 OF 3
<i>Panos Kallas</i> COUNTY ENGINEER No. C42401	28 AUG. 08 APPROVAL DATE	DRAWING #: 7-1 NOT TO SCALE

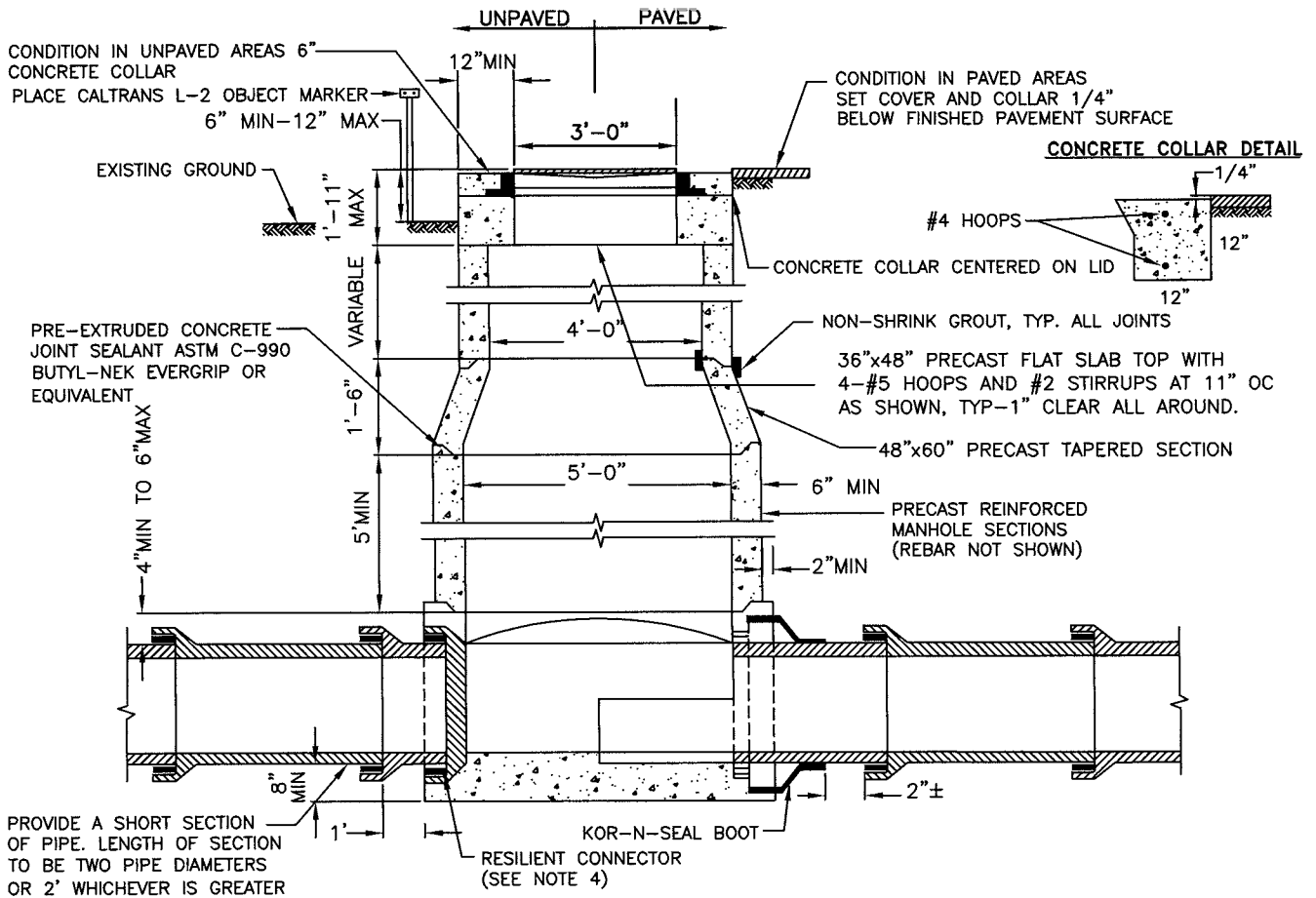

## STANDARD TYPE A 60" MANHOLE

### NOTES:

1. CLASS A CONCRETE, 6-SACK MIX SHALL BE USED FOR MANHOLE BASES.
2. PIPE SHALL STOP AT INSIDE FACE OF MANHOLE OR SHALL BE CONTINUOUS THROUGH MANHOLE. IF PIPE LAID CONTINUOUS, TOP HALF SHALL BE REMOVED AFTER BASE IS POURED.
3. JOINTS FOR THE BARREL SECTION SHALL BE TONGUE AND GROOVE, ALL JOINTS MUST BE SEALED WITH GULF STATES PRE-EXTRUDED CONCRETE JOINT SEALANT.
4. FOR PRECAST MANHOLE BASES, CONNECTION OF THE PIPE TO THE MANHOLE SHALL USE A RESILIENT CONNECTOR CONFORMING TO ASTM STANDARD C923 SUCH AS KOR-N-SEAL, A-LOK. OR EQUIVALENT.
5. ANY SERVICE SEWER ENTERING A MANHOLE SHALL BE INSTALLED WITH THE INVERT ELEVATION OF THE SERVICE PIPE MATCHING THE CROWN ELEVATION OF THE EXIT SEWER EXCEPT WHEN AN INTERNAL DROP CONNECTION IS USED.
6. BEDDING FOR PRE-CAST MANHOLE SHALL BE SELECT IMPORTED MATERIAL 1/2" OR 3/4" CRUSHED ROCK.
7. ALL MANHOLE SECTIONS TO BE FITTED WITH EXTERNAL LIFTING PINS, NO THROUGH PENETRATION HOLES ALLOWED.

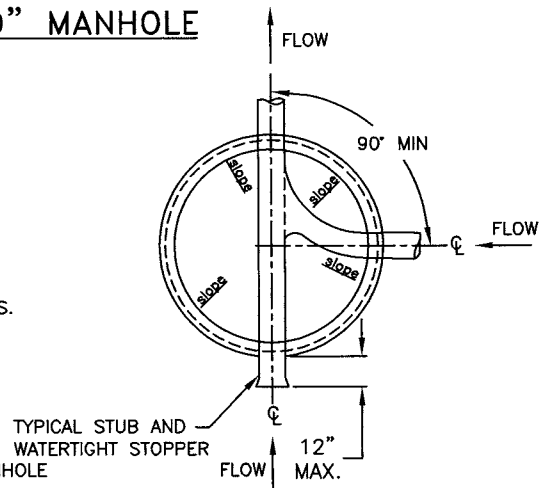

### PLAN VIEW OF 60" MANHOLE SHOWING INTERSECTING SEWERS

<b>COUNTY OF YOLO</b> PLANNING AND PUBLIC WORKS DEPARTMENT		DATE: 08/05/08
<b>STANDARD 60"</b> <b>SEWER MANHOLE (TYPE A)</b>		SHEET # 1 OF 2
<i>Pasros Kakkal</i> COUNTY ENGINEER No. C42401		DRAWING #: <b>7-2</b> NOT TO SCALE
28 AUG. 08 APPROVAL DATE		

**NOTES:**

1. PROTECTIVE COATING SHALL BE (a) T-LOCK PVC LINER, AMERON PROTECTIVE COATING, 40 MIL. (b) CCS COATING, HIGH CHEMICAL RESISTANCE EPOXY COATING BY CHEMCO SYSTEMS OF REDWOOD CITY, CA. MULTIPLE LAYER SPRAY APPLIED TO A MINIMUM FINISHED THICKNESS OF NOT LESS THAN 40 MILS. (c) RAVEN 405 EPOXY MORTAR MULTI LAYERED SPRAY APPLIED TO A MINIMUM THICKNESS OF NOT LESS THAN 60 MILS. (d) OR APPROVED EQUIVALENT.
2. BOTH PVC LINING AND PROTECTIVE COATINGS SHALL BE SPARK TESTED FOR INTEGRITY AFTER INSTALLATION.
3. PROTECTIVE COATING SHALL BE APPLIED TO MANHOLE SHELVES, UNDERSIDE OF COVER SLAB, INSIDE OF GRADE RINGS AND ALL OTHER PLACES WHERE PVC IS SHOWN ON DETAIL BELOW.
4. PVC LINER SHALL BE WHITE IN COLOR.
5. SLAB TOP TO MEET H-20 LOAD SPECIFICATIONS. WEIGHT AND LOAD SPECIFICATIONS TO BE SUBMITTED BY MANUFACTURER.

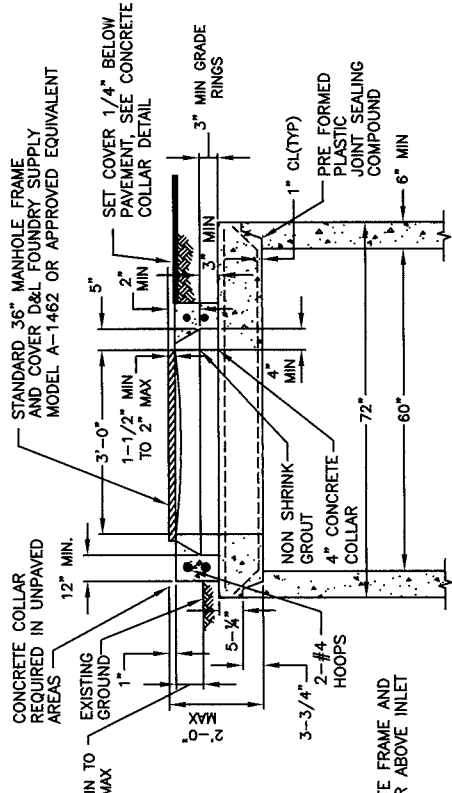
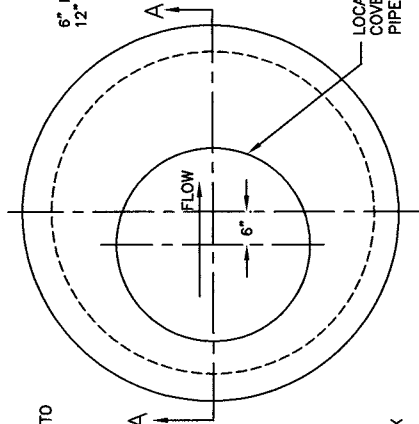

**PLAN**

**SECTION A-A**

**STANDARD SLAB TOP DETAILS**

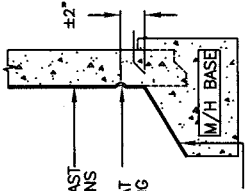

**DETAIL A**

**CONCRETE COLLAR DETAIL**

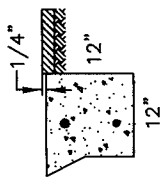

**INSTALLATION REQUIREMENTS FOR PVC SHELF LINER**

1. 30 MIL PVC SHELF LINER SHALL BE PRECUT AND PREPARED ABOVE GROUND PRIOR TO INSTALLATION WITH SAND EMBEDDED NONSKID SURFACE 1" PLUS IN FROM EDGE, ACCORDING TO PVC SHEETING MANUFACTURER'S RECOMMENDATION.
2. COAT CLEAN AND DRY CONCRETE SURFACE OF LINABOND POLYURETHANE MASTIC TO A MIN. THICKNESS OF 125 MIL. ALSO COAT CONTACT SIDE OF THE PRECUT PVC SHEETING WITH LINABOND CLA-1 ACTIVATOR ALL AS MANUFACTURED BY ALLIED COATINGS CO. OF HOLLYWOOD, CA OR EQUIVALENT (SUBMITTAL WILL BE REQUIRED).
3. ALL MATERIALS SHALL BE APPLIED ACCORDING TO MANUFACTURER'S RECOMMENDATIONS.

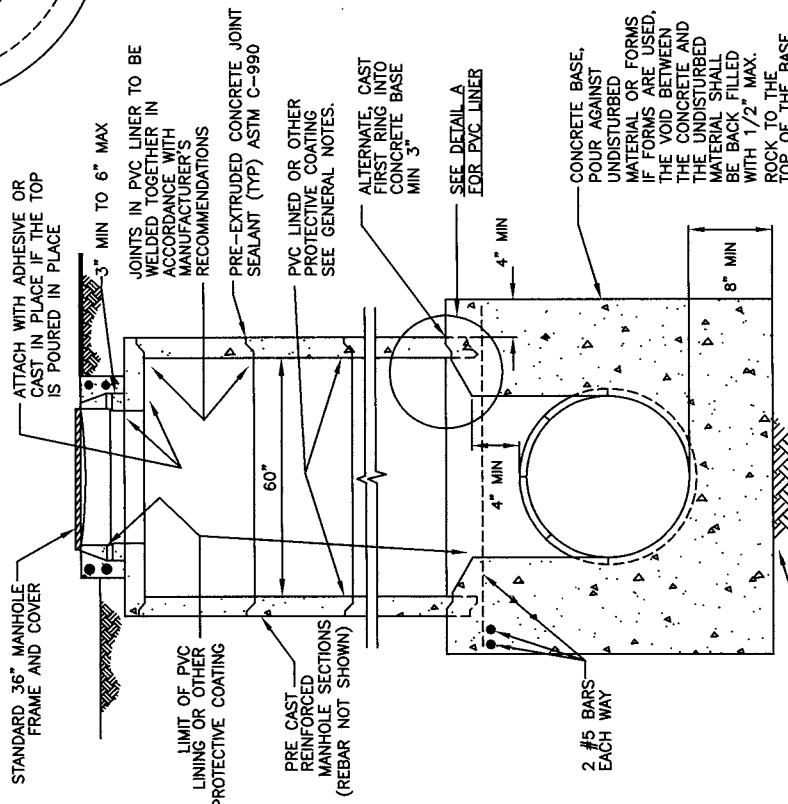

**MANHOLE DETAIL**

COUNTY OF YOLO PLANNING AND PUBLIC WORKS DEPARTMENT	DATE: 08/05/08
STANDARD 60" MANHOLE (TYPE B)	SHEET # 2 OF 2
<i>Ramos</i> COUNTY ENGINEER No. C42401	DRAWING #: 7-2 NOT TO SCALE
<i>Kallas</i> APPROVAL DATE	28 AUG 08



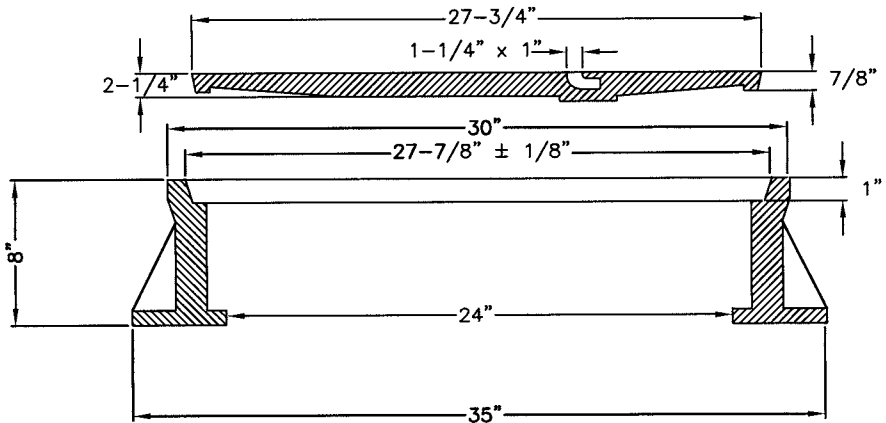
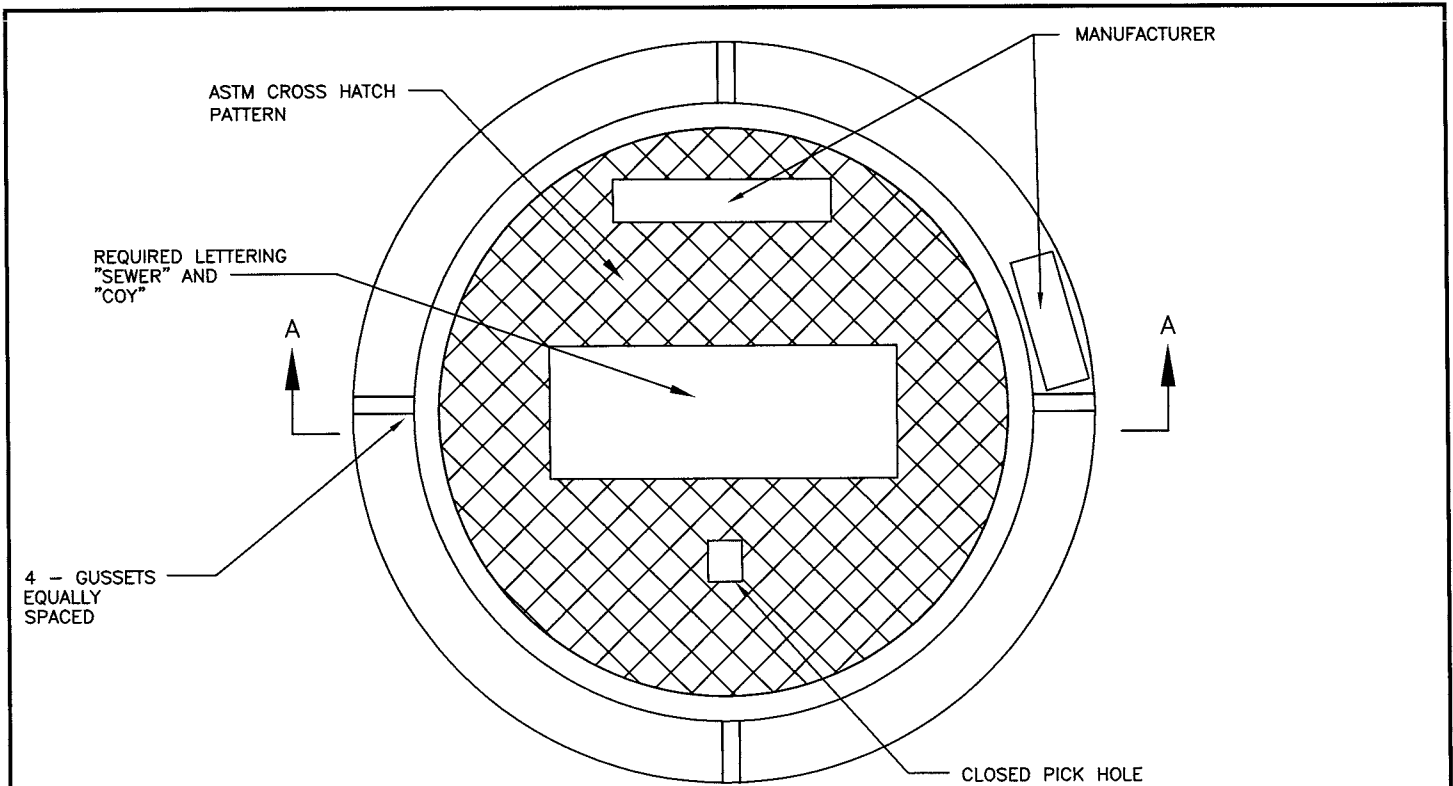

**SECTION A-A**

**NOTES:**

1. ALL CASTINGS TO CONFORM TO ASTM A48, CLASS 35B. D&L FOUNDRY A-1018, OR EQUIVALENT
2. FRAME AND COVER TO MEET H-20 LOAD SPECIFICATIONS.
3. MACHINED HORIZONTAL AND VERTICAL BEARING SURFACES NOT TO EXCEED 1/64" TOLERANCE.
4. FRAME AND COVER SHALL HAVE A COATING OF BITUMINOUS MATERIAL.
5. LOCKING COVER TYPE FRAME AND COVERS SHALL BE USED IN EASEMENT AREAS UNLESS OTHERWISE APPROVED.
6. COVER SHALL BE LABELED AS REQUIRED BY SERVICE DISTRICT. COUNTY COVERS SHALL BE DENOTED "COY".

<b>COUNTY OF YOLO</b> PLANNING AND PUBLIC WORKS DEPARTMENT		DATE: 08/05/08
<b>GRAY IRON STANDARD 24"</b> <b>MANHOLE FRAME AND COVER</b>		SHEET # 1 OF 1
<i>Panos Kakkas</i> COUNTY ENGINEER No. C42401	28 AUG 08 APPROVAL DATE	DRAWING #: <b>7-3</b> NOT TO SCALE

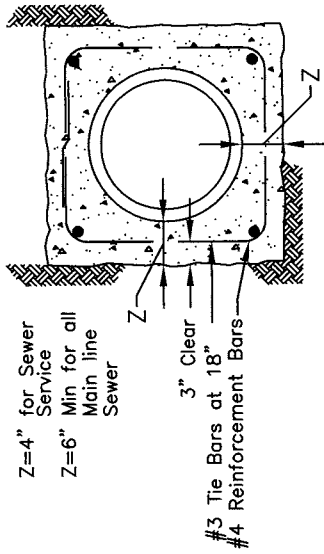

**CONCRETE ENCASEMENT**

**NOTES:**

1. Unless otherwise noted on plans bedding and initial backfill for all pipes shall be Type II.
2. Minimum depth of bedding and material under pipe bells shall be 1 1/2 inches.
3. Type III may be used only when construction conditions encountered in the field have resulted in the allowable trench width for Type II being exceeded. Written approval of the Director is necessary.
4. For all flexible (non-rigid) pipe, imported material must be used for bedding and initial backfill to 12 inches over pipe bell.
5. See Drawing 7-4 Sheet 2 for concrete dam to be installed where required due to groundwater conditions.
6. Trench backfill above initial bedding zone shall be compacted to 95% relative compaction, unless higher density is required due to site specific conditions.

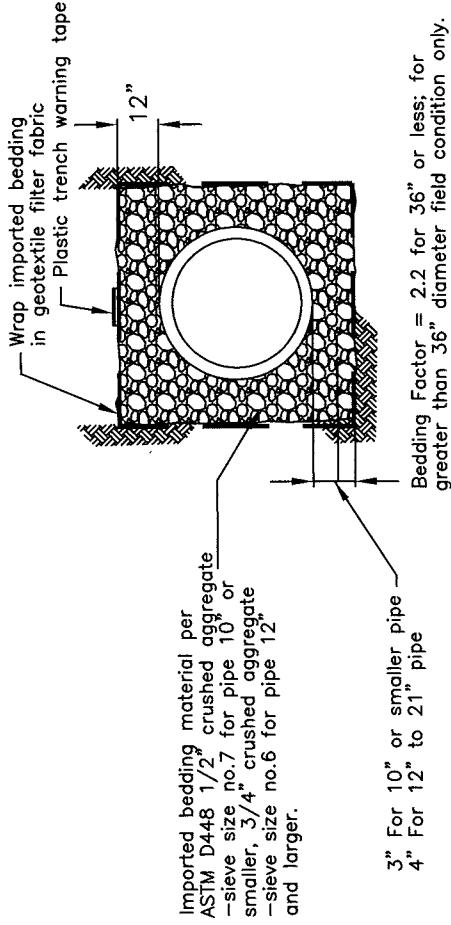

**TYPE II**

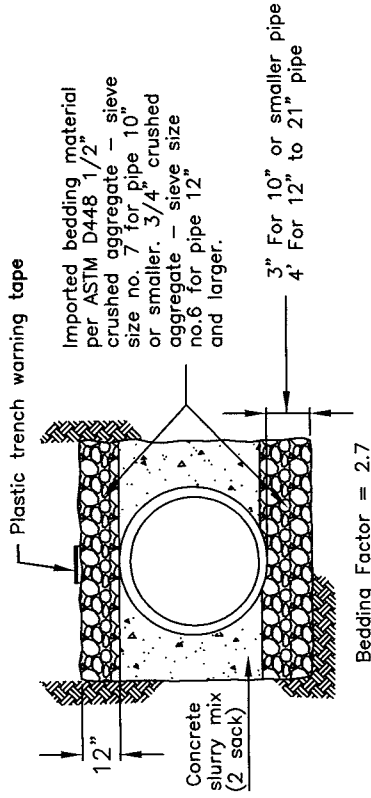

**TYPE III**  
(See Note 3)

COUNTY OF YOLO PLANNING AND PUBLIC WORKS DEPARTMENT	DATE: 08/05/08
SEWER PIPE BEDDING AND INITIAL BACKFILL	SHEET # 1 OF 1
<i>James Kollas</i> COUNTY ENGINEER No. C42401	DRAWING #: 7-4 NOT TO SCALE
<i>28 Aug. 08</i> APPROVAL DATE	

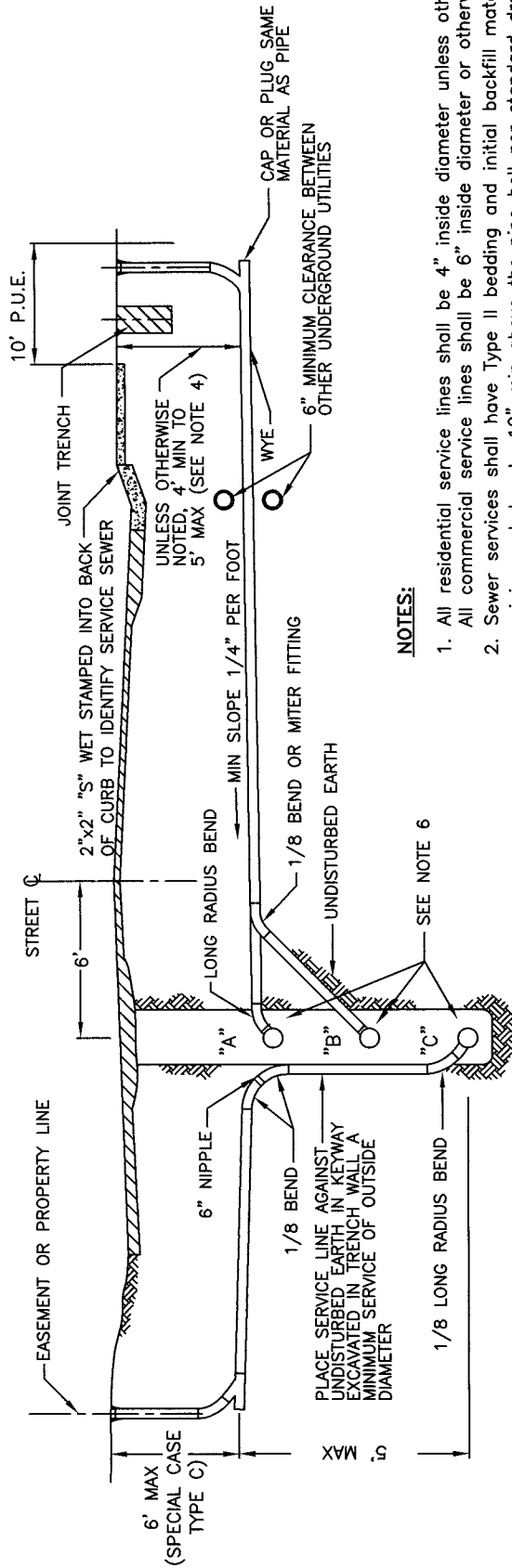

**NOTES:**

- All residential service lines shall be 4" inside diameter unless otherwise noted. All commercial service lines shall be 6" inside diameter or otherwise noted.
- Sewer services shall have Type II bedding and initial backfill material from 3" minimum below to 12" min above the pipe bell per standard drawing 7-4, Sheet 1. Contractor shall use the most appropriate type connection (A, B or C) for the particular situation.
- The standard sewer service has 4' to 5' of cover at back of sidewalk or 6' maximum for Type C. The standard cover may need to be deeper should other utilities be located in adjacent areas.
- Minimum depth of cover to be 5' and maximum 6' where joint trench (PG&E, phone, CATV) is to be installed at back of sidewalk as part of subdivision improvements.
- Place concrete 12" wide or well compacted bedding material 18" wide under the tee or wye, the fitting, and unsupported pipe. When bedding material is used, place additional bedding material to top of bend, the full width of the trench.
- Minimum specified cover at the property line shall be measured from existing ground surface or edge of adjacent roadway, whichever is lower.
- A specific elevation at the property line, when shown on the plans or designated by the engineer, shall govern.
- Miter fittings shall be maximum 45'.
- Only long radius bends shall be used.

**ELEVATIONS**

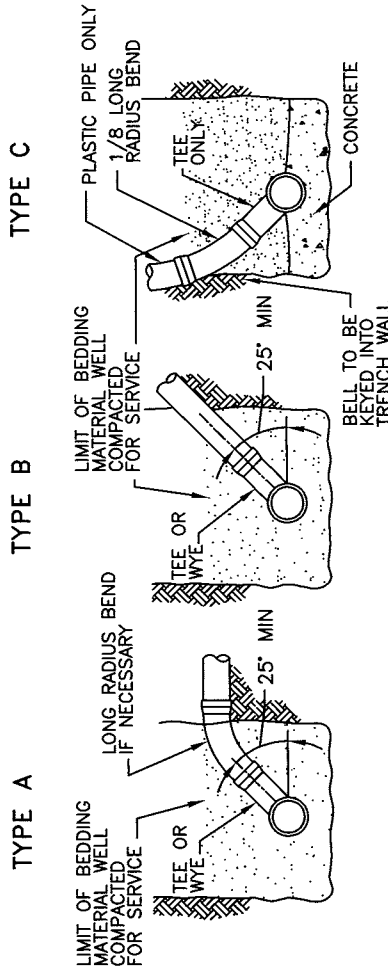

**CONNECTION DETAILS**

DATE: 08/05/08	COUNTY OF YOLO PLANNING AND PUBLIC WORKS DEPARTMENT
SHEET # 1 OF 3	SEWER SERVICES
DRAWING #: 7-5	APPROVAL DATE: 28 AUG. 08
NOT TO SCALE	COUNTY ENGINEER No. C42401

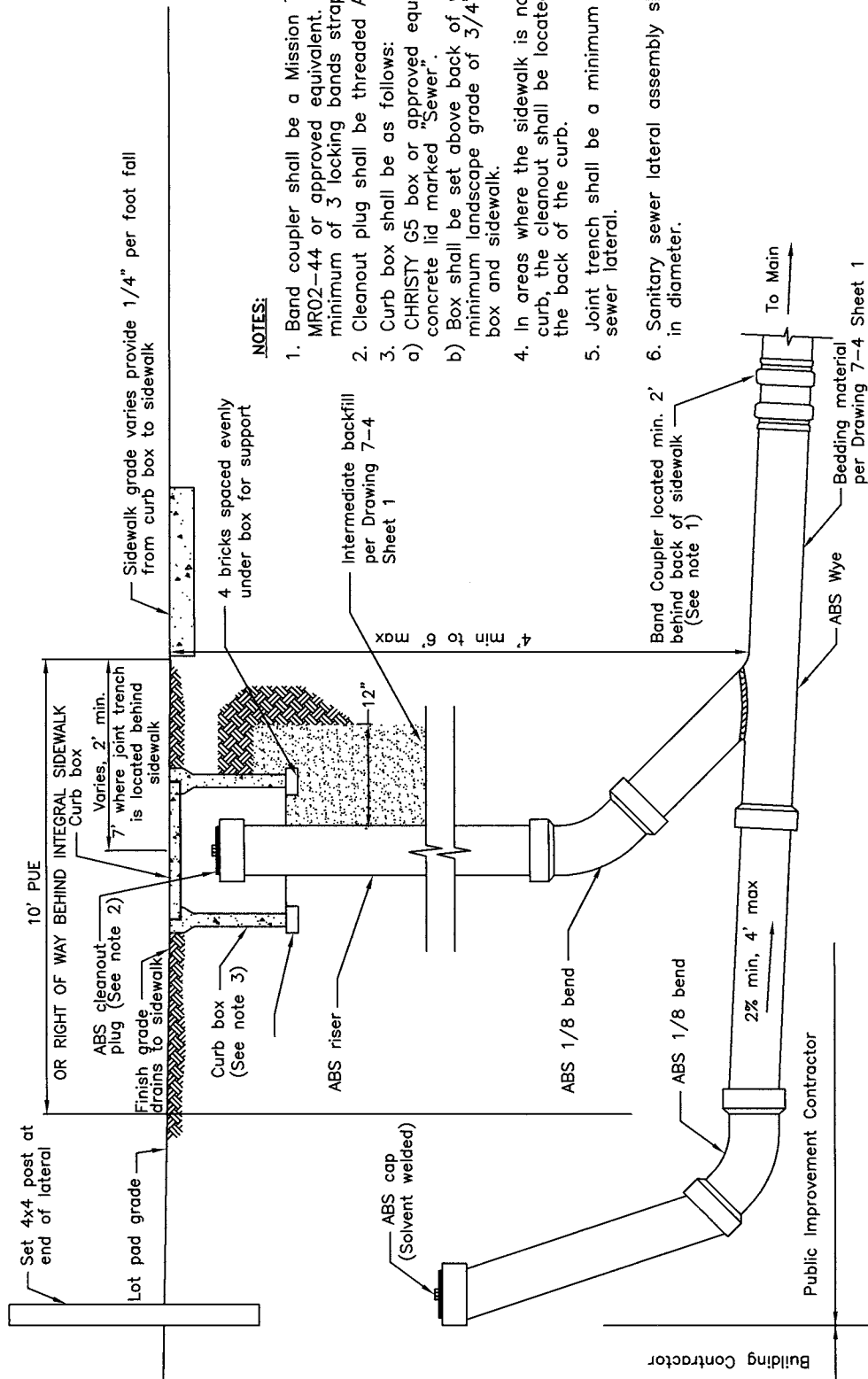

**NOTES:**

1. Band coupler shall be a Mission Transition Coupler, Model MR02-44 or approved equivalent. Band shall have a minimum of 3 locking bands straps.
2. Cleanout plug shall be threaded ABS.
3. Curb box shall be as follows:
  - a) CHRISTY G5 box or approved equivalent, with a custom concrete lid marked "Sewer".
  - b) Box shall be set above back of walk to provide minimum landscape grade of 3/4" per foot between box and sidewalk.
4. In areas where the sidewalk is not monolithic with the curb, the cleanout shall be located within 18" to 24" from the back of the curb.
5. Joint trench shall be a minimum of 6" above the sanitary sewer lateral.
6. Sanitary sewer lateral assembly shall not be less than 4" in diameter.

<b>COUNTY OF YOLO</b>		DATE: 08/05/08
PLANNING AND PUBLIC WORKS DEPARTMENT		SHEET # 2 OF 3
<b>SERVICE CLEANOUT TO GRADE</b>		DRAWING #: 7-5
<i>James Kellner</i> COUNTY ENGINEER No. C42401		APPROVAL DATE: 28 AUG. 08
NOT TO SCALE		

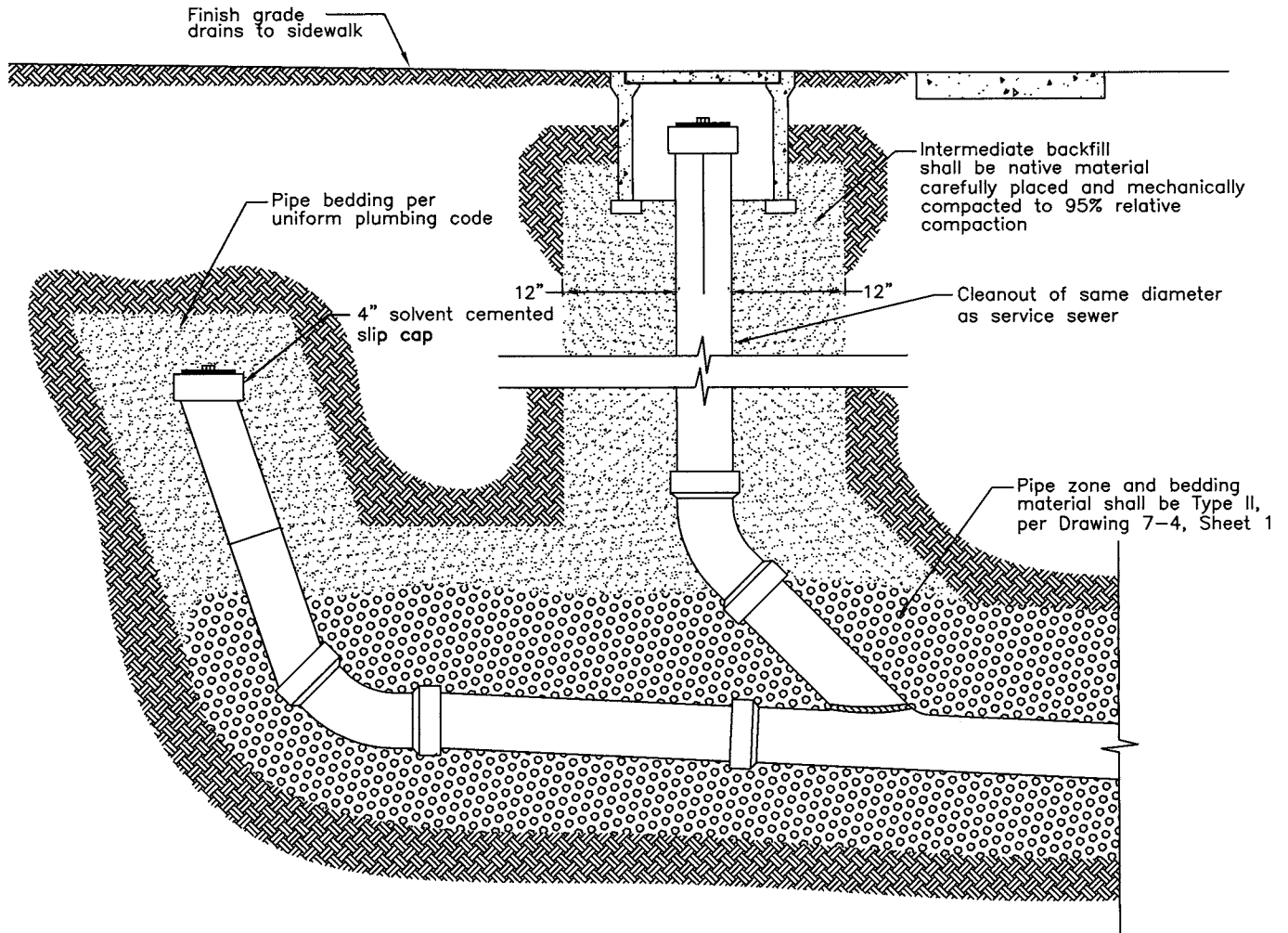

<b>COUNTY OF YOLO</b> PLANNING AND PUBLIC WORKS DEPARTMENT		DATE: 08/05/08
<b>SERVICE CLEANOUT TO GRADE</b> <b>BACKFILL REQUIREMENTS</b>		SHEET # 3 OF 3
<i>Panos Kalkas</i> COUNTY ENGINEER No. C42401		DRAWING #: <b>7-5</b> NOT TO SCALE
28 AUG. 08 APPROVAL DATE		

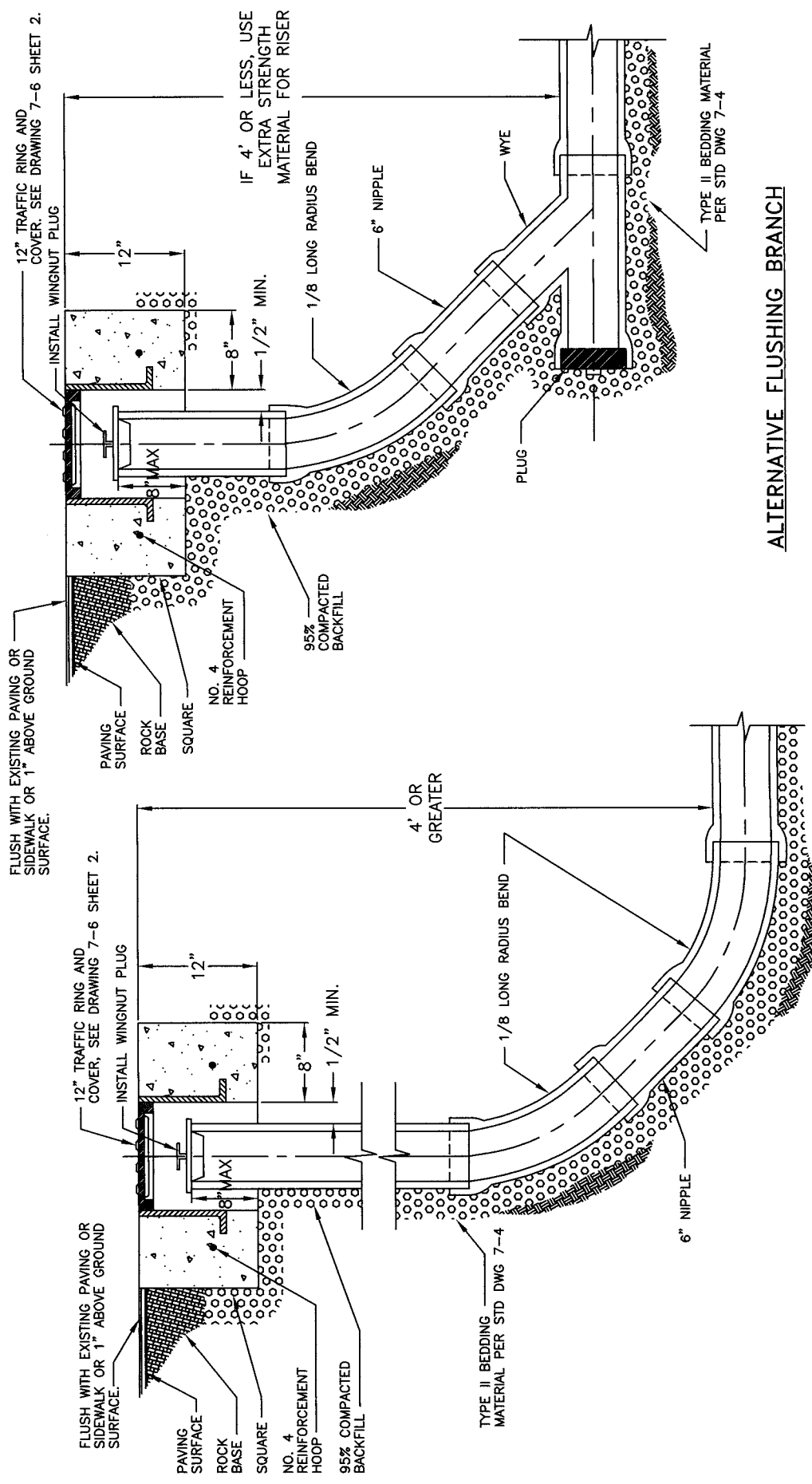

**TYPICAL FLUSHING BRANCH**

**ALTERNATIVE FLUSHING BRANCH**

**NOTES:**

1. ALL PIPE FITTINGS SHALL BE THE SAME SIZE AND MATERIAL AS THE HORIZONTAL PIPE TO WHICH THEY CONNECT.
2. JOINT SHALL BE AS SPECIFIED FOR THE TYPE OF PIPE USED.

PLANNING AND PUBLIC WORKS DEPARTMENT	COUNTY OF YOLO	DATE: 08/05/08
FLUSHING BRANCH		SHEET # 1 OF 2
<i>Pamela Kollas</i> COUNTY ENGINEER No. C42401	28 AUG. 08 APPROVAL DATE	DRAWING #: 7-6 NOT TO SCALE

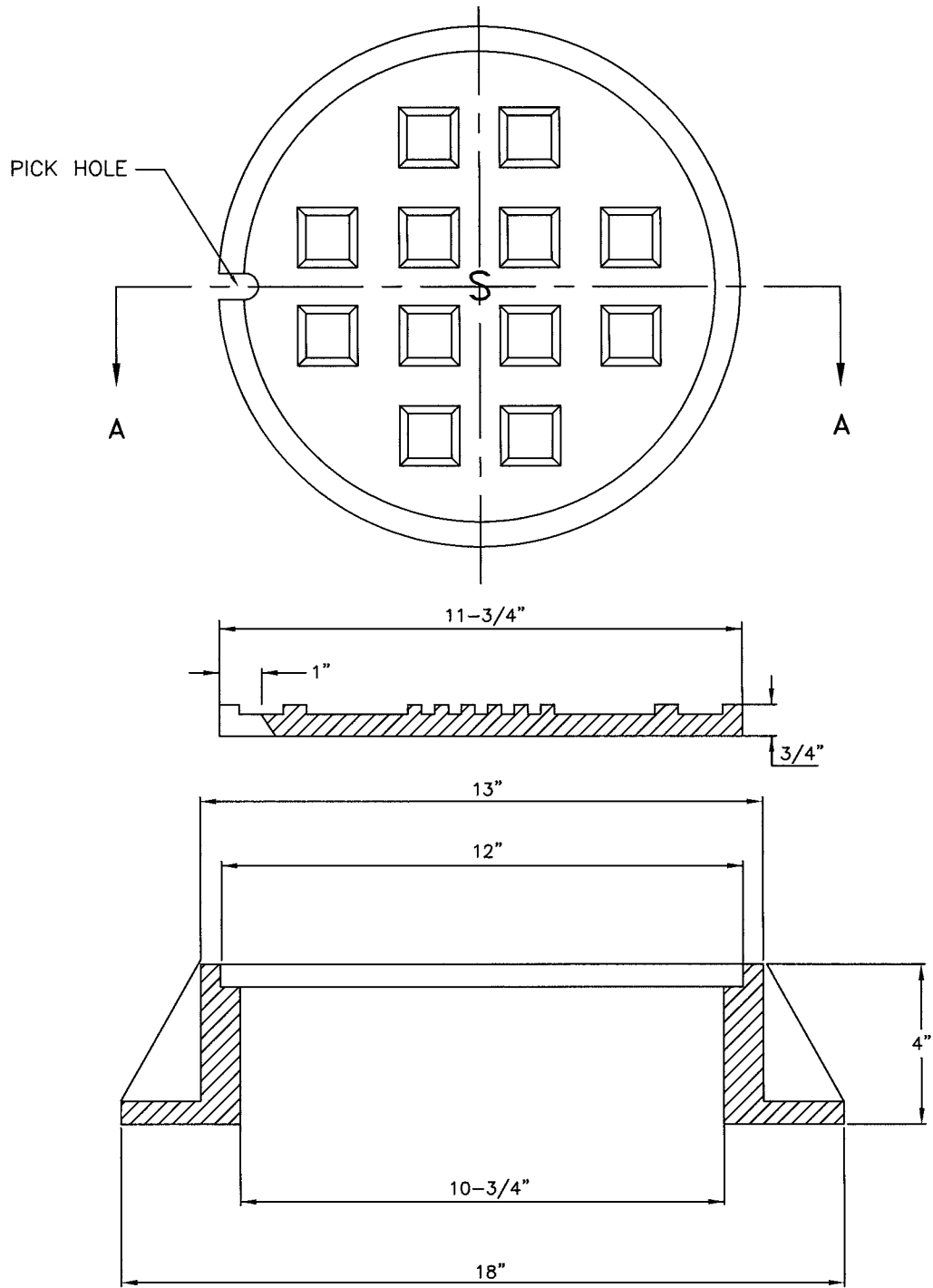

SECTION A-A

**NOTES:**

1. All materials used in manufacturing shall conform to ASTM 48, Class 35B. D&L Supply Model H-8024 or equivalent.
2. Frame and cover meets H-20 wheel loading.

<b>COUNTY OF YOLO</b> PLANNING AND PUBLIC WORKS DEPARTMENT		DATE: 08/05/08
<b>FLUSHING BRANCH</b> <b>FRAME AND COVER</b>		SHEET # 2 OF 2
<i>Parras Kalkas</i> COUNTY ENGINEER No. C42401		28 AUG 08 APPROVAL DATE
		DRAWING #: <b>7-6</b> NOT TO SCALE

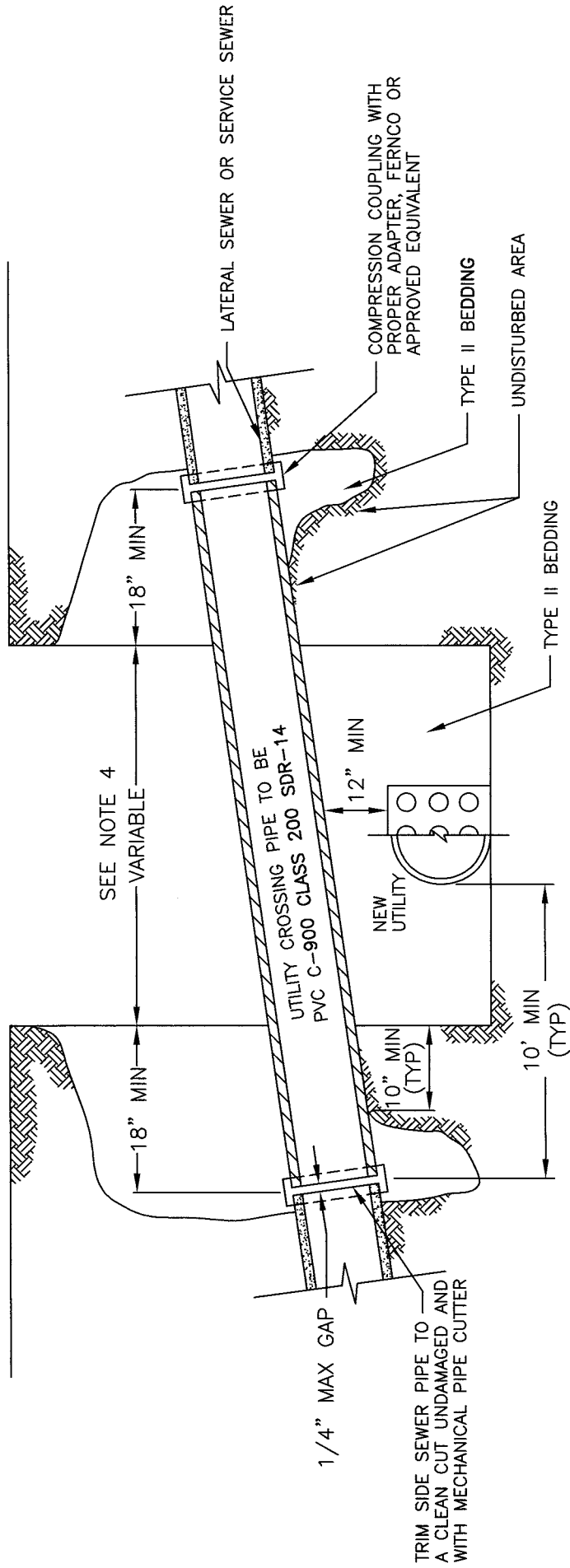

**NOTES:**

1. All lines are to be protected in place. This detail shall apply whenever the main collector or lateral sewer service is cut or damaged when new construction passes beneath these lines, and may only be used when directed to do so by the County Engineer. Detail does not apply to new water lines.
2. Inside diameter of utility crossing pipe to be the same as the pipe to which it connects.
3. Alteration of sewer grades will be permitted only after written permission has been received from the County engineer.
4. 10 feet minimum from the new utility to the newly created joint of the utility crossing pipe. Place Type II bedding to 12" above the new utility and 18" minimum each side of its center line.
5. Any new utility with 12" clearance may be required to place a compressible material (styrofoam or equivalent) between the lines.

<b>COUNTY OF YOLO</b> PLANNING AND PUBLIC WORKS DEPARTMENT	DATE: 08/05/08
UTILITY CROSSING	SHEET # 1 OF 2
<i>James Kalkas</i> COUNTY ENGINEER NO. C-42401	DRAWING #: 7-7 NOT TO SCALE
<i>28 Aug. 08</i> APPROVAL DATE	



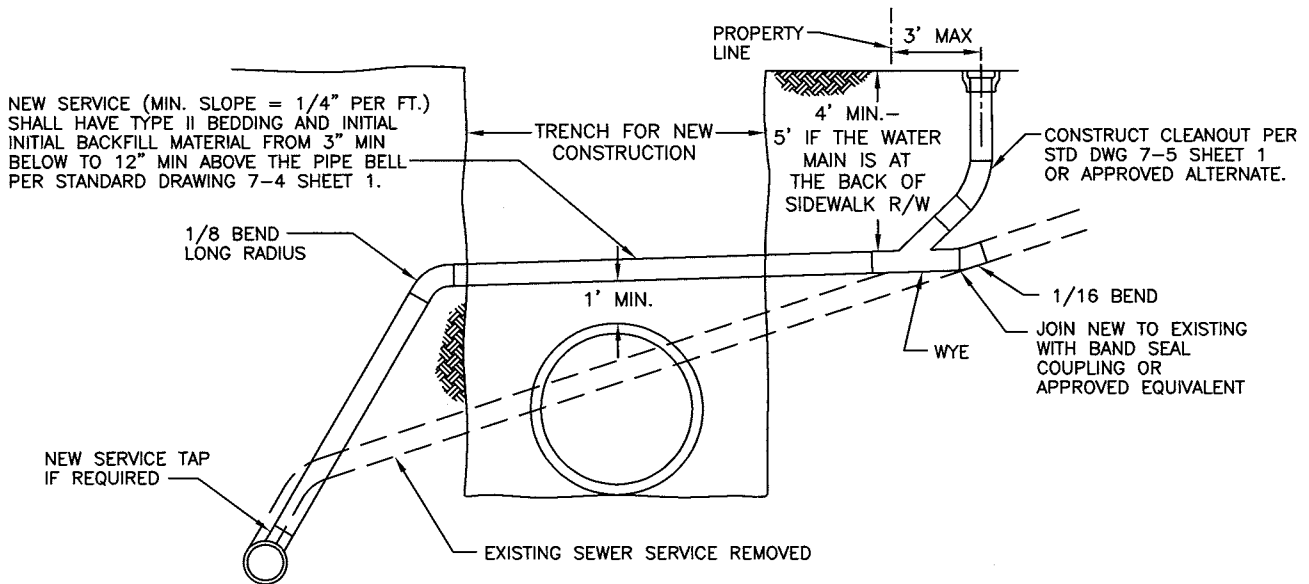

**A. SEWER SERVICE RELOCATION OPTION OVER NEW CONSTRUCTION**  
(WATER MAIN UNDER NOT ALLOWED)

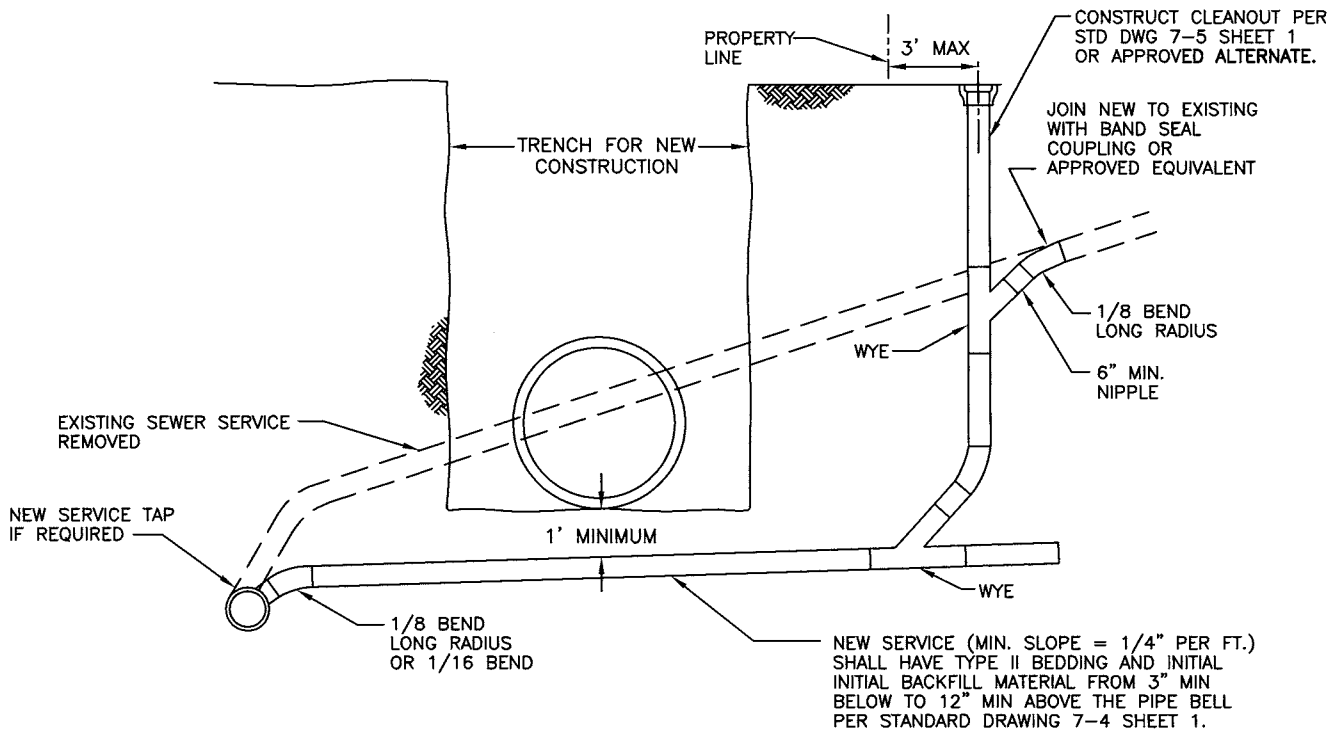

**B. SEWER SERVICE RELOCATION OPTION UNDER NEW CONSTRUCTION**  
(WATER MAIN OVER SEWER SERVICE)

**NOTE:**

IF NEITHER OF THESE OPTIONS IS AVAILABLE, THE ELEVATION OF THE NEW FACILITY WILL NEED TO BE ADJUSTED TO ACCOMMODATE ONE OF THESE OPTIONS.

<b>COUNTY OF YOLO</b> PLANNING AND PUBLIC WORKS DEPARTMENT		DATE: 08/05/08
<b>UTILITY CROSSING</b>		SHEET # 2 OF 2
<i>Panos Kaklas</i> COUNTY ENGINEER No. C42401		28 AUG 08 APPROVAL DATE
		DRAWING #: 7-7 NOT TO SCALE

## SECTION 8

### WATER SYSTEMS

<b>CONTENTS</b>	<b>Page</b>
8-1 Introduction.....	8-1
8-2 Intent Of Water System Improvement Standards .....	8-1
8-3 Definitions .....	8-1
8-4 Applicable Standards .....	8-1
8-5 Water System Master Plan.....	8-2
8-6 Improvement Plan Submittal .....	8-2
8-7 Approval Of Improvement Plans .....	8-2
8-8 Improvement Plan Revision.....	8-3
8-9 Connection Permits And Fees.....	8-3
8-10 Water Quality.....	8-3
8-11 Water Pressure .....	8-3
8-12 Water Demand .....	8-3
8-13 Fire Flows .....	8-4
8-14 Wells, Treatment Plant And Storage Facility Design .....	8-5
8-15 Distribution Main Design .....	8-5
A. Distribution Main Design Plan Requirements .....	8-5
B. Distribution Main Location.....	8-6
C. Distribution Main Layout and Sizing .....	8-6
D. Distribution Main Pipe Restraint .....	8-6
E. Type of Distribution Main Pipe and Pipe Deflection .....	8-7
F. Distribution Main Valves.....	8-7
8-16 Water System Appurtenances .....	8-7
A. Fire Hydrants and Blow-off Assemblies.....	8-7
B. Water Service Lines.....	8-8
C. Water Meters.....	8-8
D. Fire Department Connection.....	8-8
E. Back-Flow Devices.....	8-8
F. Air Release/Vacuum Valve Assemblies .....	8-9
G. Polyethylene Wrapping.....	8-9
H. Tracer Wire .....	8-9
I. Marking Tape.....	8-9
J. Markers .....	8-9
K. Water Sampling Stations .....	8-9
8-17 Recycled Water And Non-Potable Water Transmission Mains And Distribution Mains.....	8-10
8-18 Testing Procedures.....	8-10

<b>CONTENTS</b>		<b>Page</b>
A.	Pressure Test.....	8-10
B.	Chlorine Disinfection.....	8-10
C.	Water Quality Testing.....	8-11
D.	Continuity Testing .....	8-11
E.	Corrosion Testing .....	8-11
8-19	Record Plans .....	8-11

## **SECTION 8**

### **WATER SYSTEMS**

#### **8-1 INTRODUCTION**

These Improvement Standards shall apply to water supply and distribution facilities to be maintained by a CSA Service Area (CSA) providing extended water services. These Standards are minimum criteria. The County Engineer may permit modifications or may require higher standards where unusual conditions are encountered. These Standards shall also apply to any privately owned and maintained system serving 4 or more residential units or any commercial or industrial uses. Where water supply and distribution facilities are to be maintained by a Community Service District or a City, the standards of the District or City shall govern the design and construction of water supply and distribution facilities.

#### **8-2 INTENT OF WATER SYSTEM IMPROVEMENT STANDARDS**

The intent of these water system improvement standards is to provide water systems that reliably and safely convey water at a reasonable capital cost and with minimum operation and maintenance costs.

#### **8-3 DEFINITIONS**

When the following terms or titles are used in these water system improvement standards, or in any document or instrument where these standards govern, the intent and meaning shall be as herein defined:

- AWWA - American Water Works Association.
- Raw Water – Untreated, non-potable water for irrigation use only.
- Recycled Water – Reclaimed treated wastewater, non-potable water for irrigation use only.
- Water System - Refers to potable, raw water, and recycled (reclaimed) water systems.

#### **8-4 APPLICABLE STANDARDS**

The most current requirements of the following agencies, regulations and standards shall apply to the design of water systems. In case of conflict between the requirements of these water system improvement standards and the agencies and documents listed below, the more stringent requirement shall govern.

- United States Environmental Protection Agency (EPA) Drinking Water Regulations.
- Laws, regulations, codes, and standards of the State of California relating to domestic water.
- Title 17, Chapter 5, California Code of Regulations, regarding cross-connections and backflow prevention.
- Title 22, Division 4, Chapter 16, California Code of Regulations, regarding California Waterworks Standards
- Permit and regulatory requirements of the State of California Department of Health Services.
- Yolo County Code Title 6, Chapter 8, Water Quality.
- Rules and regulations of Yolo County Health Department.
- General Order No. 103 of the California Public Utilities Commission.
- Uniform Fire Code.
- Latest Edition of the American Water Works Association (AWWA) standards.

### **8-5 WATER SYSTEM MASTER PLAN**

The Developer shall provide a Water System Master Plan for the approval of the County Engineer that addresses water supply and reliability issues, and demonstrates how adequate daily service and fire protection will be provided for the project.

The Master Plan shall include, at a minimum:

1. A copy of the water assessment prepared for the project in accordance with the California Water Code Section 10910, et. seq.
2. The anticipated growth of the water system over a projected period of at least ten years in terms of the population and number and type of residential, commercial, and industrial service connections to be served by the water system.
3. Estimates of the amount of water needed to meet the total annual demand over the projected ten-year growth period (projected system demand). Methods, assumptions, and calculations used to estimate the projected system demand shall be included.
4. A map and description of the entire existing and proposed service area, showing:
  - a. The location of each water source, including wells that are abandoned, out-of-service, destroyed, standby, or inactive;
  - b. Any valid water rights owned by the system for surface water sources, including information on any limitations or restrictions of those rights;
  - c. For a groundwater aquifer, the groundwater levels and drawdown patterns;
  - d. Permits or approvals for groundwater extraction if pumping from an adjudicated groundwater basin;
  - e. Existing and planned source pumping capability and distribution storage capacity for the system
  - f. The calculated sustained well yields of existing wells if groundwater sources are used; as a whole and for each pressure zone;
  - g. Permits, if required, for any waters proposed for use to offset potable water demand; and
  - h. A Source Water Assessment for each potable water source.
5. Distribution system piping, pressure zones, hydro-pneumatic tanks, and reservoirs;
6. Valves, sample taps, flow meters, unmetred service connections, and other system appurtenances;
7. Conveyance facilities;
8. Provisions for backup power to operate facilities during extended power outages common in rural areas;
9. Any flood plains in the projected service area; and
10. The 100 year flood or highest recorded flood level, whichever is higher.

### **8-6 IMPROVEMENT PLAN SUBMITTAL**

Improvement plans shall meet the requirements of these Improvement Standards, to the satisfaction of the County Engineer.

### **8-7 APPROVAL OF IMPROVEMENT PLANS**

The County Engineer will approve water system improvements concurrently with any street, sewer, storm drainage or other improvements shown on the Improvement Plans. The following must occur before the plans can be approved:

- The local Fire District must approve the improvement plans as to fire flow pressure, fire hydrant spacing, and fire hydrant valve outlet configuration and sizes.

- The location of all wells in use and all abandoned wells must be shown on the improvement plans. Wells must be properly abandoned in accordance with permits issued by the Yolo County Health Department. Copies of well abandonment permits for all abandoned wells must be provided to the County Engineer prior to final acceptance of any public improvements.

### **8-8 IMPROVEMENT PLAN REVISION**

All plan revisions that affect a water system to be maintained and operated by the County shall be approved and signed by the County Engineer prior to construction.

### **8-9 CONNECTION PERMITS AND FEES**

A water connection and/or encroachment permit shall be obtained for each new connection to the water system. Contact Yolo County Department of Planning and Public Works for information concerning fees.

### **8-10 WATER QUALITY**

The quality of the potable water supplied or delivered into any portions of a public water system shall conform to the applicable federal standards and State Department of Health Services Drinking Water Standards.

### **8-11 WATER PRESSURE**

Water distribution systems shall be designed so that normal operating pressures at service connections to the distribution system are not less than 45 pounds per square inch (psi) and not more than 100 psi. During periods of maximum day domestic demand plus fire demand, the pressure shall not be less than 20 psi at the location of the fire flow and no less than 5 psi anywhere in the distribution system.

### **8-12 WATER DEMAND**

Determination of design flow rates required for a specific land use category shall consider maximum day domestic demands occurring in conjunction with an emergency fire flow demand. For design of the water supply and distribution system, the unit demand factors shall be assumed in accordance with Table 8-1 below, in consultation with the County Engineer. Small and/or remote systems may require more stringent standards, as determined by the County Engineer.

To provide for projected growth, the County Engineer may require that distribution mains be upsized in accordance with approved Master Water Plans.

<b>TABLE 8-1 WATER DEMAND FACTORS</b>	
<b>Land Use Category</b>	<b>Average Day Water Demand Factors</b>
Single Family Residential (<6 Dwelling Units/Acre)	728 gpd/dwelling unit
Multi Family (>6 to 12 Dwelling Units/Acre)	521 gpd/dwelling unit
Commercial/Retail	2,598 gpd/ac
Business Professional/Light Industrial	2,598 gpd/ac
Industrial	2,562 gpd/ac
Railroad Yard	109 gpd/ac
Elementary Schools	3,454 gpd/ac
High Schools	4,068 gpd/ac
Public (Fire Station, etc)	1,780 gpd/ac
Park/Recreation	2,988 gpd/ac

The average day demand to maximum day demand peaking factor shall be 2.0. The maximum day demand to peak hour demand peaking factor shall be 1.7 (3.4 average day to peak hour).

**8-13 FIRE FLOWS**

Required fire flows shall be determined by the California Fire Code, the fire protection district having jurisdiction, and the County of Yolo. Minimum fire flows shall not be less than shown in Table 8-2 following, with a 2-hour duration:

<b>TABLE 8-2 FIRE FLOWS</b>	
<b>Development Category</b>	<b>Fire Flow, Gallons per Minute</b>
Single-Family Residential	1,500
Light Commercial	2,500
Planned Unit and Multiple Dwelling Areas	2,500
Central Business District	3,500
Industrial/Higher Value Buildings	3,500

### **8-14 WELLS, TREATMENT PLANT AND STORAGE FACILITY DESIGN**

Where a CSA is proposed to provide wastewater treatment services, the Developer shall be responsible for all costs to create the CSA, prepare an Engineer's Report to estimate assessments, and provide engineered plans for the wells, treatment plant, and storage facility design. Such plans shall be prepared by an engineering firm retained by the Developer that 1.) has demonstrated expertise and experience designing municipal water supply, treatment, and storage systems, and 2.) is approved by the County Engineer prior to the commencement of design work.

In general, all developments must provide a minimum of two (2) demonstrated sources of water. The water supply and treatment plant shall include, but is not limited to, wells, storage tanks, pumps, hydropneumatic tanks, chemical storage and treatment equipment, backup power with automatic transfer switches, toilet facilities, safety eyewashes, conditioned office space for operations and maintenance personnel and control equipment, lighting, landscaping, landscape irrigation, and security fencing. Automatic backup power systems to operate the water system shall be provided, using natural gas where available, or propane (LPG). Operational systems shall include telemetry and SCADA systems to allow remote monitoring and operations.

Site selection for the above mentioned facilities shall be approved by the County Engineer and meet the requirements of the Yolo County Environmental Health Department and the State Department of Health Services.

### **8-15 DISTRIBUTION MAIN DESIGN**

Sizing of distribution mains shall be such that the normal pressures stated in Section 8-11 and the minimum requirements as stated below for distribution main spacing and sizing are maintained. The Hazen-Williams formula shall be used in the hydraulic study of the system, using a "C" value of 125 for polyvinyl chloride pipe and cement-lined ductile iron pipe.

A Hardy-Cross hydraulic analysis of any proposed distribution system shall be provided to the County Engineer. In design of the system, the maximum assumed delivery from any hydrant shall be assumed to be limited to 1,500 gallons per minute.

- A. Distribution Main Design Plan Requirements:** Plans for the construction of water mains whether in conjunction with other improvements or for a water project only, shall conform to the following standards, as well as other provisions contained in these Improvement Standards.
1. The distribution main shall be shown on the Street Plan and Profile sheets, and for non-street areas on separate plan and profile sheets as required.
  2. Details of distribution mains crossing within 15" of other utilities, or unusual alignments, will be provided if deemed necessary by the County Engineer.
  3. A sand bedding shall be provided around all water mains (6 inches minimum all directions), regardless of pipe material type. If existing soil is too porous to hold sand, a geotextile fabric placed on the trench bottom and covered with 6 inches of sand may be used. Bedding and backfill shall be compacted to 95% relative compaction. Grooves shall be dug in the pipe bedding to accommodate pipe bells, fittings, and joints so that the pipe is continuously supported by the bedding material.
  4. Stationing for all fittings, shut off valves, air release/vacuum valves, and in line blow-off valves shall be called-out in the profile view of the improvement plan sheets. Elevations shall be called-out at all changes in pipe elevation. Horizontal alignment changes shall be called out on the plan view.
  5. Commercial, industrial, and apartment Improvement Plans with a water easement shall have a note that states, "Utilities may not be located within water easement(s) except if the utility crosses the water easement within 20 degrees of perpendicular to the water main."



- B. Distribution Main Location:** All water distribution mains shall be installed within public rights-of-way or easements.
1. In new subdivisions, the centerline of the water main shall be located six feet north or west of street centerlines within minor and primary streets. If a street loops 180 degrees or more it is not necessary for the water main to cross to the other side of the street to meet this requirement.
  2. If it is necessary to install a water distribution main within a private road, the water easement shall be the width of the paving plus one foot each side. Water easements over water distribution mains located on commercial, industrial, or apartment properties shall have a minimum width of 15 feet. The water main shall be centered in the easement.
  3. If it is necessary to install a water distribution main within a landscape corridor, then no trees shall be planted within five feet of the water main. The water distribution main shall be centered within a 15 foot wide water easement. The landscape plans for the corridor shall be submitted prior to approval of the improvement plans.
  4. If a water distribution main is required to be installed between residential homes, the pipe material shall be Class 350 Ductile Iron Pipe, and a 6 inch wide warning tape shall be placed on the backfill. The center of the main shall be centered within a 15 foot wide easement.
  5. Ten (10) feet shall be the minimum horizontal distance between the exterior surfaces of parallel water distribution and sanitary sewer mains or recycled water mains. The water distribution main shall be higher than the sewer main or recycled water main. Separation may be less if it is accordance with California State Department of Health Services requirements and approved by the County Engineer.
  6. On all utility crossings, the water distribution main shall maintain a separation or clearance of at least 12-inches (1 foot) from the utility.
  7. When crossing over a sanitary sewer force main, it shall be specified that the water distribution main be installed a minimum of three (3) feet above the sewer line and be ductile iron.
  8. Water distribution mains to be installed in public right-of-ways or easements not conforming to the items above shall be approved by the County Engineer in consultation with other affected utility providers.
- C. Distribution Main Layout and Sizing:** The distribution system, whenever possible, shall be in grid form so that pressures throughout the system tend to become equalized under varying rates and locations of maximum demand, and to provide system redundancy. The minimum pressures and flows as specified shall govern design of the system. The following conditions are to be considered for the distribution system design:
1. The minimum pipe size shall be eight inches inside diameter.
  2. Where distribution mains are installed in an arterial street, dual mains (one pipeline on each side of the street) may be required.
  3. Mains shall maintain a minimum cover of 36-inches, and when not avoiding other utilities mains shall have a maximum depth of 60-inches, unless otherwise specified by the County Engineer. Both distances shall be measured from finish grade. Mains shall be located a minimum of 24" from the subgrade of the street pavement section.
- D. Distribution Main Pipe Restraint:** Pipes shall be restrained from movement as a result of thrust on the fittings and valves of the water system. Thrust restraint for bends and tees may be accomplished with thrust blocks as shown in Standard Drawing 8-3, or by means of pipe joint restraining devices such as Star Pipe Products, Stargrip® Series 4000, or equivalent. Thrust blocks must be poured against undisturbed soil.

- E. Type of Distribution Main Pipe and Pipe Deflection:** Water mains up to 12” diameter shall be Class 200 AWWA C900 Polyvinyl Chloride. Ductile iron pipe (DIP) for crossings shall be manufactured to conform to ANSI/AWWA C-150/21.50 thickness design of ductile iron pipe and to "Ductile Iron Pipe Centrifugally Cast in Metal Molds or Sand-Lined Molds for Water and Other Liquids" (ANSI/AWWA C-151/A21.51) and shall be cement-mortar lined in accordance with the standard for "Cement-Mortar Lining for Ductile Iron Pipe and Fittings for Water" (ANSI/AWWA C-104/A21.4). All DIP shall be encased in clear, 4-mil HDPE sleeves, installed in accordance with these Improvement Standards and the standard for "Polyethylene Encasement for Ductile-Iron Piping for Water and Other Liquids" (ANSI/AWWA C-105/A21.5).

Pipe curvature induced due to bending PVC pipe shall exceed 140% of the manufacturer's minimum recommended bending radius. Bending of Polyvinyl Chloride pipe shall not exceed the limits described in Standard Drawing 8-9.

- F. Distribution Main Valves:** Valve clusters shall be placed at all pipe intersections with a valve on each leg of the main. Gate valves shall be used on 12” diameter and smaller mains. Butterfly valves shall be used on all larger size mains. Valves shall be placed in between main line intersections at intervals of 500 feet between valves.

#### **8-16 WATER SYSTEM APPURTENANCES**

Water system appurtenances include fire hydrants, water service lines, water meters, detector check valves, and back-flow devices.

- A. Fire Hydrants and Blow-off Assemblies:** Fire hydrants and blow-off assemblies shall be located as follows:
1. Fire hydrants shall be connected to distribution mains only.
  2. Fire hydrants shall be placed at street intersections wherever possible, and located to minimize the hazard of damage by traffic. They shall have a maximum normal spacing of 500 feet measured along the street frontage in residential developments, 300 feet in commercial developments, or as otherwise approved by the local Fire District. Hydrants located at intersections shall be installed at the curb return. Within residential areas, all other hydrants shall be located on property lines between lots. See Standard Drawing 8-2 and typical installation details.
  3. The minimum size lateral serving a fire hydrant shall be six inches in diameter provided the distance from the nearest intersecting main to the hydrant shall not be greater than 50 feet if fire flow requirements are 1500 gpm, or 10 feet if fire flow requirements are greater than 1500 gpm. The lateral pipeline connecting the hydrant and the main shall have a gate valve flanged to the main.
  4. A fire hydrant or four (4)-inch blow-off assembly shall be installed on all permanent dead-end runs including cul-de-sacs. If the local Fire District requires a hydrant at the end of a dead-end run, then a 4-inch Blow-off assembly will not be allowed. Two-inch Blow-off valves shall be used if dead-end runs are temporary. Wherever possible, the blow-off assemblies shall be installed in the street right-of-way, a minimum distance of three (3) feet from the lip of gutter, or behind the sidewalk. In no case shall the location be such that there is a possibility of siphoning into the distribution system. See Standard Drawings 8-12, and 8-13 for specifications and typical installation details.

- B. Water Service Lines:** Service lines from the water distribution main to the property line or edge of easement shall always be installed at the time the main is constructed. Services from mains installed in private roads shall extend one foot beyond the edge of the pavement, sidewalk, curb and gutter. Service line criteria shall be as follows:
1. In all new subdivisions, the service line shall be located 5 feet from the side property line, and the meter box assembly shall be located outside of the flowline of any proposed sideyard swales or areas subject to ponding.
  2. The minimum size of a new residential service line and meter shall be one and one-half inches (1-1/2") in diameter. Schools, commercial, industrial, or multiple-family units with higher water demand shall be provided with larger service lines, subject to approval of the County Engineer. All services shall be installed with a corporation stop at the main and valve at the property line. The property line valve shall be the angle meter stop (2" and smaller services) or a gate valve (services larger than 2") at the water meter whenever possible.
  3. The Contractor shall make all water service taps into existing mains upon application for a permit and payment of the required fees. A note to this effect shall be placed on the plan sheet which details the area that requires such tapping. Application should be made to County of Yolo Planning and Public Works Department and the required fees paid at least five (5) days in advance of the time the tap is desired. The Contractor shall perform all work subject to inspection and acceptance by the County Engineer.
  4. All services up to two inches in diameter shall be Type K soft copper. All larger services shall be the same material as the water main. No joints shall be allowed in service lines.
  5. The location of all water services shall be permanently marked with a 2" tall "W" wet-stamped into the face of the concrete curb.
- C. Water Meters:** The developer shall provide meters and a complete automated meter reading system (meters, radio-read transmitters, remote transceivers, software, etc). Water meters shall be installed on all residential, commercial, industrial, multi-family, and irrigation water services. Meter boxes with an idler will be installed by the developer. Meters will be provided by the developer for installation by the builder after building permits are issued. Meter boxes shall be set above the back of walk as required to provide for drainage away from the box and shall be adjusted, as needed, to final grade by the building contractor. Size of water meter shall not be less than the size of the service line unless approved by the County Engineer. See Standard Drawing 8-6 for specifications and typical installation details.
- D. Fire Department Connection:** A backflow prevention device shall be provided for each fire service line into a building, whether residential, commercial or industrial use. See Standard Drawing 8-7 for specifications and typical installation details. The Fire District or Department will review and approve all connection details. Contact the Fire District or Department for requirements based on specific uses, and field testing requirements. Prior to acceptance a copy of the test certification/report from an AWWA certified private Certified Backflow Prevention Assembly Tester shall be required for each device.
- E. Back-Flow Devices:** Back-flow devices are required in accordance with Title 17, Chapter V, and Sections 7583-7622 of the California Code of Regulations. See Standard Drawing 8-8 for specifications and typical installation details. Prior to acceptance a copy of the test certification/report from an AWWA certified private Certified Backflow Prevention Assembly Tester shall be required for each device.

Back-flow devices shall be provided with an insulating blanket and lockable metal enclosure, GuardShack™, or equivalent meeting the following requirements:

1. Manufactured with minimum 1¼" schedule 40 metal pipe (A.S.T.M.-A-53 Gr.A.E.W). All sharp corners on top of the enclosure shall be eliminated by using pipe formed to a 6" radius for 12" wide enclosures and a 9" radius on all 18" wide or wider enclosures.
  2. Expanded metal shall be ½" spacing, #13 gauge flattened diamond pattern steel. Expanded metal shall be "die-formed" for uniformity. There shall be no exposed ends of expanded metal on the outside of the enclosure.
  3. Welding shall be a minimum of ¼" along weld on 4" spacing.
  4. Enclosure shall be powder coated with dark green color, subject to the approval of County Engineer.
- F. Air Release/Vacuum Valve Assemblies:** Air release/vacuum valve assemblies are required at high points in a distribution system as determined by the County Engineer. See Standard Drawing 8-14 for specifications and typical installation details. Air release valve boxes shall be located at least 5 feet away from driveways, and shall be protected with bollards as required by the County Engineer.
- G. Polyethylene Wrapping:**  
All valves, fittings, DIP, copper and underground brass shall be wrapped and sealed in an 8-mil minimum thickness polyethylene encasement. Use pipe wrap tape to secure and seal to the polyethylene encasement. Damaged or scratched surfaces on epoxy coated valves and appurtenances may be repaired with an epoxy kit per manufacturer's recommendations and to the satisfaction of the County inspector prior to wrapping. Otherwise, the damaged valve shall be replaced with a new valve.
- H. Tracer wire:** A continuous number 10 AWG, insulated, single strand copper tracing wire shall be attached to all mains, service lines and appurtenances per Standard Detail 8-4 and the following:
1. Tracing wire shall be continuous between mainline valve boxes and fire hydrants. It shall be attached to the top of the pipe with 10-mil polyethylene tape every 10 feet.
  2. Tracing wires through valve boxes shall be brought to the surface by placing outside of riser, but inside the box.
  3. Tracing wire in manholes and vaults shall be attached inside the facility within nine inches of the rim.
  4. Wire splices shall be soldered and located above ground and inside of valve boxes, except for splices necessary for services.
- I. Marking tape:** A 12-inch wide, blue plastic non-detectable water pipe marking tape, marked "Buried Water Main Below," shall be placed in all main line trenches, 12 to 24 inches from the surface. Where a water main and recycled water main intersect, the plastic marking tape shall also be attached to the top of the pipe with nylon tie-wrap banded around the warning tape and the pipe every five feet on center. The warning tape shall extend to the nearest valves located on each side of said intersection.
- J. Markers:** Mains in unpaved areas shall be marked every 150 lineal feet with a blue composite utility marker having a decal stating: "Caution Water Pipeline." Appurtenances (valves, ARV's, test stations, etc.) and angle points shall also be marked. All fire hydrants shall be marked with blue, two-way, retro-reflective markers placed 6" off the street centerline on the side nearest the hydrant.
- K. Water Sampling Stations:** Water sampling stations shall be provided to the satisfaction of the County Engineer.

### **8-17 RECYCLED WATER AND NON-POTABLE WATER DISTRIBUTION MAINS**

Recycled water and non-potable water facilities may be required for use in specified areas as determined by projects conditions of approval or County policy, in consultation with the County Engineer. Design flows and demands for recycled and non-potable water systems shall be determined by the developer's engineer. Design requirements for recycled water and non-potable water distribution mains are similar to potable water; however, there are special provisions described as follows:

1. To avoid cross connection of the potable and non-potable water systems, recycled water and non-potable facilities shall be clearly marked through appropriate coloring of pipe materials and above ground appurtenances. Coloring shall be purple unless otherwise directed.
2. Pipe color shall be purple and embossed or integrally stamped/marked "CAUTION: NONPOTABLE WATER - DO NOT DRINK", or "CAUTION: RECYCLED WATER - DO NOT DRINK". Valve and meter boxes shall be colored purple and have the words "NONPOTABLE WATER" stamped into the face.
3. All above ground facilities shall be marked with signage to caution against drinking water from the recycled water system. All signs shall be made and placed in such a manner as to become a permanent part of the facility or appurtenance. Park sites, large turf areas, and other publicly used areas may require warning signs of the appropriate size as determined by the County Engineer or other regulatory agency.
4. The recycled and non-potable water system shall maintain a minimum pressure of 40 psi.
5. The recycled and non-potable water mains shall be located on the south and east side of a street (or same side as the sanitary sewer). The recycled and non-potable water mains shall be located at a minimum of four feet from the lip of gutter. The recycled and non-potable water mains and valve actuators will be located in the center of traffic lanes or on traffic lane lines. A deviation from these criteria may be allowed if approved by the County Engineer in consultation with other affected utility providers.

### **8-18 TESTING PROCEDURES**

Testing of the water system may proceed only after joint utility crossings are completed, the sewer mains and services have passed pressure test and TV inspection, the recycled water system has passed testing, and subgrade elevations have been met. Road bases to be lime-treated shall be pressure tested before and after the lime treatment process. Testing prior to subgrade placement may be subject to additional pressure tests at the discretion of the County Engineer. The new system shall be filled with potable water through an approved backflow device.

#### **A. Pressure Test:**

1. Contractor shall verify that all system valves are open prior to testing.
2. The County inspector shall be present during the duration of the test.
3. Pressure testing shall be conducted for two hours at 150 pounds per square inch or at one-and-one-half times the operating pressure, whichever is higher, as measured from the system high point. The test gauge shall be liquid-filled and capable of testing up to 300 psi.
4. No detectable leakage is allowed.

#### **B. Chlorine Disinfection:** Chlorine disinfection shall comply with the AWWA Standard for Disinfection Water Mains (C651-92) and as specified below:

1. Disinfection inspections shall begin only after passing the pressure test.
2. Prior to chlorination, pre-flush water mains and services. Preflushing is not permitted if using the Tablet Method for chlorination.

3. Chlorine shall be drawn through all mains, hydrant runs and services. The County inspector shall verify that a minimum chlorine residual of 50 parts per million (ppm) has been achieved.
4. After a 24-hour holding period, the County inspector will verify that a minimum chlorine content of 25 ppm remains in the system.
5. Upon approval by the County inspector, the water system shall be flushed to remove concentrated chlorine. Flushing shall be continued until the remaining water has a chlorine residual below 1 ppm and a turbidity equal to or less than 1 NTU. Chlorinated water shall be neutralized to 1 ppm chlorine residual or less prior to discharge. Discharge location and neutralization methods shall be documented in the SWPPP and coordinated with and approved by the County.

**C. Water Quality Testing:** Water quality samples shall be taken per the following procedure:

1. Once flushing has lowered the chlorine residual below 1 ppm and the turbidity is equal to or less than 1 NTU, the water system shall observe a minimum 24 hour detention time. Water may not be drawn during this time period.
2. After the 24-hour holding period has elapsed, water quality samples shall be collected by the County inspector for testing.
3. If the sample lot does not meet the minimum chlorine residual and turbidity criteria, additional flushing shall be required. The procedure shall be repeated until the criteria are met.
4. A minimum of 2 sets of samples at least 24 hours apart after completion of final flushing as indicated above shall be taken at locations indicated in ANSI/AWWA C651 and will be tested for coliform organisms and heterotrophic plate count. Costs for testing will be the Developer's responsibility. Satisfactory bacteriological results will be:
  - a) absence of total and fecal coliform,
  - b) a heterotrophic plate count less than 100 CFU and
  - c)  $CL_2$  Residual

**D. Continuity Testing:** The Contractor shall test continuity of the tracing wire with standard locating equipment. The County inspector shall witness all testing. Discontinuity in the tracing wire shall be repaired. It is recommended that the Contractor perform continuity testing after subgrade is made, but before asphalt is placed. Final continuity testing will take place after asphalt is placed and all valve boxes are raised.

**E. Corrosion Protection System Testing:** At the completion of the pipe installation, the corrosion engineer shall conduct a test of the corrosion monitoring system in the presence of the County inspector. A report showing the test results shall be submitted to the County for review and approval. The report shall include test station locations as called out on the approved plans, appurtenance tested, test result, and recommendations for future monitoring and maintenance.

## **8-19 RECORD PLANS**

Record Drawings shall be prepared in accordance with Section 2-11 *Record Plans* of these improvement standards and shall also include the following:

1. Each sheet of the improvement plan shall be labeled or stamped "As-Built" or "Record Drawing".
2. Elevations of the top of the end of distribution mains.
3. The type of water distribution main pipe installed shall be clearly marked on each sheet.
4. The type of end fitting and pipe at the end of the distribution mains shall be described.

5. Changes of location of shut-off valves, fittings, air release/vacuum valves, blow-off assemblies, hydrants, and water services which vary from the improvement plans.

Record Drawings shall be approved by the County Engineer prior to acceptance of the project.

<b>Standard Drawings</b>		
<b>Section 8 – Water Systems</b>		
<b>Drawing</b>	<b>Sheets</b>	<b>Description</b>
8-1	1	Water Service Installation
8-2	1	Fire Hydrant Installation Water Main in Street
8-3	1 of 2	Thrust Block Bearing Area
8-3	2 of 2	Pipe Restrained Length
8-4	1	Locating Wire for Water Mains and Services
8-5	1	Valve Box Installation and Operating Nut Extension
8-6	1 of 2	1-1/2" & 2" Metered Water Service
8-6	2 of 2	3" to 6" Meter Installation
8-7	1 of 2	Fire Sprinkler Service - Residential
8-7	2 of 2	Fire Sprinkler Service - Commercial
8-8	1 of 2	Pressure Reducing Backflow Preventer 1" to 3"
8-8	2 of 2	Pressure Reducing Backflow Preventer 4" and larger
8-9	1	Maximum Deflection for PVC Pipe
8-10	1	Utility Crossing
8-11	1	Utility Crossing under Existing Water Main
8-12	1	2" Temporary Blow Off Assembly
8-13	1	4" Blow Off Assembly at End of Main
8-14	1	Combination Air/Vacuum Valve
8-15	1	Cut-in
8-16	1	Non-Potable Recycled Water Warning Sign



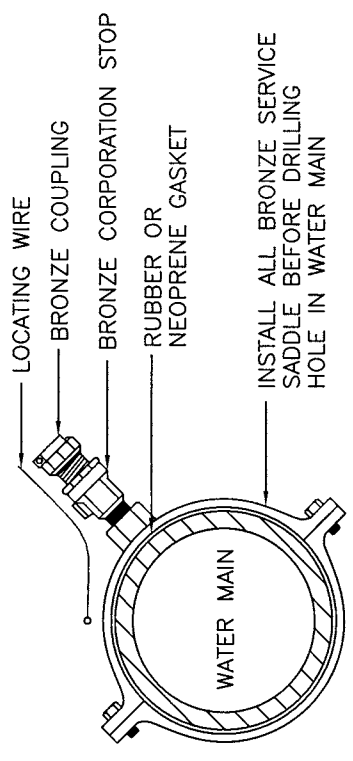
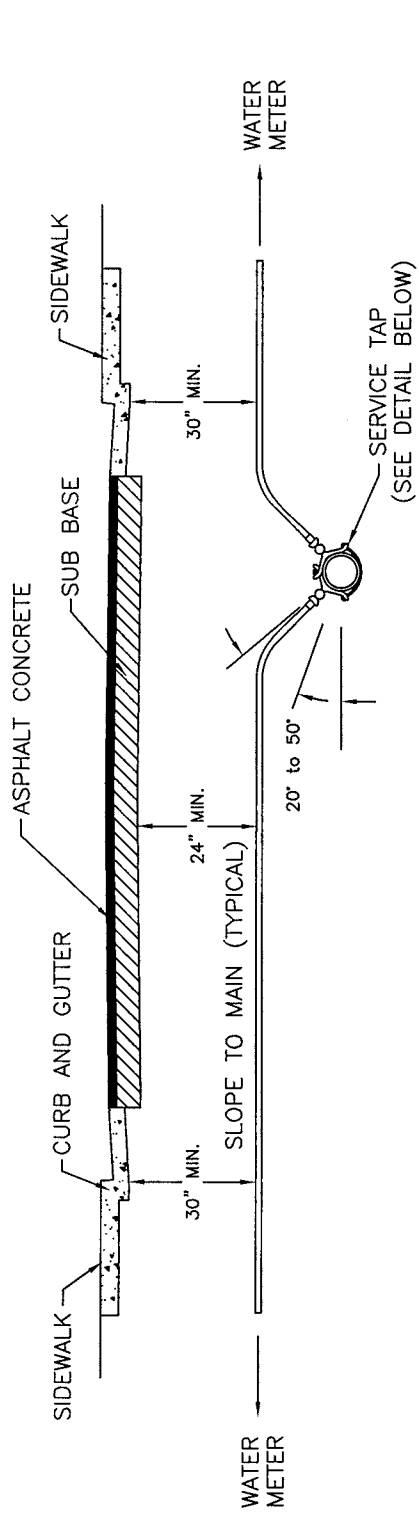

SERVICE TAP DETAIL

**NOTES:**

1. CORPORATION STOP, METER CURB STOP AND WATER SERVICE LINE ARE TO BE THE SAME SIZES.
2. SERVICE SADDLES SHALL HAVE A SINGLE WIDE BRONZE STRAP FOR 1" AND 2" SERVICES. DOUBLE STRAPS, FLATTENED TO PROVIDE A WIDE BEARING SURFACE AGAINST THE PIPE, SHALL BE USED FOR SERVICE SADDLE SIZES LARGER THAN 2 INCHES. BRONZE 'U' BOLTS (NOT FLATTENED) MAY BE PLACED ON PVC AND DUCTILE IRON WATER MAINS.
3. SERVICE SADDLES, CORPORATION STOPS, COUPLING NUTS, BOLTS, AND ALL APPURTENANCES SHALL BE BRONZE.
4. SERVICE TAP MUST BE MADE BETWEEN 20 DEGREES TO 50 DEGREES ABOVE THE SPRINGLINE OF THE PIPE.
5. SERVICE TAPS SHALL BE A MINIMUM OF 18" APART ALONG THE WATER MAIN.
6. INSULATED LOCATING WIRE REQUIRED ON ALL SERVICE LINES, SEE DRAWING 8-4. WIRE SHALL BE CONNECTED TO LOCATING WIRE ALONG WATER MAIN FOR CONTINUITY.

DATE: 08/05/08	COUNTY OF YOLO PLANNING AND PUBLIC WORKS DEPARTMENT
SHEET # 1 OF 1	WATER SERVICE INSTALLATION
DRAWING # 8-1 NOT TO SCALE	<i>Paros</i> COUNTY ENGINEER No. C42401 28 Aug-08 APPROVAL DATE

18" MIN.  
24" MAX.  
(SEE NOTE  
4 BELOW)

4" MIN.  
6" MAX.

36" MIN.

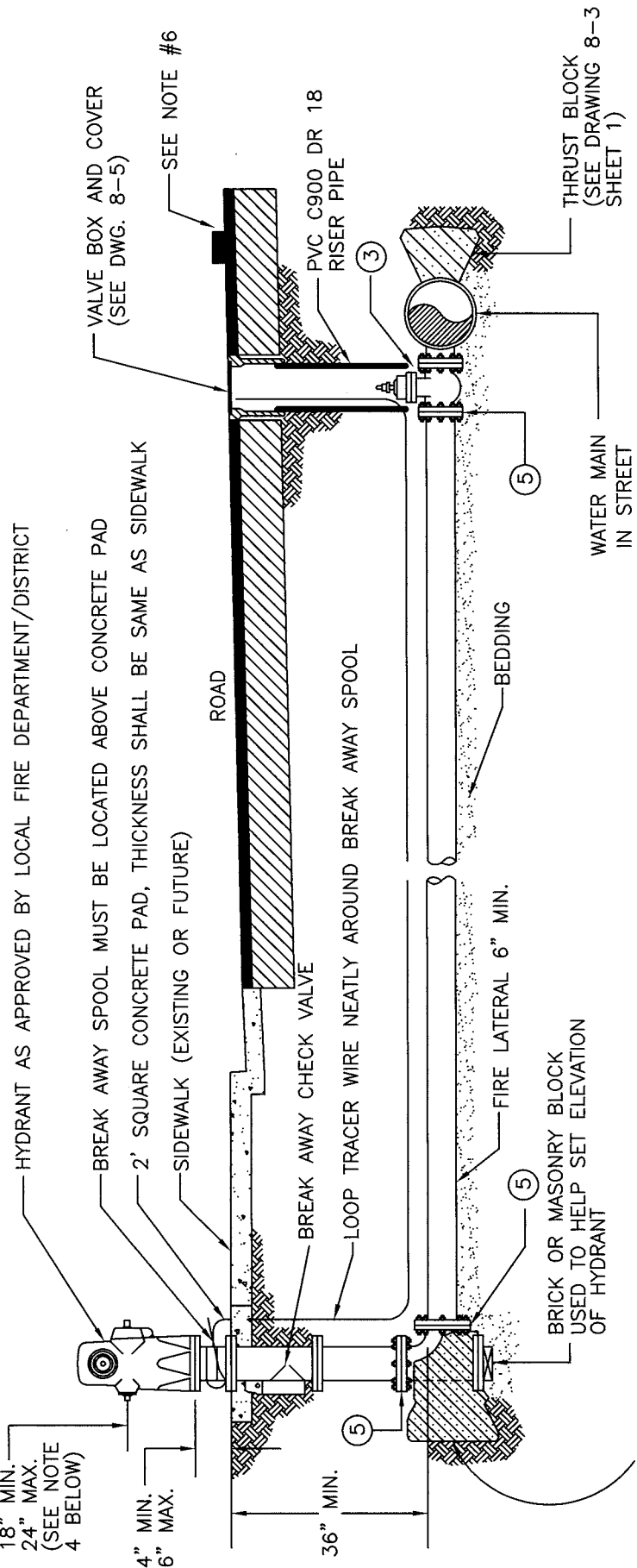

HYDRANT AS APPROVED BY LOCAL FIRE DEPARTMENT/DISTRICT

BREAK AWAY SPOOL MUST BE LOCATED ABOVE CONCRETE PAD

2' SQUARE CONCRETE PAD, THICKNESS SHALL BE SAME AS SIDEWALK

SIDEWALK (EXISTING OR FUTURE)

BREAK AWAY CHECK VALVE

LOOP TRACER WIRE NEATLY AROUND BREAK AWAY SPOOL

ROAD

VALVE BOX AND COVER (SEE DWG. 8-5)

PVC C900 DR 18 RISER PIPE

THRUST BLOCK (SEE DRAWING 8-3 SHEET 1)

WATER MAIN IN STREET

BEDDING

FIRE LATERAL 6" MIN.

BRICK OR MASONRY BLOCK USED TO HELP SET ELEVATION OF HYDRANT

CONCRETE THRUST BLOCK POURED AGAINST UNDISTURBED SOIL, TYPICAL (SEE DRAWING 8-3 SHEET 1 FOR SIZE)

**NOTES:**

1. IN COMMERCIAL AREAS, FIRE HYDRANTS SHALL BE PROTECTED FROM VEHICULAR DAMAGE BY BOLLARDS AND SHALL BE ACCESSIBLE TO FIRE PROTECTION EQUIPMENT.
2. TYPE OF FIRE HYDRANT SHOWN IS FOR ILLUSTRATION ONLY.
3. GATE VALVE SHALL BE FLANGED TO THE WATER MAIN.
4. LOWEST CAP NUT ON HYDRANT SHALL BE 18" MIN. TO 24" MAX. ABOVE TOP OF CONCRETE PAD.
5. THESE JOINTS MAY BE FLANGED, OR RESTRAINED MECHANICAL JOINTS WITH COUNTY APPROVED RESTRAINING DEVICE.
6. 2-WAY BLUE REFLECTIVE MARKER TO BE PLACED 6" FROM STREET CENTERLINE ON THE SIDE TOWARDS THE HYDRANT.
7. WRAP ALL DUCTILE IRON PIPE AND FITTINGS IN 4-MIL HDPE.
8. FOR STREETS WITH PLANTER STRIPS, HYDRANTS SHALL BE LOCATED ON THE STREET SIDE OF THE SIDEWALK.

PLANNING AND PUBLIC WORKS DEPARTMENT	DATE: 08/05/08
FIRE HYDRANT INSTALLATION WATER MAIN IN STREET	SHEET # 1 OF 1
<i>James Kalkas</i> COUNTY ENGINEER No. C42401	DRAWING #: <b>8-2</b> NOT TO SCALE
COUNTY OF YOLO APPROVAL DATE: 28 Aug. 08	

## REQUIRED BEARING AREA IN TOTAL SQUARE FEET

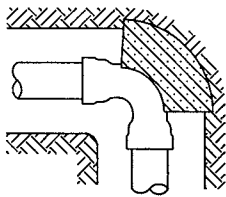
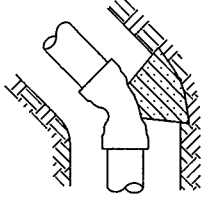
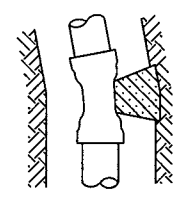
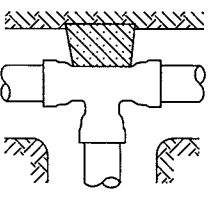

TYPE OF FITTING	90° BEND	45° BEND	11-1/4" BEND 22-1/2" BEND	TEE OR DEAD END	TEE WITH PLUG	CROSS WITH PLUG	CROSS WITH PLUGS
TYPICAL INSTALLATION							
	6"	4	2	1	3		
	8"	7	4	2	5		
	10"	12	6	3	8		
12"	16	10	5	12			
SIZE OF PIPE	THRUST BLOCKS NOT ALLOWED, SEE DRAWING 8-3 SHEET 2						

**NOTES:**

1. THRUST BLOCKS ARE TO BE CONSTRUCTED OF CLASS "B" CONCRETE.
2. BEARING AREAS GIVEN ARE FOR CLASS 150 PIPE AT TEST PRESSURE OF 150 PSI IN SOIL WITH 2,000 PSF BEARING CAPACITY. INSTALLATIONS USING DIFFERENT PIPE, TEST PRESSURES, SOIL TYPES SHOULD ADJUST AREAS ACCORDINGLY, SUBJECT TO APPROVAL.
3. THRUST BLOCKS ARE TO BE POURED AGAINST UNDISTURBED SOIL.
4. PIPE JOINTS ARE TO BE KEPT CLEAR OF CONCRETE.
5. 6" PIPE FOR HYDRANTS ONLY.

COUNTY OF YOLO PLANNING AND PUBLIC WORKS DEPARTMENT	DATE: 08/05/08
THRUST BLOCK BEARING AREA	SHEET # 1 OF 2
<i>James Kappas</i> COUNTY ENGINEER No. C42401	DRAWING #: <b>8-3</b> NOT TO SCALE
<i>28 Aug. 08</i> APPROVAL DATE	

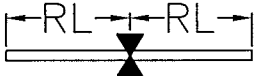
# RESTRAIN LENGTH IN FEET

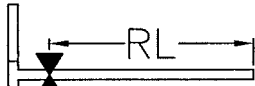
PIPE CONFIGURATION	CROSSING PIPE SIZE	DEPTH OF 36"								DEPTH OF 60"							
		6"		8"		10"		12"		6"		8"		10"		12"	
		DIP	PVC	DIP	PVC	DIP	PVC	DIP	PVC	DIP	PVC	DIP	PVC	DIP	PVC	DIP	PVC
IN LINE VALVE 		38	24	45	31	58	38	70	46	17	17	26	24	32	30	41	38
VALVE AT TEE  (SEE NOTE 3)	6	3	2	17	13	37	24	48	33	3	2	12	10	20	19	30	26
	8	2	2	12	8	27	19	43	30	2	2	6	5	17	15	27	24
	10	2	2	4	3	19	15	39	28	2	2	2	2	12	11	24	21
	12	2	2	2	2	14	10	32	24	2	2	2	2	10	8	20	19
 (SEE NOTE 4) (SEE NOTE 5)	6	2	2	18	15	41	26	50	34	2	2	14	12	22	20	32	28
	8	2	2	16	12	32	20	44	32	2	2	6	4	18	16	29	26
	10	2	2	4	4	20	17	40	32	2	2	2	2	14	12	26	24
	12	2	2	3	2	18	14	34	26	2	2	2	2	12	10	22	20

RL = RESTRAINED LENGTH

**NOTES:**

1. ALL JOINTS WITHIN THE RESTRAIN LENGTH MUST BE RESTRAINED.
2. IF RESTRAIN LENGTH IS GREATER THAN 20', DUCTILE IRON PIPE WITH THE BELL RESTRAINING DEVICES INSIDE MUST BE USED FOR THE ENTIRE RESTRAINED LENGTH.
3. RESTRAIN LENGTH FOR THE TEE DESCRIBED, ASSUMES A THRUST BLOCK IS INSTALLED AT LOCATIONS SHOWN ABOVE. IF THRUST BLOCK IS NOT INSTALLED RESTRAIN LENGTH MUST BE APPROVED BY THE COUNTY ENGINEER.
4. THIS CONFIGURATION IS ONLY TO BE USED IF A THRUST BLOCK CAN NOT BE POURED BEHIND THE TEE AND AGAINST UNDISTURBED SOIL.
5. JOINTS ON PIPES PERPENDICULAR (CROSSING PIPES) TO RESTRAIN LENGTH RUN, MUST BE RESTRAINED FOR A MIN. OF 4 FEET.
6. THE RESTRAIN LENGTHS ARE BASED ON A WATER PRESSURE OF 150 PSI. IF HIGHER PRESSURE OR HIGHER SURGE PRESSURES ARE ANTICIPATED, THEN THIS TABLE DOES NOT APPLY AND RESTRAIN LENGTH MUST BE APPROVED BY THE COUNTY ENGINEER.

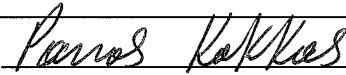
<b>COUNTY OF YOLO</b> PLANNING AND PUBLIC WORKS DEPARTMENT	DATE: 08/05/08
<b>PIPE RESTRAINED LENGTH</b>	SHEET # 2 OF 2
 COUNTY ENGINEER No. C42401	28 AUG 08 APPROVAL DATE
DRAWING #: 8-3 NOT TO SCALE	

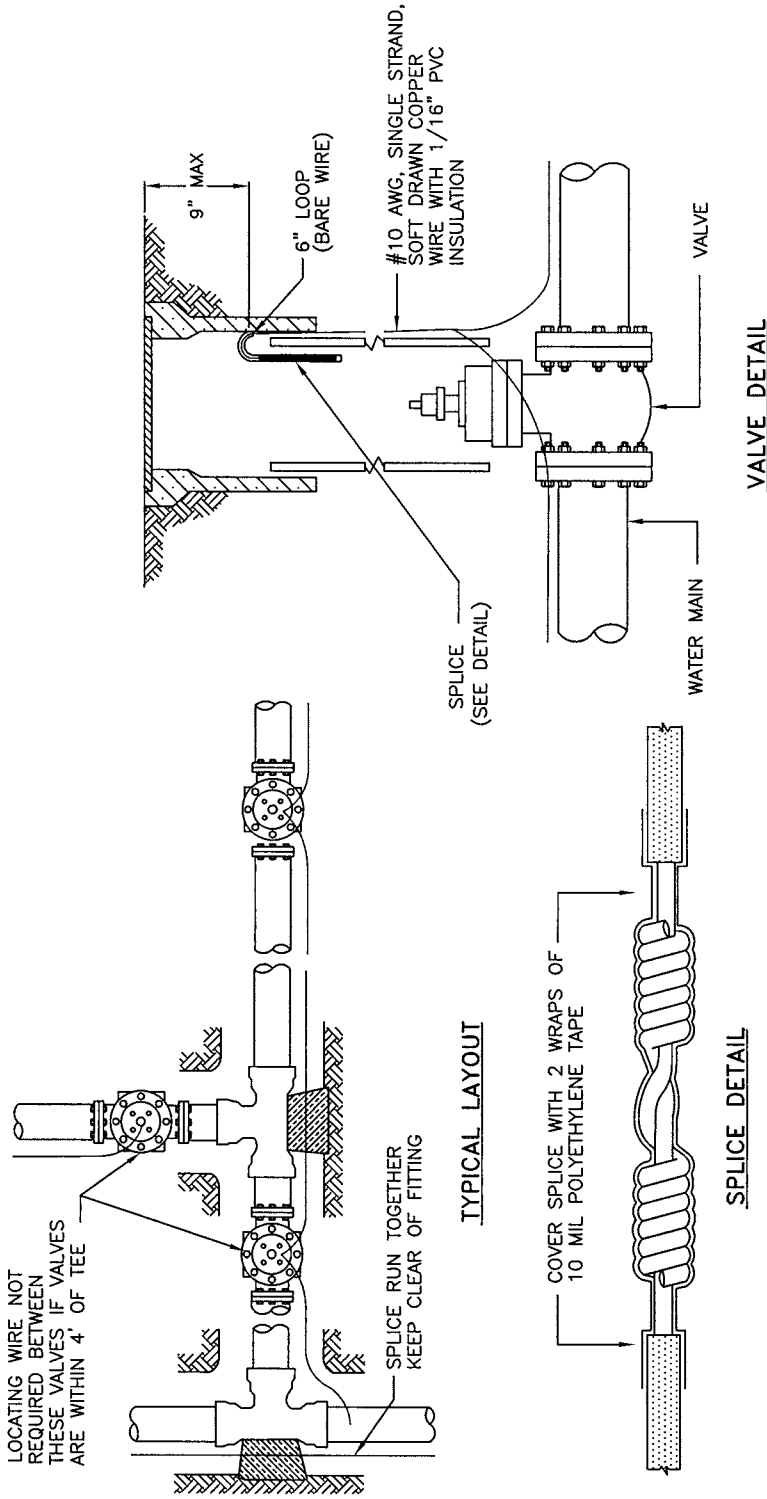

**NOTES:**

1. WIRE SHALL BE CONTINUOUS BETWEEN VALVE BOXES, EXCEPT AS NOTED.
2. LOCATING WIRE SHALL BE LAID ON TOP OF THE WATER MAIN, AND SHALL BE TAPED TO IT OR THE POLYETHYLENE ENCASEMENT (IF THE PIPE IS DUCTILE IRON) AT 10' INTERVALS AND TAPED AT ALL FITTINGS. TAPE SHALL BE 10 MIL POLYETHYLENE.
3. CONTRACTOR SHALL CONDUCT A CONTINUITY TEST ON ALL LOCATING WIRE SPLICES.
4. ALL SPLICES SHALL BE SOLDERED.
5. WRAP ALL FITTINGS AND DUCTILE IRON PIPE IN CLEAR 4-MIL HDPE.

COUNTY OF YOLO PLANNING AND PUBLIC WORKS DEPARTMENT	DATE: 08/05/08
LOCATING WIRE FOR WATER MAINS AND SERVICES	SHEET # 1 OF 1
<i>Panos Kalkas</i> COUNTY ENGINEER No. C42401	DRAWING #: 8-4 NOT TO SCALE
APPROVAL DATE 28 AUG. 08	

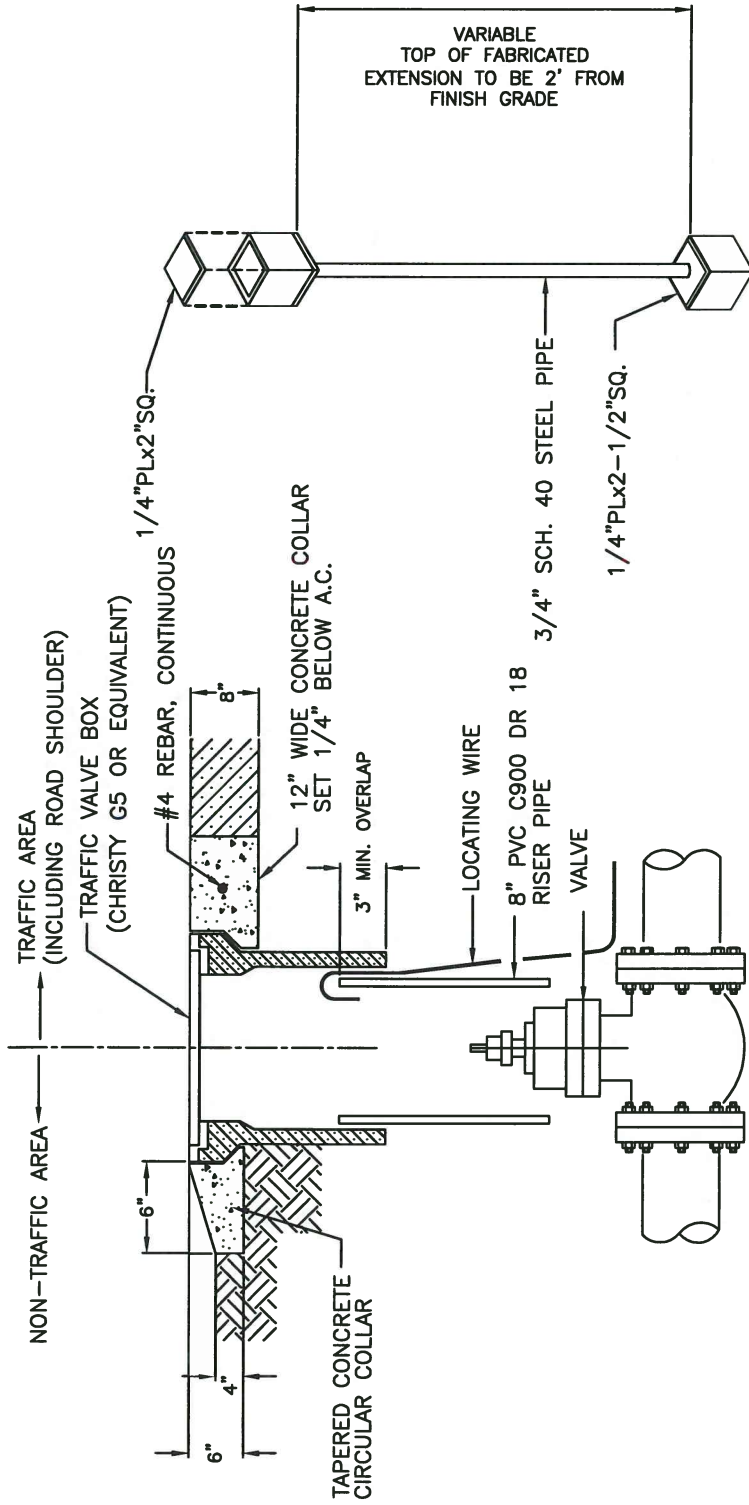

**TRAFFIC VALVE BOX**

**VALVE OPERATING NUT EXTENSION**

(REQUIRED WHERE VALVE NUT IS IN EXCESS OF 4 FEET BELOW FINISH GRADE)

**NOTES:**

1. VALVE BOX AND RISER SHALL BE TRAFFIC RATED AND SET PLUMB AND CENTERED OVER WATER VALVE NUT.
2. SET VALVE BOX TO FINAL FINISH GRADE. IN AREAS WHERE THE FINISH GRADE HAS NOT BEEN DEFINED, PLACE 4"x4" LOCATING POST PAINTED BLUE WITHIN 1 FOOT OF VALVE BOX. POST SHALL BE 6 FEET IN LENGTH AND BURIED 3 FEET.
3. WRAP ALL FITTINGS AND DUCTILE IRON PIPE IN CLEAR 4-MIL HDPE.

COUNTY OF YOLO PLANNING AND PUBLIC WORKS DEPARTMENT	DATE: 01/20/17
VALVE BOX INSTALLATION AND OPERATING NUT EXTENSION	SHEET # 1 OF 1
<i>Paros Kerkay</i> 20 JAN. 2017 COUNTY ENGINEER No. C42401	DRAWING #: 8-5 NOT TO SCALE
APPROVAL DATE	

PUBLIC PRIVATE

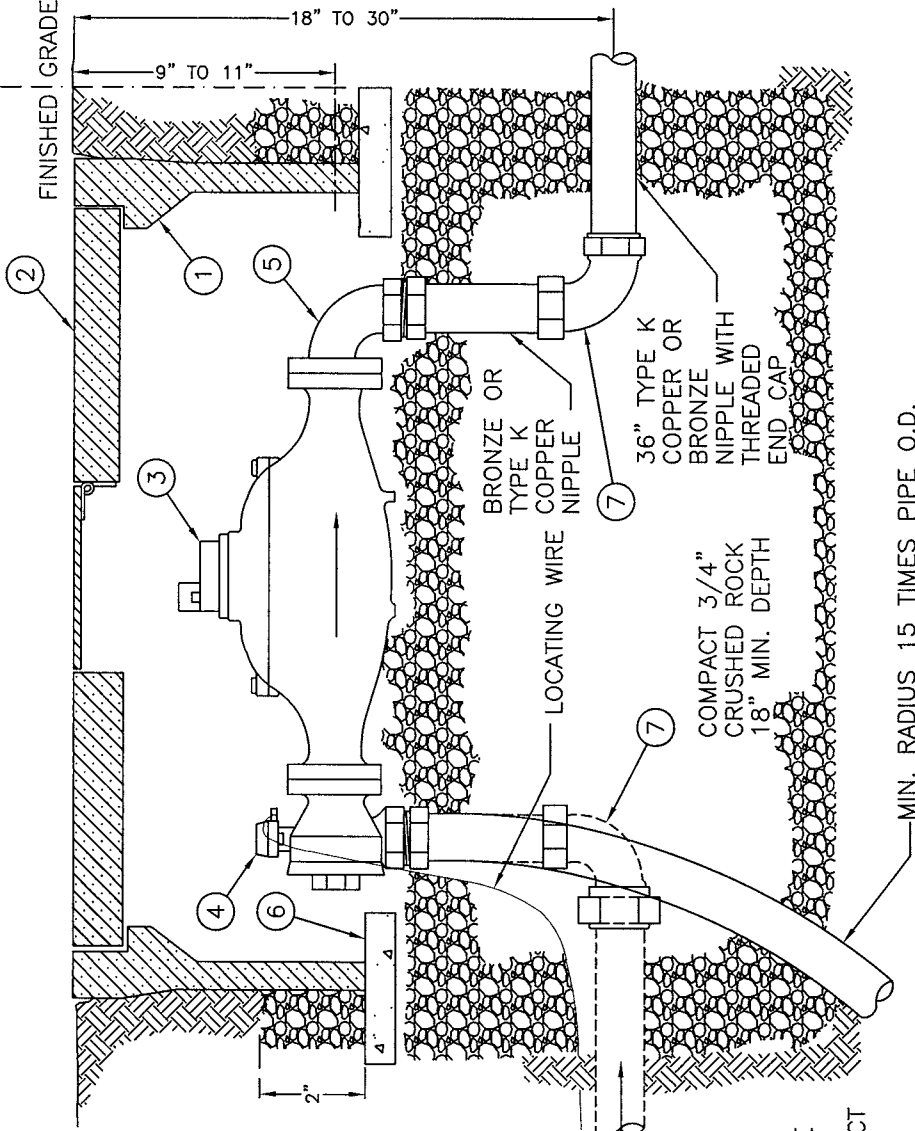

**NOTES:**

- ① REINFORCED CONCRETE UTILITY BOX. (CHRISTY B36 BOX, OR EQUIVALENT)
- ② REINFORCED CONCRETE COVER WITH A HINGED CAST IRON LID AND WATER LABEL. (CHRISTY B36G COVER OR EQUIVALENT)
- ③ AMCO C700 WATER METER WITH "INSIDER" TRANSMITTER OR COUNTY APPROVED EQUIVALENT.
- ④ FLANGED WINGED ANGLE METER STOP WITH TEFLON COATED BALL.
- ⑤ OVAL FLANGED 90° BRONZE FITTING.
- ⑥ 1"x4"x16" CONCRETE BLOCK TO HELP SUPPORT VALVE BOX, USE ONE BLOCK ON ALL FOUR SIDES OF METER BOX. COVER ANY OPENINGS OR HOLES IN THE SIDE OF THE UTILITY BOX WITH CONCRETE BLOCK.
- ⑦ BRONZE COMPRESSION BY THREADED 90° FITTING.
- ⑧ ALL METAL PIPES AND FITTING THAT ARE BURIED SHALL BE ENCASED WITH 6 MIL PLASTIC SO THAT NO SOIL IS IN CONTACT WITH THE PIPES AND FITTINGS.
- ⑨ METER BOXES SHALL NOT BE INSTALLED IN SIDE YARD SWALES OR AREAS SUBJECT TO PONDING.
- ⑩ MARK ALL METER BOXES WITH A 2" HIGH "W" WET STAMPED ON FACE OF CURB.

COUNTY OF YOLO PLANNING AND PUBLIC WORKS DEPARTMENT	DATE: 08/05/08
1-1/2" OR 2" METERED WATER SERVICE	SHEET # 1 OF 2
<i>Paros</i> COUNTY ENGINEER No. C42401	DRAWING #: 8-6 NOT TO SCALE
APPROVAL DATE 28 AUG-08	

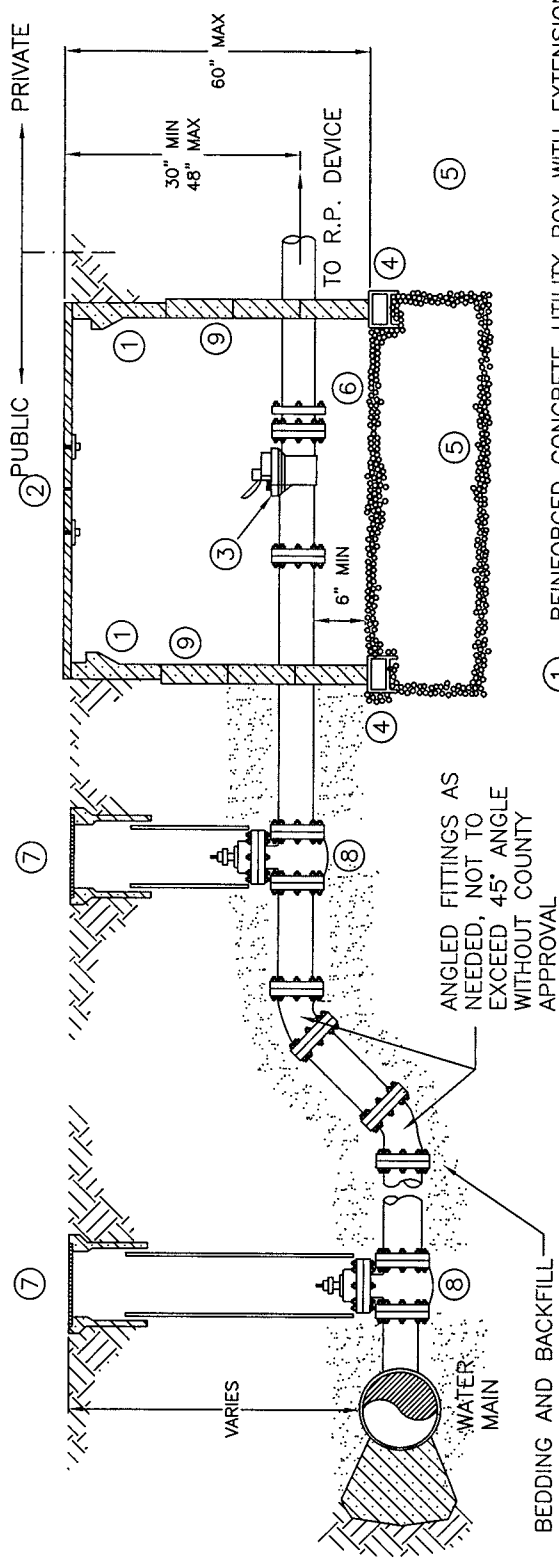

**NOTES:**

1. WHEN NEEDED CONCRETE BLOCKS SHALL BE USED TO BLOCK ANY OPENING OR CUT OUT PORTIONS OF THE METER BOX NOT UTILIZED. (MINIMUM OF 1" THICK BLOCK ARE REQUIRED)
2. ALL 4" TO 6" DIA. PIPE BETWEEN THE WATER MAIN AND THE METER SHALL BE DUCTILE IRON WITH POLYETHYLENE ENCASUREMENT AND 6--INCHES OF SAND BACKFILL AND 6--INCHES OF SAND BEDDING. JOINTS BETWEEN MAIN AND METER SHALL BE RESTRAINED.
3. 3" PIPE SHALL BE TYPE K COPPER OR BRONZE WRAPPED WITH 6 MIL PLASTIC AND HAVE SAND BEDDING AND BACKFILL. VALVES ON 3 INCH DIAMETER PIPE SHALL HAVE BRONZE CORPORATION AND CURB VALVES WITH TEFLON COATED BALLS.
4. VALVES ATTACHED TO THE MAIN MUST HAVE FLANGED ENDS.
5. INSTALL LOCATING WIRE PER 8-4.
6. METER BOXES SHALL NOT BE INSTALLED IN SIDYARD SWALES OR AREAS SUBJECT TO PONDING. METER BOXES SHALL BE INSTALLED BEHIND SIDEWALK.
7. WRAP ALL FITTINGS AND DUCTILE IRON PIPE IN CLEAR 4-MIL HDPE.

- ① REINFORCED CONCRETE UTILITY BOX WITH EXTENSIONS. (CHRISTY B4B)
- ② PIECE STEEL CHECKER PLATE WITH TWO 10" ROUND SELF-CLOSING READING LIDS. (CHRISTY B48-62G COVER, OR EQUIVALENT.)
- ③ ELSTER AMCO TS4000 WATER METER OR COUNTY APPROVED EQUIVALENT, WITH AUTOMATIC METER READING CAPABILITY. CONCRETE BLOCKS SHALL BE PLACED UNDER THE ENTIRE PERIMETER TO SUPPORT BOX.
- ④ 3/4" CRUSHED ROCK SUB-BASE, 12" TO 18" DEEP, COMPACT TO 90% RELATIVE COMPACTION.
- ⑤ FLANGED COUPLING ADAPTER.
- ⑥ VALVE BOX AND LID. (SEE 8-5)
- ⑦ GATE VALVE, WITH BOTH ENDS FLANGED.
- ⑧ METER BOX EXTENSION. (TYPICAL)

COUNTY OF YOLO PLANNING AND PUBLIC WORKS DEPARTMENT	DATE: 08/05/08
3" TO 6" METER INSTALLATION	SHEET # 2 OF 2
<i>Parnes Kollas</i> COUNTY ENGINEER No. C42401	DRAWING #: 8-6 NOT TO SCALE
APPROVAL DATE <i>28 Aug 08</i>	



COUNTY MAINTENANCE RESPONSIBILITY | HOMEOWNER MAINTENANCE RESPONSIBILITY

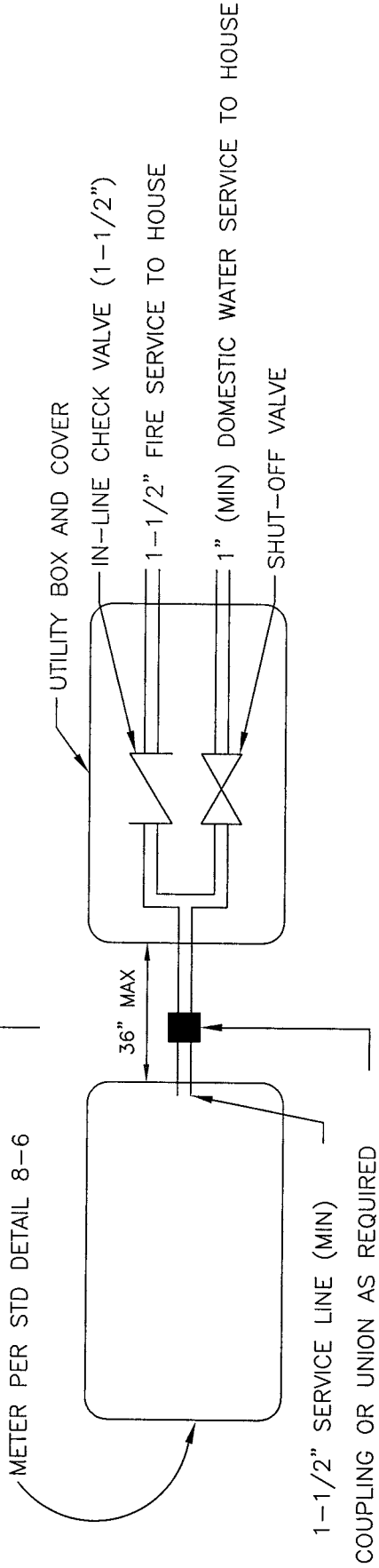

**NOTES:**

1. THE RESIDENTIAL SERVICE DETAILS ARE APPLICABLE ON SINGLE-FAMILY RESIDENTIAL SERVICES ONLY. ALL OTHERS SHALL USE THE COMMERCIAL STANDARDS.
2. FIRE SERVICE IMPROVEMENTS SHALL BE INSTALLED CONCURRENTLY WITH HOUSE CONSTRUCTION.
3. ALL IMPROVEMENTS SUBJECT TO COUNTY BUILDING PERMIT AND FIRE DISTRICT INSPECTION AND APPROVAL.
4. ALL CONNECTIONS SHALL BE THREADED OR GLUE JOINT ONLY.

COUNTY OF YOLO PLANNING AND PUBLIC WORKS DEPARTMENT	DATE: 08/05/08
FIRE SPRINKLER SERVICE - RESIDENTIAL	SHEET # 1 OF 2
<i>Pavlos Kalkas</i> COUNTY ENGINEER No. C42401	DRAWING #: 8-7 NOT TO SCALE
APPROVAL DATE 28 AUG 08	

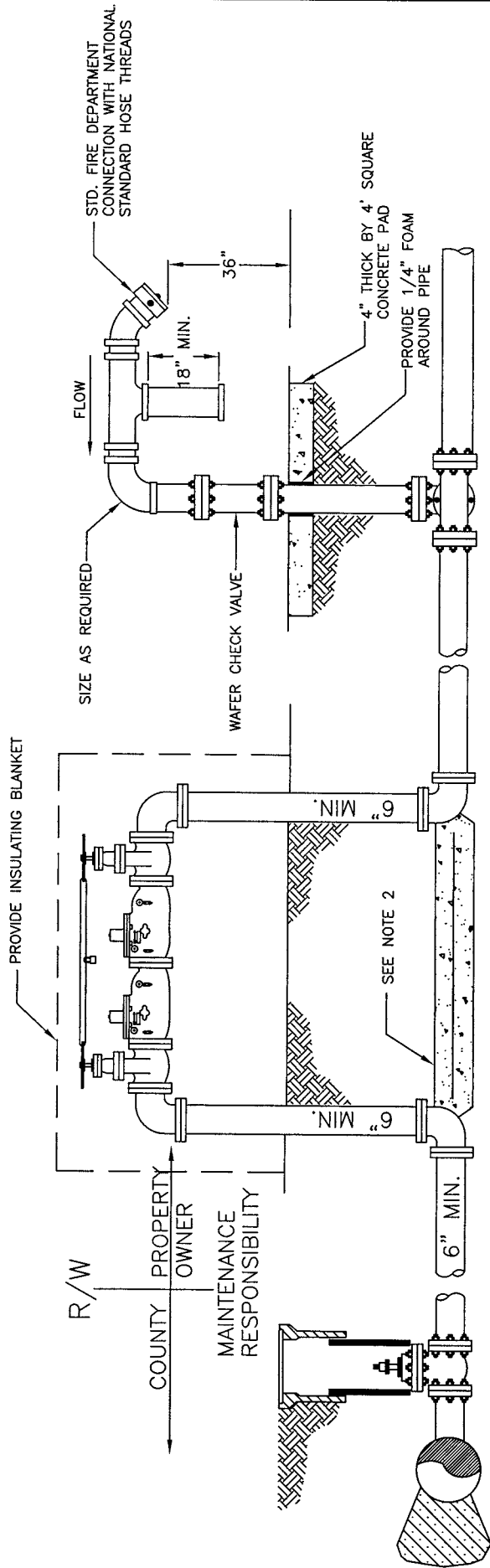

**NOTES:**

1. ALL JOINTS TO BE FULLY RESTRAINED. ALL PIPE & FITTINGS SHALL BE DUCTILE IRON.
2. CONCRETE THRUST BLOCK WITH ONE PIECE OF #4 REBAR.
3. DOUBLE DETECTOR CHECK VALVE ASSEMBLY (AMES OR APPROVED EQUIVALENT), REDUCED PRESSURE TYPE, WITH OS&Y RESILIENT WEDGE GATE VALVES, REFER TO CURRENT LIST OF APPROVED BACKFLOW PREVENTION ASSEMBLIES PUBLISHED BY THE STATE OF CALIFORNIA DEPARTMENT OF HEALTH SERVICES. OS&Y VALVES TO BE LOCKED WITH FIRE DEPARTMENT APPROVED PADLOCK AND FITTED WITH TAMPER SWITCHES AS REQUIRED ON FIRE SYSTEM APPLICATION.
4. CHECK VALVE AND PIPE SHALL BE U.L.-F.M. APPROVED. REFER TO SECTION 8-16 FOR TESTING AND CERTIFICATION REPORT REQUIREMENTS.
5. INSTALLATION MAY VARY WITH FIELD CONDITIONS AND FIRE DEPARTMENT REQUIREMENTS.
6. WRAP BURIED DUCTILE IRON PIPE AND FITTINGS IN CLEAR 4-MIL HDPE.

<b>COUNTY OF YOLO</b> PLANNING AND PUBLIC WORKS DEPARTMENT	DATE: 08/05/08
FIRE SPRINKLER SERVICE - COMMERCIAL	SHEET # 2 OF 2
<i>Parnes Hopkins</i> COUNTY ENGINEER No. C42401	DRAWING #: 8-7 NOT TO SCALE
APPROVAL DATE 28 Aug. 08	

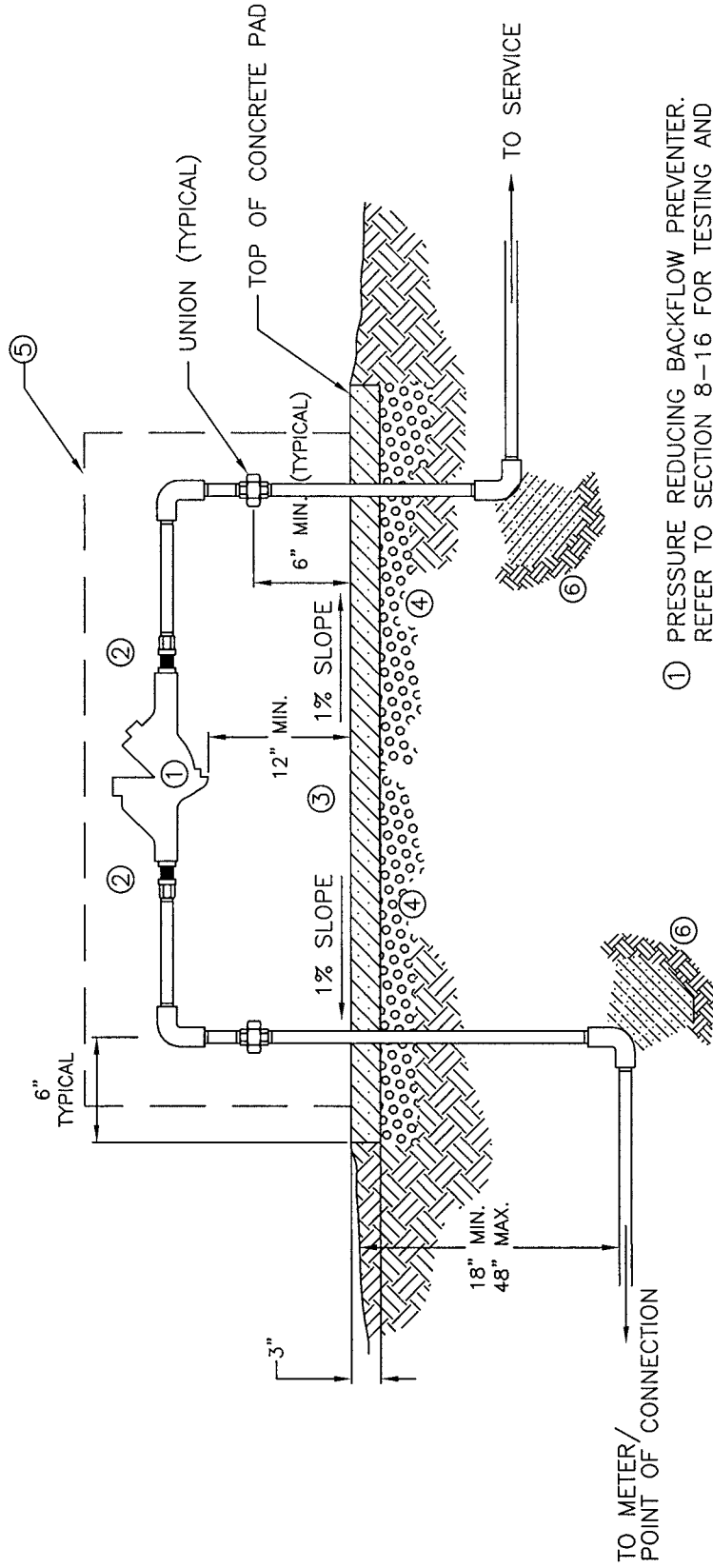

- ① PRESSURE REDUCING BACKFLOW PREVENTER. REFER TO SECTION 8-16 FOR TESTING AND CERTIFICATION REQUIREMENTS.
- ② BRONZE BODY, RESILIENT SEATED BALL VALVE MINIMUM WORKING PRESSURE OF 175 PSI.
- ③ 3" SLAB - 24" WIDE WITH VARYING LENGTH.
- ④ 1/2" OR 3/4" CRUSHED ROCK, 4" MINIMUM THICKNESS, MECHANICALLY COMPACTED TO 95% COMPACTION.
- ⑤ PROVIDE LOCKABLE PROTECTIVE ENCLOSURE AND INSULATED BLANKET FOR PRESSURE REDUCING BACKFLOW ASSEMBLY. REFER TO SECTION 8-16.
- ⑥ THRUST BLOCK

**NOTES:**

1. PRESSURE REDUCING BACKFLOW PREVENTER VALVES SHALL BE LISTED ON THE STATE OF CALIFORNIA'S DEPARTMENT OF HEALTH SERVICES MOST RECENT LIST OF APPROVED REDUCED PRESSURE BACKFLOW PREVENTERS.
2. ALL PIPES SHALL BE GALVANIZED SCHEDULE 40 STEEL, TYPE K COPPER, OR BRONZE. ALL BURIED PIPES SHALL BE WRAPPED WITH 6 MIL. POLYETHYLENE ENCASUREMENT OR 10 MIL POLYETHYLENE TAPE.
3. GALVANIZED PIPE SHALL HAVE ANODE BAG PER COUNTY BUILDING INSPECTION REQUIREMENTS CODE.

COUNTY OF YOLO PLANNING AND PUBLIC WORKS DEPARTMENT	DATE: 08/05/08
PRESSURE REDUCING BACKFLOW PREVENTER 1" TO 3"	SHEET # 1 OF 2
<i>Panos</i> COUNTY ENGINEER No. C42401	DRAWING #: 8-8
<i>20Aug08</i> APPROVAL DATE	NOT TO SCALE

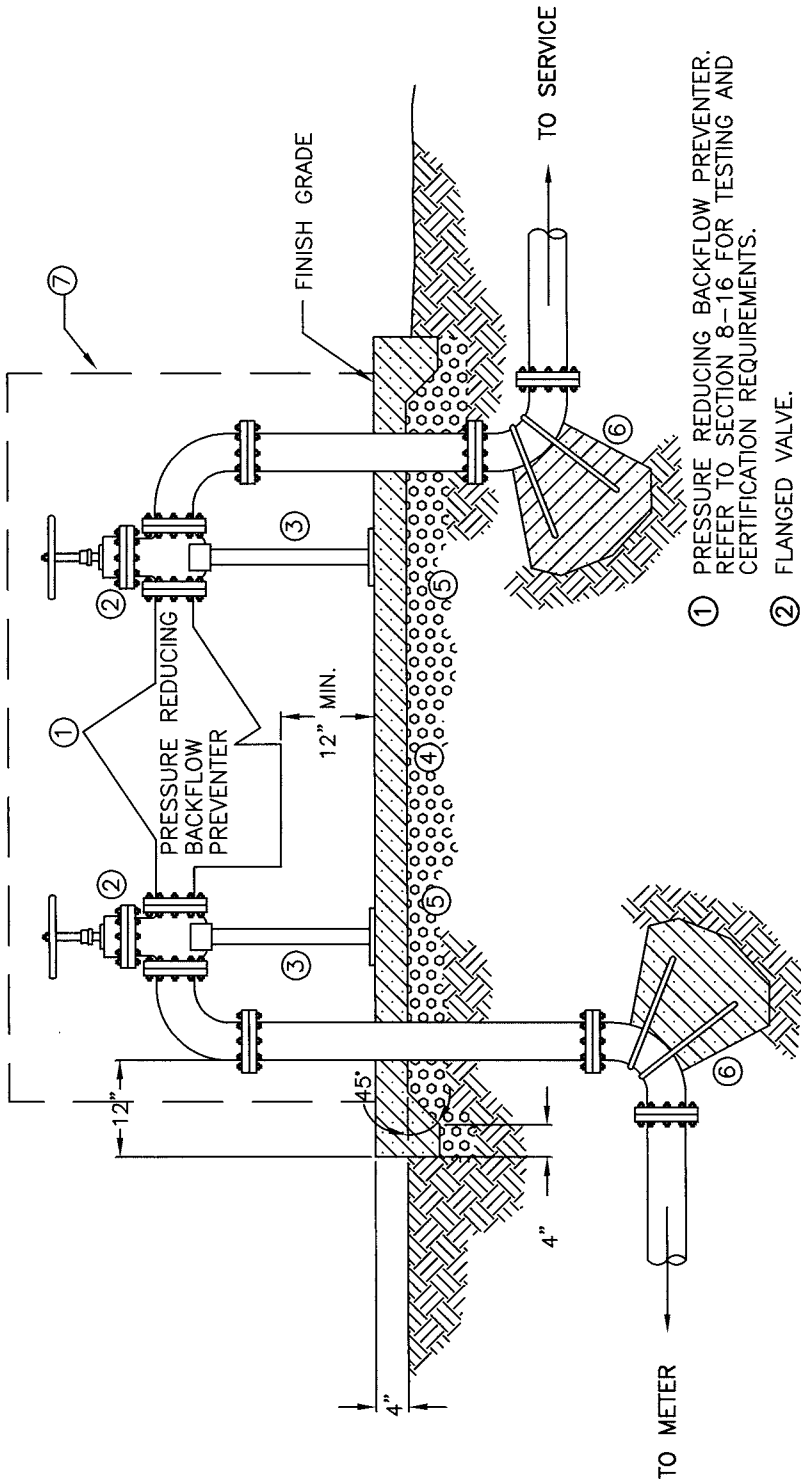

**NOTES:**

1. PRESSURE REDUCING BACKFLOW PREVENTER VALVES SHALL BE LISTED ON THE STATE OF CALIFORNIA'S DEPARTMENT OF HEALTH SERVICES MOST RECENT LIST OF APPROVED REDUCED PRESSURE BACKFLOW PREVENTERS.
2. INSTALL LOCATING WIRE PER DRAWING 8-4.
3. ALL PIPE SHALL BE CEMENT LINED DUCTILE IRON, CLASS 350 MEETING THE REQUIREMENTS OF AWWA C151 AND C115 ALL JOINTS SHALL BE FLANGED. FLANGES SHALL CONFORM TO AWWA C207, CLASS D REQUIREMENTS.
4. BURIED PIPE SHALL BE WRAPPED WITH 8 MILS OF POLYETHYLENE ENCASEMENT WITH SAND BEDDING AND BACKFILL.

- ① PRESSURE REDUCING BACKFLOW PREVENTER. REFER TO SECTION 8-16 FOR TESTING AND CERTIFICATION REQUIREMENTS.
- ② FLANGED VALVE.
- ③ PIPE SUPPORT, 2" GALVANIZED SCHEDULE 40 MINIMUM.
- ④ 4" CONCRETE SLAB - 24" WIDE WITH VARYING LENGTH.
- ⑤ 6" OF CRUSHED AGGREGATE COMPACTED TO 95% COMPACTION.
- ⑥ THRUST BLOCK WITH #5 REBARS. WRAP THE PORTION OF THE REBAR THAT IS NOT EMBEDDED IN THE CONCRETE WITH 20 MIL POLYETHYLENE TAPE. SEE DRAWING 8-3 FOR SIZING.
- ⑦ PROVIDE LOCKABLE PROTECTIVE ENCLOSURE AND INSULATED BLANKET FOR PRESSURE REDUCING BACKFLOW ASSEMBLY.

<b>COUNTY OF YOLO</b>	DATE: 08/05/08
PLANNING AND PUBLIC WORKS DEPARTMENT	SHEET # 2 OF 2
PRESSURE REDUCING-BACKFLOW PREVENTER 4" AND LARGER	DRAWING #: 8-8 NOT TO SCALE
<i>Ramos Koplos</i> COUNTY ENGINEER No. C42401	APPROVAL DATE 28 AUG 08

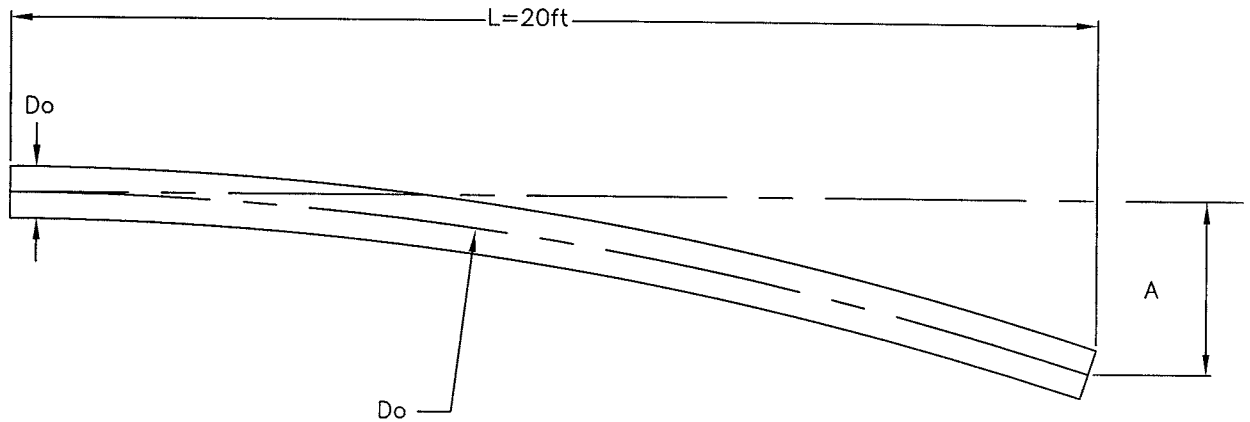

$D_o$  = AVERAGE OUTSIDE PIPE DIAMETER (INCHES)  
 $A$  = OFFSET AT THE END OF PIPE (INCHES)  
 $R_b$  = MINIMUM BENDING RADIUS (FEET)

MAX. DEFLECTION FOR PVC PIPE, AWWA C900 CLASS 200			
Normal Pipe Diameter	Average Outside Pipe Diameter, $D_o$	Minimum Wall Thickness	Minimum Bending Radius, $R_b$
(inches)	(inches)	(inches)	(feet)
6	6.900	0.493	204
8	9.050	0.646	266
10	11.100	0.793	329
12	13.200	0.943	385

**NOTE:**

1. JOINT DEFLECTION OF AWWA C900 PVC PIPE IS PROHIBITED.

COUNTY OF YOLO PLANNING AND PUBLIC WORKS DEPARTMENT		DATE: 08/05/08
MAXIMUM DEFLECTION FOR PVC PIPE		SHEET # 1 OF 1
<i>Panos Kakkas</i> COUNTY ENGINEER No. C42401	28 AUG. 08 APPROVAL DATE	DRAWING #: 8-9 NOT TO SCALE

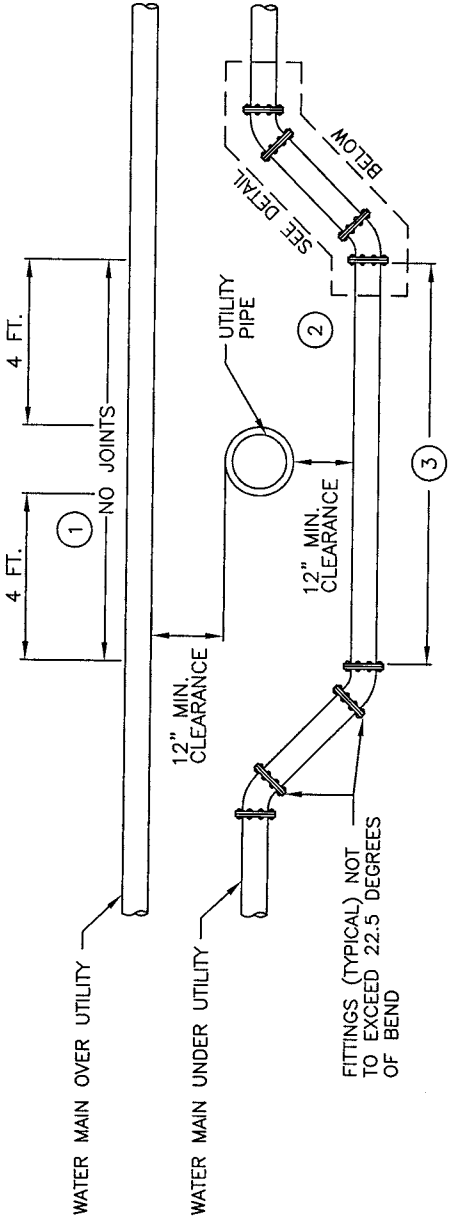

- ① IF UTILITY BEING CROSSED IS NOT A STORM DRAIN, SEWER, OR OTHER WATER LINE, THEN THE "NO JOINT" REQUIREMENT DOES NOT APPLY.
- ② IF THE UTILITY BEING CROSSED IS A SEWER, STORM DRAIN OR OTHER WATER LINE, THE TYPE OF PIPE MUST BE DUCTILE IRON OR AWWA C900 DR 14 PVC PIPE.
- ③ NO JOINTS ALLOWED IF LESS THAN 18 FEET. ALL JOINTS BETWEEN FITTINGS MUST BE RESTRAINED WITH EITHER OF THE METHODS DESCRIBED FOR DIP. BELL RESTRAINTS FOR PVC PIPE ARE NOT ALLOWED.

**LEGEND**

DIP=DUCTILE IRON PIPE  
 AWWA=AMERICAN WATER WORKS ASSOCIATION  
 PVC=POLYVINYL CHLORIDE PIPE  
 POJ=PUSH ON JOINTS

FITTINGS (TYPICAL) NOT TO EXCEED 22.5 DEGREES OF BEND

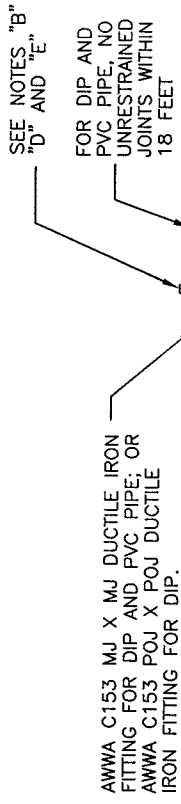

**NOTES:**

- A. IF DIP IS USED, FITTINGS MAY HAVE BELL ENDS WITH U.S. PIPE FIELD LOK GASKETS FOR RESTRAINING DEVICES OR APPROVED EQUIVALENT. BELL RESTRAINTS FOR PVC PIPE ARE NOT ALLOWED.
- B. IF BEND IS TO EXCEED 22.5 DEGREES, THE BEND AND THE RESTRAIN LENGTH MUST BE APPROVED BY THE COUNTY.
- C. WRAP ALL DIP AND FITTINGS WITH 8 MIL. POLYETHYLENE ENCASEMENT IN ACCORDANCE WITH AWWA C105.
- D. RESTRAINING DEVICE FOR DIP: FOR POJ's USE U.S. PIPE FIELD LOK GASKETS OR APPROVED EQUIVALENT, FOR MJ JOINTS USE STAR PIPE PRODUCTS STARGRIP 3000, STAR PIPE PRODUCTS ALLGRIP 3600, EBAA MEGALUG 2000PV SERIES, OR APPROVED EQUIVALENT.
- E. RESTRAINING DEVICE FOR PVC PIPE: USE MJ FITTINGS WITH STAR PIPE PRODUCTS ALLGRIP 3600, EBAA MEGALUG 2000PV SERIES, OR APPROVED EQUIVALENT.
- F. SEE PLAN AND PROFILE FOR RESTRAINED LENGTH AND DEGREE OF BEND.
- G. THIS DETAIL IS FOR WATER PIPES 12" IN DIAMETER AND SMALLER.

<b>COUNTY OF YOLO</b>		DATE: 08/05/08
PLANNING AND PUBLIC WORKS DEPARTMENT		SHEET # 1 OF 1
UTILITY CROSSING		DRAWING #: 8-10
<i>Panos Kollas</i> COUNTY ENGINEER No. C42401		APPROVAL DATE: 28 AUG 08
		NOT TO SCALE

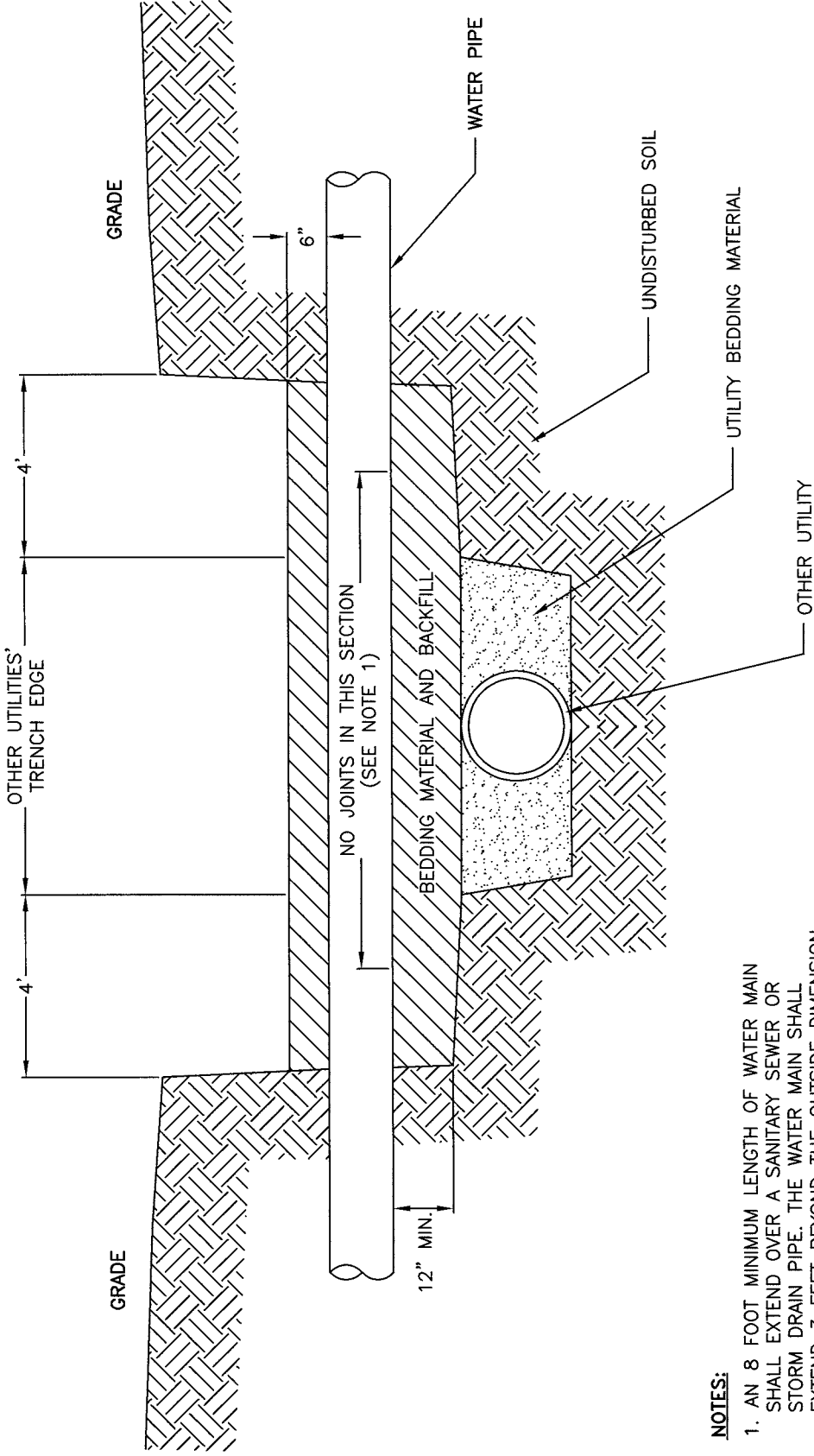

**NOTES:**

1. AN 8 FOOT MINIMUM LENGTH OF WATER MAIN SHALL EXTEND OVER A SANITARY SEWER OR STORM DRAIN PIPE. THE WATER MAIN SHALL EXTEND 3 FEET BEYOND THE OUTSIDE DIMENSION OF ALL OTHER UTILITIES, OR AS REQUIRED BY THE CALIFORNIA DEPARTMENT OF HEALTH.
2. USE 1/2" CRUSHED AGGREGATE FOR PVC WATER PIPE. USE SAND FOR DUCTILE IRON WATER PIPE. COMPACT BEDDING AND BACKFILL MATERIAL TO 90% RELATIVE COMPACTION.

DATE: 08/05/08	COUNTY OF YOLO PLANNING AND PUBLIC WORKS DEPARTMENT
SHEET # 1 OF 1	UTILITY CROSSING UNDER EXISTING WATER MAIN
DRAWING #: 8-11 NOT TO SCALE	<i>Panos Kokkas</i> COUNTY ENGINEER No. C42401 28 AUG. 08 APPROVAL DATE

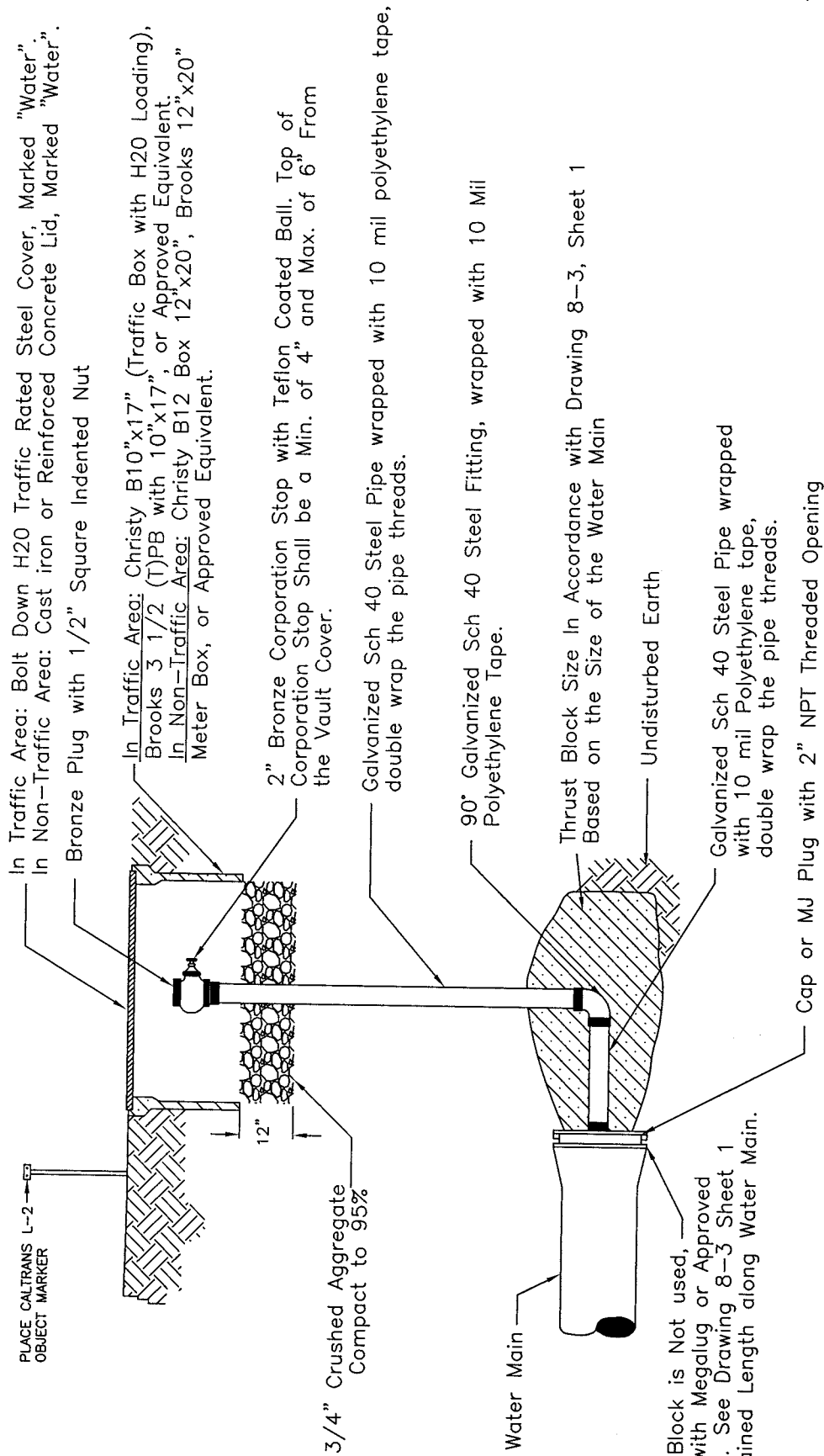

**NOTE:**

Backfill with Native Material and Compact to 90% Compaction. In traffic areas the backfill and compaction requirements for the road shall govern.

PLANNING AND PUBLIC WORKS DEPARTMENT	COUNTY OF YOLO	DATE: 08/05/08
2" TEMPORARY BLOW OFF ASSEMBLY		SHEET # 1 OF 1
<i>James Kelkas</i> COUNTY ENGINEER No. C42401	28 AUG. 08 APPROVAL DATE	DRAWING #: 8-12 NOT TO SCALE



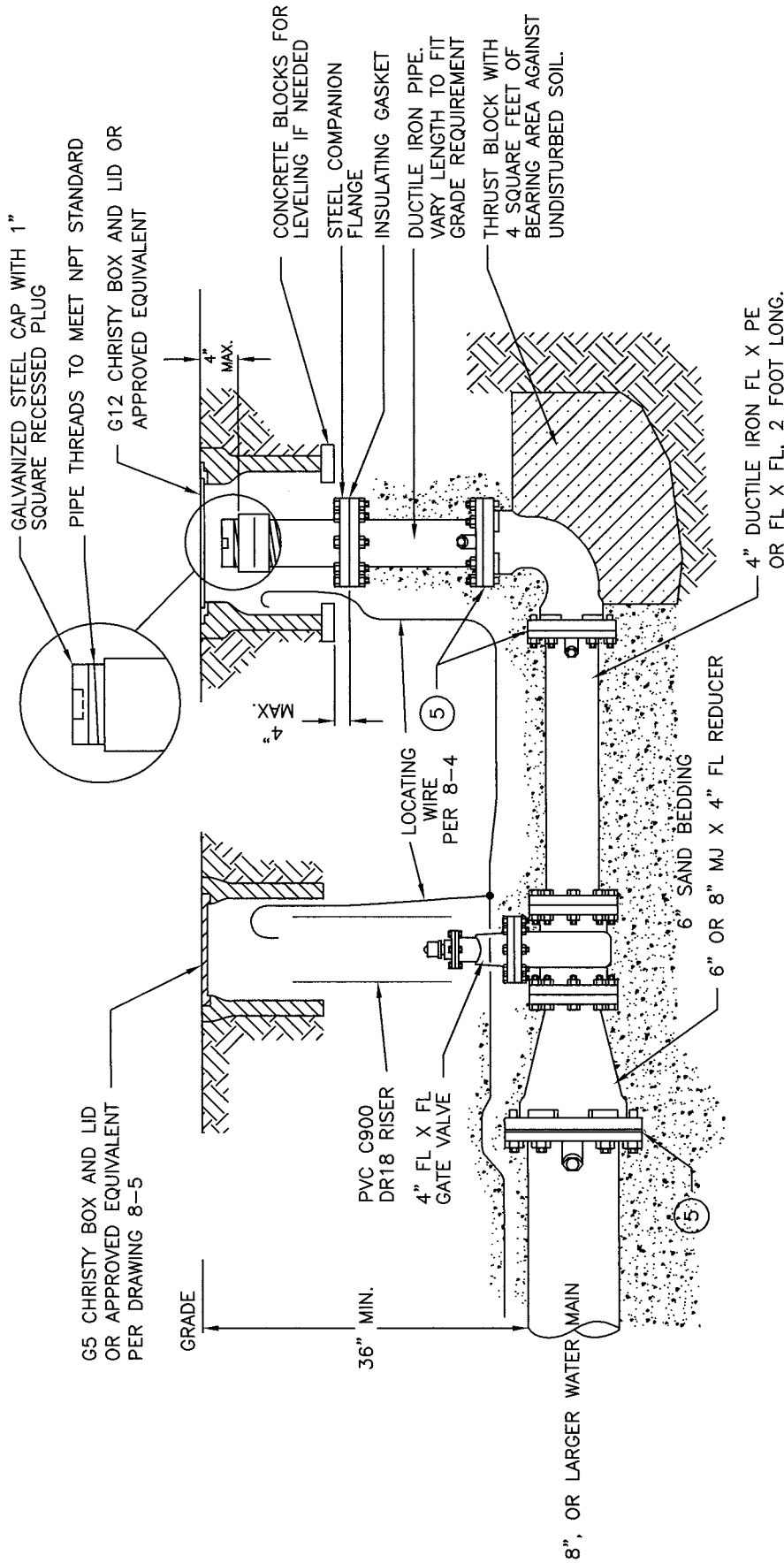

**NOTES:**

1. WRAP 4" GATE VALVE AND ALL METAL FITTINGS AND PIPE WITH 8 MIL POLYETHYLENE ENCASEMENT PER AWWA C105.
2. ALL FITTINGS SHALL HAVE A MINIMUM PRESSURE CLASS OF 200 PSI AND MEET AWWA C110 OR AWWA C153 STANDARDS.
3. PROVIDE 6 INCHES OF SAND BEDDING AND BACKFILL WITH SAND TO 6 INCHES ABOVE THE TOP OF PIPE AND FITTINGS. COMPACT TO 90% RELATIVE COMPACTION.
4. GALVANIZED STEEL PIPE NOT ALLOWED.
5. THESE JOINTS MUST BE RESTRAINED. TYPES OF RESTRAINED JOINTS MAY BE: (1) FLANGE, (2) MJ WITH APPROVED RESTRAINING DEVICES (EBAA OR STAR PIPE PRODUCTS). OR (3) FOR D.I.P., PUSH ON JOINTS WITH U.S. PIPE FIELD-LOK GASKET OR APPROVED EQUIVALENT.

COUNTY OF YOLO  
PLANNING AND PUBLIC WORKS DEPARTMENT

DATE: 08/05/08

4" BLOW OFF ASSEMBLY  
AT END OF MAIN

SHEET #  
1 OF 1

*Parras*  
COUNTY ENGINEER No. C42401

DRAWING #:  
8-13  
NOT TO SCALE

APPROVAL DATE  
28 AUG 08

3/16" steel, 6" x 6" rectangular tube 18" high with an 8-1/2" cap, spot welded at the top. Clean interior and exterior of steel with a water based cleaner. Devprep 88 or equivalent. Factory apply 1 coat, at 2.0 mils, of Inmec series 135 epoxy primer, then 1 coat, at 2.0 mils of Inmec series 28 acrylic to the cap, tube, and top of the lid of the utility box. Color to be Hunter Green or approved equivalent.

2-3/8" Bolts, Grade 3 with washer

1/4" thick steel lid. Tack Weld 1/4" thick by 1" wide steel plate around perimeter of lid so top of lid is flush with top of box. Cut 5"x5" square hole in top of lid. Square hole to be centered relative to width of lid. Lid and tube assembly shall be PWAE118M or approved equivalent. Lid shall be bolted to box.

Weld 2 locking nuts to lid to accept bolts.

1" schedule 40 Galvanized steel pipe with steel threaded coupling and 1" to 3/4" PVC adapter. Operator must be able to unscrew PVC Riser from coupling.

1" Crispin UL-10 Combination Air Release/ Vacuum Valve or Approved Equivalent

1"-90° bronze fitting (Typ)

1"-bronze nipple (Typ)

1 1/4" x 1" Bronze threaded union

Copper pipe (0.182" wall thickness) per AWWA C800 with plastic encasement; maintain upward grade from corporation stop to Air/Vacuum Combination valve

**NOTES:**

1. Maintain a grade upward from corp. stop to air valve.
2. Flare or solder joint fittings and compression fittings are acceptable.
3. Provide 3'x3'x3' of 1/2" crushed aggregate for drainage and support under valve, compact to 95%.
4. Detail not for use in roadways.

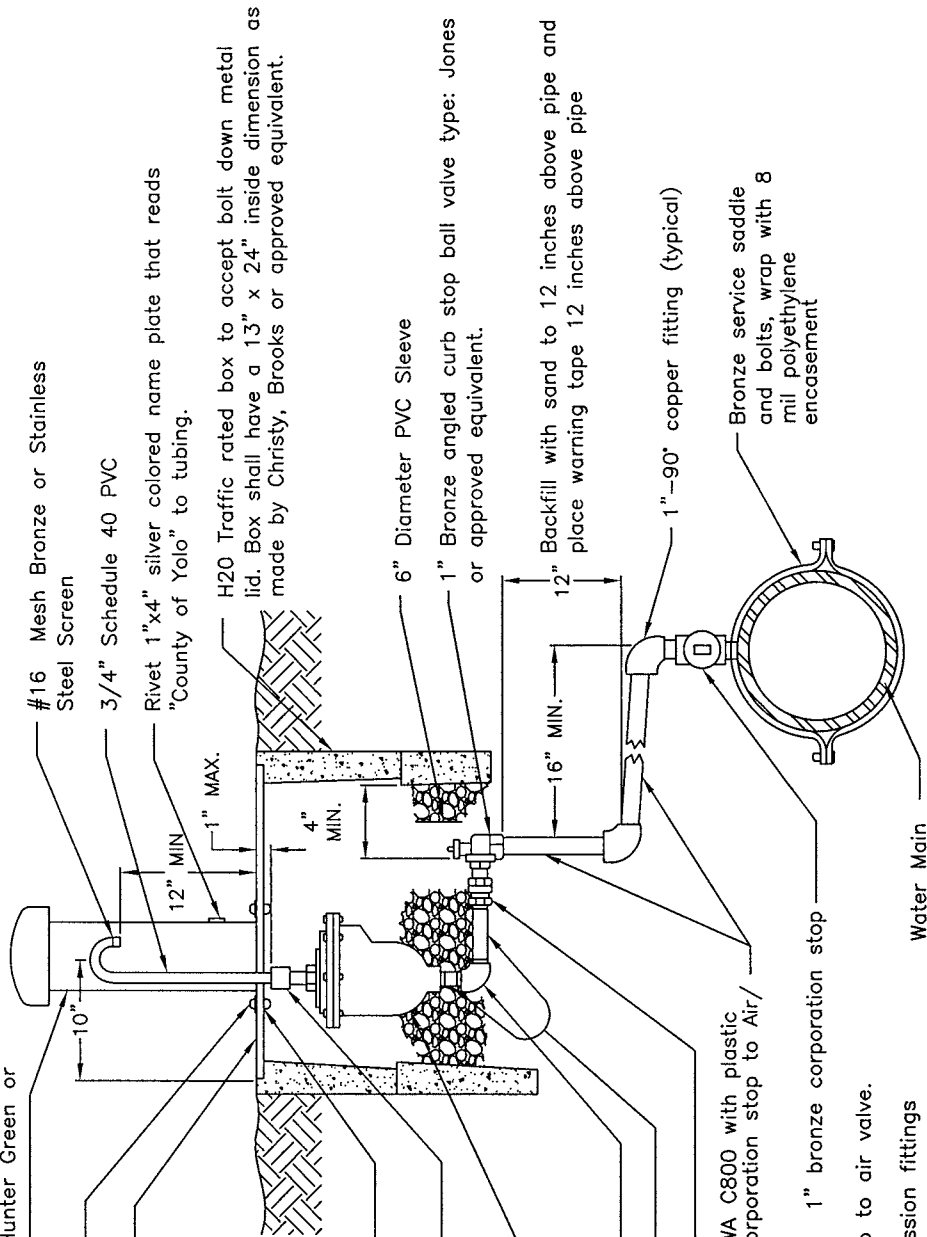

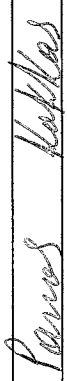
COUNTY OF YOLO PLANNING AND PUBLIC WORKS DEPARTMENT		DATE: 08/05/08
COMBINATION AIR/VACUUM VALVE		SHEET # 1 OF 1
 COUNTY ENGINEER No. C42401		DRAWING #: <b>8-14</b> NOT TO SCALE
APPROVAL DATE 28 Aug 08		

**NOTES:**

1. TEE AND MJ X FLANGE ADAPTER SHALL BE WRAPPED WITH 8 MIL POLYETHYLENE ENCASUREMENT
2. DIG SUMP UNDER CUT IN LOCATION AND PUMP ALL WATER FROM EXISTING MAIN AWAY FROM CUT IN LOCATION. DO NOT ALLOW ANY WATER TO ENTER EXISTING PIPE. ADHERE CHLORINE TABLETS TO TEE OR CROSS. THE NUMBER OF TABLETS SHALL BE IN ACCORDANCE OF THE COUNTY STANDARDS. SPRAY EXISTING PIPE, ALL FITTINGS AND VALVES WITH A SOLUTION OF SUPER CHLORINATED WATER JUST PRIOR TO INSTALLATION.
3. PROVIDE RESTRAINT OF PIPE JOINT AS REQUIRED BY PLANS AND DRAWING 8-3 SHEET 1.

FOR TEE INSTALL THRUST BLOCK. SIZE PER DRAWING 8-3 SHEET 1. FOR CROSS PROVIDE PIPE RESTRAINT AS REQUIRED PER PLANS.

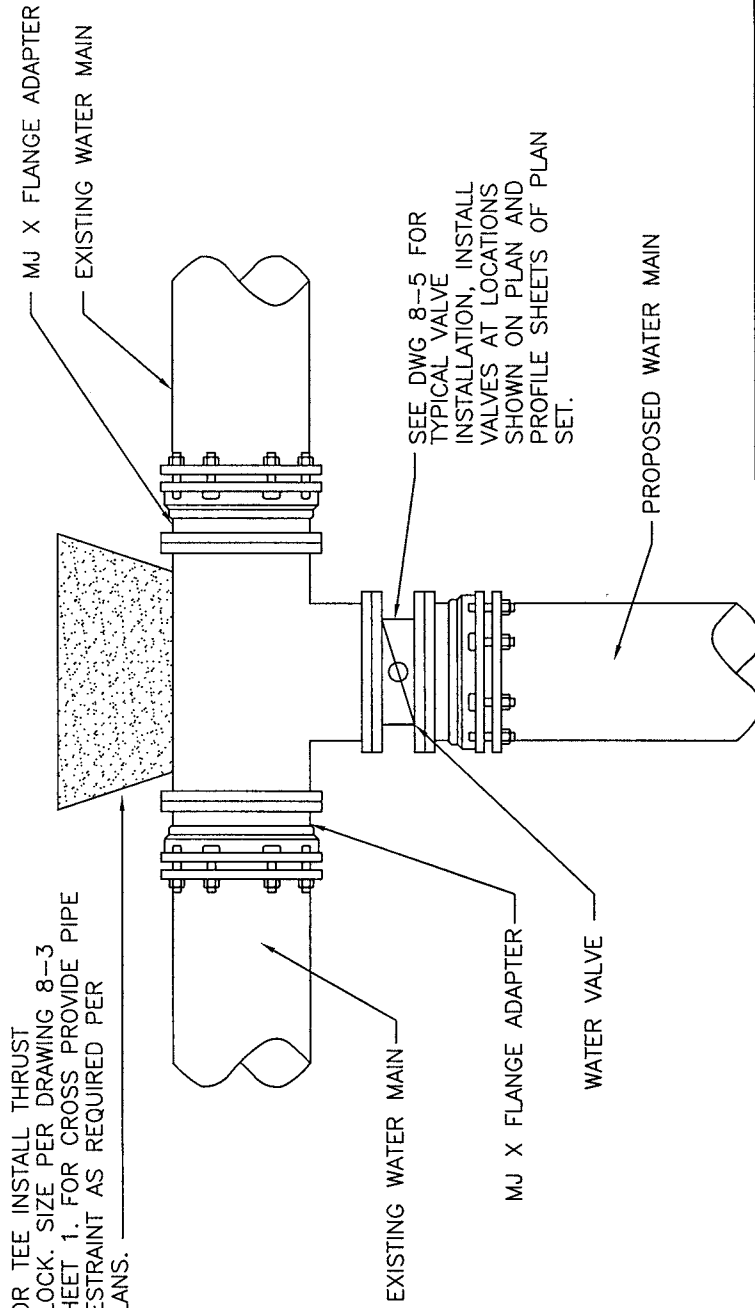

COUNTY OF YOLO PLANNING AND PUBLIC WORKS DEPARTMENT	DATE: 08/05/08
CUT IN	SHEET # 1 OF 1
<i>Panas Kalkas</i> COUNTY ENGINEER No. C42401	DRAWING #: 8-15 NOT TO SCALE
<i>28Aug.08</i> APPROVAL DATE	

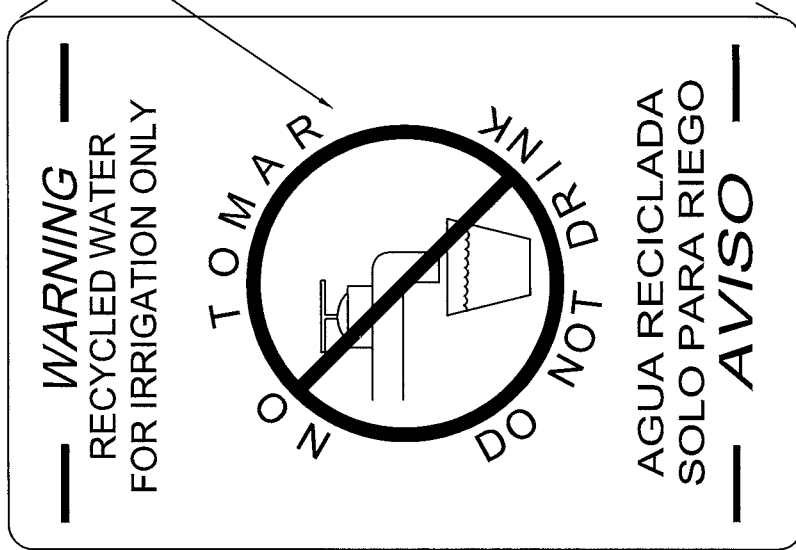

SIGN, LETTER HEIGHTS, AND SYMBOL SIZE SHOWN ARE IN REQUIRED PROPORTIONS

**NOTES:**

1. 12" x 18" ALUMINUM STEEL ALLOY 6061-T6 0.080" GAUGE, ROUNDED CORNERS (1" RADIUS).
2. LETTER HEIGHT AND SYMBOL SIZE SHALL BE PROPORTIONAL TO SIGN SIZE.
3. LETTER AND SYMBOL SHALL BE WHITE IN COLOR. THE BACKGROUND SHALL BE PURPLE (PANTONE 241) IN COLOR.
4. 4"x4" POST SHALL BE TREATED DOUGLAS FIR (STATE OF CALIFORNIA SPECIFICATION NO. 56-2.02B).
5. FOOTING SHALL BE 24" IN DEPTH WITH COMPACTED EARTH IN 4" LIFTS OR CONCRETE.
6. 5/16"Ø x 4-1/2" ZINC PLATED STEEL BOLT WITH VANDAL PROOF NUTS.
7. ALL SIGNS SHALL CONFORM TO THE STANDARD SPECIFICATIONS. A DIRECT OR PRESSURE SENSITIVE DECAL INK SCREENING PROCESS REQUIRED.
8. 3" x 4-1/2" PRESSURE SENSITIVE DECALS ARE REQUIRED FOR IRRIGATION CONTROLLERS AND OTHER ABOVE GROUND FACILITIES REQUIRING A WARNING SIGN. WHEN CONDITIONS AND/OR FACILITY CHARACTERISTICS RENDER THESE SPECIFICATIONS INAPPROPRIATE, ALTERNATIVE SIGNING MUST BE SUBMITTED FOR REVIEW AND APPROVAL BY THE COUNTY ENGINEER.

PLANNING AND PUBLIC WORKS DEPARTMENT	COUNTY OF YOLO	DATE:	08/05/08
NONPOTABLE RECYCLED WATER WARNING SIGN		SHEET #	1 OF 1
<i>Parras Kallas</i> COUNTY ENGINEER No. C42401	28 AUG 08	DRAWING #:	8-16
	APPROVAL DATE		NOT TO SCALE

**SECTION 9**  
**STORM DRAINAGE**

<b>CONTENTS</b>	<b>Page</b>
9-1 General Requirements.....	9-1
9-2 Definitions .....	9-2
9-3 Federal Flood Program .....	9-2
9-4 Drainage Diversions.....	9-2
9-5 Drainage Easements.....	9-3
9-6 Stormwater Detention and Storage .....	9-3
9-7 Design Computation .....	9-4
9-8 Design Runoff.....	9-5
9-10 Closed Conduits .....	9-6
A. Material.....	9-6
B. Cover Requirements .....	9-6
C. Trench Requirements.....	9-8
D. Spacing Requirements .....	9-8
E. Alignment Requirements .....	9-8
F. Velocity.....	9-8
G. Entrances and Exits.....	9-9
H. Water and Soil Tight System Testing .....	9-9
I. Jack and Bore Pipe.....	9-10
9-11 Manholes.....	9-10
9-12 Junction Boxes .....	9-11
9-13 Inlets.....	9-11
9-14 Pipe Stubs .....	9-13
9-15 Headwalls, Wingwalls, Endwalls, Trash Racks, Access Control Racks And Railings .....	9-13
9-16 Drainage Pumps .....	9-14
9-17 Open Channels.....	9-14
9-18 Outfall Design.....	9-15
9-19 Fencing Requirements .....	9-15
9-20 Cross Culvert Criteria .....	9-16
9-21 Drainage Along Class “C” Streets .....	9-16

## SECTION 9 STORM DRAINAGE

### **9-1 GENERAL REQUIREMENTS**

- A.** The planning, design and construction of local drainage facilities and other related appurtenances to be owned, operated, and/or maintained by the County of Yolo shall comply with these standards.
- B.** Design rainfall data is provided in the “Yolo County City/County Drainage Manual”, and is incorporated herein by reference.
- C.** The “Yolo County City/County Drainage Manual” provides guidance for the planning, design, and construction of regional drainage facilities serving multiple communities, and may be referenced for criteria not addressed in these standards.
- D.** A registered Civil Engineer shall stamp and sign all design calculations prior to submission for plan review. All work shall be in accordance with these design standards and standard engineering practice.
- E.** The County Engineer shall decide all questions of interpretation of "good engineering practice" guided by the standards and manuals of the discipline in question.
- F.** All drainage facilities shall be located within County roads and streets or publicly dedicated easements unless otherwise approved by the County Engineer. Adequate access for maintenance of the system shall be provided.
- G.** All new habitable structures shall be protected from the 100-year (1%) flood event and all public roads are protected from the appropriate design flood events, unless more stringent standards are required by state law.
- H.** Finished floor elevations shall be set at least one foot (1') above the 100-year floodwater surface.
- I.** The design of a new storm drain system shall include consideration of the downstream creek or storm drain. The Design Engineer shall show that the existing storm water system can convey the proposed drainage without adverse upstream, downstream and adjacent impacts and that the upstream, downstream or adjacent facilities are being improved to carry post project flows.
- J.** Any development within a drainage area, for which the Board of Supervisors has adopted a drainage plan pursuant to Yolo County Code Section 8-1.1601, shall pay the required fee prescribed in the plan prior to approval of a Final Map or Parcel Map.
- K.** Development shall not:
  - 1. Result in any new or additional expense to any person other than the developer or beneficiary for flood protection or for lost environmental stream uses and functions; nor
  - 2. Significantly increase flood elevations or decrease flood conveyance capacity upstream or downstream of the development; nor
  - 3. Pose any new or additional increase in flood velocity or impairment of the hydrologic and hydraulic functions of streams and flood plains unless a watershed benefit is realized; nor
  - 4. Significantly degrade surface or ground water quality
- L.** A Developer must demonstrate to the County Engineer’s satisfaction that for all storm events, up to and including the critical duration 100-year event, the grading activity does not:
  - 1. Result in an increase in peak release rate; and,
  - 2. Result in a time decrease associated with the time of concentration; and,
  - 3. Contribute to adjacent flood problems; and,

4. Significantly alter the direction of runoff.
- M. Stormwater facilities shall be functional before building permits are issued in residential and nonresidential subdivisions.

## **9-2 DEFINITIONS**

The following terms, abbreviations or definitions shall apply and the intent and meaning shall be interpreted as stated herein wherever they are encountered in these standards or in any documents or instruments referenced by these standards unless otherwise approved by the County Engineer.

<b><u>Abbreviation</u></b>	<b><u>Description</u></b>
<b>ASTM</b>	American Society for Testing and Materials.
<b>FEMA</b>	Federal Emergency Management Agency.
<b>Right-of-Way</b>	A strip of land dedicated, condemned or reserved for public use.
<b>Drainage Easement</b>	A strip of land dedicated, condemned or reserved for drainage use.
<b>Overland Release Path</b>	An alignment that allows the passage of floodwater through a development without damaging structures.

## **9-3 FEDERAL FLOOD PROGRAM**

- A. The County of Yolo is a participant in the National Flood Insurance Program and all development in the County shall comply with the regulations of the Federal Emergency Management Agency (FEMA). Amendments or revisions of FEMA flood maps will be required for all commercial and subdivision development located in a federal Special Flood Hazard Areas (Zones A, AO, A1-30, AH, A99, or AE) flood zone. Petitions for a Letter of Map Amendment (LOMA) or Letter of Map Revision (LOMR), including any fee required by FEMA, shall be submitted to the Department before improvement plans are approved. These regulations do not preclude the Department from requiring additional standards to protect the public from projected runoff.
- B. Fill for the removal of land from a designated FEMA 100-year floodplain, or a watercourse where building pads will be created, must be compacted to 95 percent (95%) of the maximum density obtainable with the modified proctor test method (ASTM Standard D-1557) or an equivalent test method.

## **9-4 DRAINAGE DIVERSIONS**

- A. The diversion of natural drainage is allowable only within the limits of the proposed improvement. All drainage must enter and leave the improved area at its original horizontal and vertical alignment unless an agreement, approved by the County Engineer, has been executed with the adjoining property owners or drainage is being discharged into a public right-of-way or other existing drainage feature.
- B. Temporary drainage diversions during construction may be approved by the County Engineer and shall be located and constructed in such a fashion as to permit their removal when necessary for the prevention of damage to adjoining properties.

**9-5 DRAINAGE EASEMENTS**

- A. Publicly owned drainage conduits and channels will not be allowed on private property, however in unusual circumstances, where the County Engineer or designee has given prior approval, storm drain facilities may be placed in easements. Such easements must be wide enough to accommodate normal construction equipment and shall be easily accessible to such equipment as necessary to construct, operate and maintain the facility. The easement shall be offered to the County of Yolo or other public entity responsible for storm drainage system operation and maintenance.
- B. Where improvements fall on adjacent property (such as daylighting ditch profiles) written permission from the adjacent property owner(s) for such construction shall be required. A copy of the documents which grant such approval shall be submitted to the County Engineer before approval of the improvement plans.
- C. When storm water discharge from a proposed upstream development enters a downstream conveyance on private property, the Department may require that the Developer obtain an easement to be publicly dedicated for operation and maintenance of the conveyance.
- D. In the event necessary permanent offsite easements cannot be acquired through negotiation, the County will condemn necessary rights-of-way providing the person, firm, or corporation requesting such condemnation enters into a written agreement to pay all costs and expenses of the condemnation. The agreement shall require a cash deposit that will consist of the estimated cost of condemnation plus 50%, including, but not limited to, land or easement purchase cost, temporary construction easements, staff, appraiser and attorneys fees. It shall require payment of all costs and expenses of the deposit as specified by the County. Any unspent funds will be returned.
- E. Acquisition and maintenance of temporary construction easements outside of the limits of the subdivision shall be the Developer's responsibility.
- F. Easements for storm drains shall meet the following width criteria:
  - 1. All easements for closed conduits shall have a minimum width equal to the greater of fifteen feet (15') or the required trench width according to the standard detail for pipe bedding and initial backfill plus two feet (2') of additional width for every foot of depth as measured from the bottom of the pipe to finished grade, whichever is greater. Exceptions to the minimum width require approval by the County Engineer.
  - 2. All conduits shall be centered within their easements.
  - 3. Drainage easements for open channels shall have sufficient width to contain the ultimate channel, fencing where required and a twenty-foot (20') service road with drainage ditch. Additional width shall be provided to allow equipment to safely negotiate the service road for the purposes of construction, operations and maintenance activities.
  - 4. Easements shall not be split along property lines.

**9-6 STORMWATER DETENTION AND STORAGE**

- A. Sufficient stormwater detention volume shall be provided such that the probability of the post development release rate exceeding 0.1 cfs/acre of development shall be less than one percent (1.0%) per year. The stormwater detention volume shall not be less than the difference between pre- and post- development flows from the development site in the 100-year, 24 hour storm event.
- B. Stormwater detention facilities shall be designed and constructed with the following characteristics:



1. Maximum side slopes of 1(vertical):3(horizontal), unless flatter slopes are indicated due to geotechnical conditions.
  2. Minimum 1 foot freeboard provided at design capacity, or as needed to account for wave action anticipated due to special wind conditions.
  3. Detention pond bottoms shall be sloped at 2%; flatter slopes may be allowed by the County Engineer in special cases.
  4. The detention facility shall be accessible in all weather conditions for maintenance personnel and equipment, and shall be designed to be easily maintained.
  5. Detention facilities shall provide an overflow structure and overflow path that can safely pass excess flows through the development site. Overflow elevation and route to be at least 1' below any top of foundation of development and nearby existing structures. The minimum design rate for overflows shall be 1.0 cfs/acre of area tributary to the detention facility.
  6. All outlet works shall function under gravity, without human intervention or outside power and shall operate with minimum maintenance, unless approved by the County Engineer.
  7. Water surface depths two feet above the base flood elevation will not damage the detention facility.
  8. Detention facilities shall facilitate sedimentation and catchment of floating material.
  9. Detention facilities shall minimize impacts of stormwater runoff on water quality by incorporating Best Management Practices.
  10. Detention facilities shall store the required site runoff under all stream flow and backwater conditions up to the base flood elevation.
  11. Detention facilities shall not allow design release rates to be exceeded under any stream elevation less than the base flood elevation.
  12. The detention facility shall be designed to allow for the 2- year predevelopment storm event flows to bypass the basin. When overland channels are required in basins, they shall be concrete lined, and shall not conflict with other potential uses of the basin.
- C.** Developments with stormwater detention facilities that have off-site flow tributary to the site either shall provide detention sufficient to accommodate runoff from the off-site tributary watershed and the site, or shall store the site runoff and convey off-site flows through the development while preserving the existing flow and storage of the site.
- D.** Stormwater detention facilities may be located off-site if the following conditions are met:
1. The off-site detention facility meets all of the requirements of these Improvement Standards;
  2. Adequate detention capacity in the off-site facility is dedicated to the development; and
  3. The development includes provisions to convey stormwater to the off-site detention facility.
- E.** Detention pond fencing shall comply with Section 9-19.

#### **9-7 DESIGN COMPUTATION**

- A.** The “Yolo County City/County Drainage Manual” provides design rainfall data for use throughout Yolo County.
- B.** All drainage systems shall be designed to accommodate the ultimate development of the entire upstream watershed. The peak discharge from the 10-year design storm shall be used in the

design of local drainage systems components (closed conduits and gutters.) All open channel drainage systems shall be designed for both the 10-year and the 100-year frequency design storm conditions, with freeboard as required by the County Engineer.

- C.** The Design Engineer shall design an overland release path which ensures that the 100-year-design storm flows through the proposed development will prevent flooding to existing and proposed structures in the event of malfunction or overloading of the drainage system. The overland release path shall be shown on the grading plan for the project. The overland release path shall be designed and constructed in a manner to transport the peak rate of runoff from the 100-year frequency storm falling on fully developed and saturated tributary watershed. Streets, parking lots, playgrounds, pedestrian areas, pedestrian walkways, utility easements and other open space areas may be considered compatible uses with the overland release.
- D.** The design computations for drainage shall include the following information that shall be submitted before the plans will be accepted for checking:
1. Topographic map showing existing and proposed ground elevations that show on-site and off-site watershed boundaries draining onto the site. It shall also include total and sub-shed areas in acres.
  2. Quantity of flow (cfs) to each structure with corresponding area and land uses that generate the quantity.
  3. Quantity of flow (cfs) in each pipe.
  4. Flow line elevation of manhole or structure.
  5. Top of structure elevation.
  6. Hydraulic grade line elevation at each structure.
  7. Hydraulic gradient.
  8. Pipe size, type, class, length and gradient.
  9. Channel dimensions, flow and water surface profile computations.
  10. Electronic copies of all computer input files used for analysis and design on an acceptable electronic media.

### **9-8 DESIGN RUNOFF**

- A.** For all watersheds greater than 10 acres, design runoff volumes shall be calculated using continuous simulation or event hydrograph methods. If event hydrograph methods are used to calculate design runoff volumes, they must be either HEC-1 SCS runoff method with outlet routing option, TR-20 with outlet control routing option, or TR-55 tabular method with outlet control routing, HEC-HMS, HEC-RAS, or EPA Storm Water Management Model (SWMM). Event methods shall incorporate the following assumptions:
1. Antecedent moisture condition = 2; and
  2. Huff or SCS Type II rainfall distribution; and
  3. Twenty-four (24) hour duration storm with a one percent (1.0%) probability of occurrence in any one year.
- B.** For sites where the undeveloped release rate is less than the maximum release rate of 0.1 cfs/developed acres, the developed release rate and corresponding site runoff detention volume shall be based on the existing undeveloped release rate for the development site.

- C. All hydrologic and hydraulic computations must be verified under the full range of expected downstream water surface elevations, from low flow through the base flood elevation.
- D. Responsibility for maintenance all detention facilities shall be provided for either through the establishment, or incorporation into, a County Service Area, or establishment of a financing mechanism with Conditions, Covenants and Restrictions recorded against the properties served by the facility.
- E. The longest flow paths shall be documented and shown on watershed map.

### **9-9 HYDRAULICS**

All storm drain pipelines and open channels shall be designed to convey the design peak runoff and shall conform to the following requirements:

- A. **Hydraulic Grade Line** – The hydraulic grade line for the 10-year discharge shall be a minimum of one foot below all inlet grates, manhole covers, and all other drainage structures in the system. The hydraulic grade line shall be shown on the plans when it is above the top of the pipe.
- B. **Manning's Formula** - The "n" value used in Manning's formula shall conform to the following:
  - 1. Manning's formula shall be used to compute capacities of all open and closed conduits other than culverts.
  - 2. A minimum "n" value of 0.015 shall be used for sizing conduits.
  - 3. Minimum velocity in closed conduits shall be 2.5 feet per second. Maximum velocity shall be 5 feet per second. Velocities shall be based on full flow conditions.
- C. A flap gate shall be installed in all laterals that flow into a mainline storm drain whenever the hydraulic grade line of the main line is higher than the surrounding area drained by the lateral. The flap gate must be set back from the main line drain so that it will open freely and not interfere with the main line flow. A junction structure shall be constructed for this purpose.

### **9-10 CLOSED CONDUITS**

The specific type of pipe to be used in the development shall be shown on the plans. The minimum inside diameter for storm drain pipes shall be eighteen inches (18"). No storm drain conduit shall have a diameter less than that of the conduit immediately upstream of it. Drainage systems shall be constructed of the following materials.

- A. **Material**
  - 1. Reinforced Concrete Pipe - Class III reinforced concrete pipe, minimum, conforming to ASTM C76, latest revision. The Design Engineer shall specify on the plans that the assembly of joints shall be in accordance with the pipe manufacturer's recommendations and the requirements of ASTM C 443.
  - 2. High Density Polyethylene Pipe
    - a. High Density Polyethylene Pipe (HDPE) may be used upon written approval of the County Engineer, and shall be backfilled with lean concrete backfill.
    - b. HDPE pipe shall be double wall, ribbed, meeting the requirements of ASTM F 667, with splice collars and flared end sections.
  - 3. Corrugated Metal Pipe
    - a. Corrugated Metal Pipe may only be used for private driveway cross culverts and shall be privately owned and maintained by the adjacent property owner.
    - b. Corrugated metal pipe shall be 16 gauge (minimum) corrugated steel, with splice collars and flared end sections.
- B. **Cover Requirements** At locations where the minimum cover requirements cannot feasibly be obtained, the conduit shall be either encased in concrete or provided with a concrete cover or other

methods of pipe protection as approved by the County Engineer. Cover shall be measured from the top of a rigid pavement or the bottom of a flexible pavement.

1. Minimum and Maximum Cover - The minimum cover height shall be per Table 9-1. The maximum cover shall be per Table 9-2.

<b>TABLE 9-1 MINIMUM PIPE COVER REQUIREMENTS</b>	
<b>Pipe Material Type and Location</b>	<b>Minimum Cover Requirement</b>
Reinforced Concrete under rigid pavements	A nine-inch (9") space between top of pipe collar and bottom of slab consisting of compacted granular fill shall be maintained at a minimum.
Reinforced Concrete in unpaved areas and under flexible pavements	1/8 the diameter or rise (the greater of) but not less than twelve inches (12")
Corrugated Metal or Ribbed HDPE driveway cross culverts	Twelve inches (12") gravel or earth Six inches (6") asphalt or Portland cement concrete
Note: All depths shown are for a minimum trench width equal to the outside diameter of the pipe plus sixteen inches (16") measured at the top of the pipe collar.	

<b>TABLE 9-2 MAXIMUM PIPE COVER REQUIREMENTS – CONCRETE PIPE</b>						
<b>DIA.</b>	<b>RCP</b>					<b>Cast In Place</b>
	<b>Class</b>					
	<b>I</b>	<b>II</b>	<b>III</b>	<b>IV</b>	<b>V</b>	
<b>12</b>	Not Permitted	Not Permitted	12	30	No Limit	Not Permitted
<b>15</b>			15	35		
<b>18</b>			16	38		
<b>21</b>			17	39		
<b>24</b>			18	39		
<b>27</b>			19	39		
<b>30</b>			19	38		
<b>33</b>			20	38		
<b>36</b>			17	27	69	
<b>42</b>			18	29	62	
<b>48</b>			19	30	60	
<b>54</b>			20	31	58	
<b>60</b>			21	31	57	
<b>66</b>			22	32	56	
<b>72</b>			23	33	56	
Note: 1. All depths shown are for a minimum trench width equal to the outside diameter of the pipe plus 24" measured at the top of the pipe. 2. Depths are measured to bottom of trench in feet.						

2. Temporary Construction Vehicle Loading: A note shall be made on the plans stating the minimum cover requirements during construction for temporary construction vehicle loading. For metal pipes, place at least four feet (4') of cover over the top of the pipe. For reinforced concrete pipe, place at least three feet (3') of cover over the top of the pipe.

**C. Trench Requirements**

1. Trenches shall be excavated with full depth and vertical sides whenever possible.
2. The minimum trench width shall not be less than the outside diameter of the pipe barrel plus twenty four inches (24"), measured at the top of the pipe. The maximum trench width shall not exceed six (6) nominal pipe diameters, measured at the top of the pipe.
3. In fill areas, or in areas with poor soil conditions where it is anticipated that a good, firm, vertical-walled trench cannot be constructed, the Design Engineer shall design the pipe structural requirements in accordance with good engineering practice. A note shall be placed on the plans directing the contractor to place the proper strength pipe if trench conditions encountered differ from the design trench.
4. Where conditions require side sloping of trenches, the minimum vertical trench shall be from the bottom of the trench to one foot (1') over the top of the pipe.

**D. Spacing Requirements**

When multiple lines of pipes or pipe arches greater than forty-eight inches (48") in diameter or span are used, they shall be spaced so that the sides of the pipes shall be no closer than one-half diameter or three feet (3'), whichever is less, to permit adequate compaction of backfill material. For diameters less than forty-eight inches (48"), the minimum clear spacing shall not be less than two feet (2').

**E. Alignment Requirements**

1. The centerline of drainage pipelines in new streets shall be approximately one foot (1') from the flowline of the gutter, in front of the face of curb. Stormdrain pipes shall be placed to enter the curb inlets at the center of the box.
2. All new storm drains shall be placed a minimum of one hundred feet (100') from existing and proposed water wells. Encroachments less than one hundred feet (100') require approval of the County Environmental Health Department prior to plan approval.
3. Meandering and unnecessary angular changes of pipelines will not be allowed. Angular changes, when necessary, shall be larger than 90 degrees.
4. Pipelines shall be laid straight in both horizontal and vertical planes between manholes unless otherwise approved by the County Engineer.
5. Pipeline Radius Criteria: Special permission must be granted by the County Engineer for any curved gravity pipes. The minimum radius of curvature shall be 200 feet, and shall be 30% larger than the radius of curvature recommended by the pipe manufacturer' for curved alignment. All curves, radii, length of pipe joints, and types of pipe shall be shown on the plans.
6. Where storm drain pipelines of different diameter join, the invert elevations shall be adjusted to maintain a uniform energy gradient.

**F. Velocity**

1. The minimum full flow velocity shall be no less than two and one half (2.5) feet per second, unless otherwise approved by the County Engineer. The maximum velocity shall be less than the critical velocity at full flow.
2. When full-flowing pipelines that produce velocities greater than five (5) feet per second are approved by the County Engineer, special provisions shall be taken to prevent erosion or pipe displacement and to keep the EGL contained underground.

**G. Entrances and Exits**

1. Headwalls and other structures shall be designed to increase hydraulic efficiency, prevent erosion adjacent to the conduit and provide a counterweight to prevent flotation.
2. Where exits are necessary, headwalls or flared end sections should be used for culverts. Where drainage systems discharge into a channel, standard headwalls shall be installed per the Caltrans Standard Plans. The vertical face of the headwall shall be set back a sufficient distance from the channel side slope to accommodate flap gates or duckbill-style check valves, as approved by the County Engineer, in a fully opened position without encroachment of the flap past the channel side slope face.
3. Energy dissipation shall be designed at outlets where velocities are erosive.

**H. Water and Soil Tight System Testing**

1. All storm drain pipe, manholes, and fitting connections shall be water and soil tight.
2. All stormdrain lines and manholes shall be tested for acceptability following placement of aggregate base, but prior to paving, using low pressure air, or hydrostatic testing. No sealant shall be used in any newly installed storm drain without the prior approval of the County Engineer. Using sealant in a storm drain is not the equivalent of a sound storm drain pipe. Structural repair work shall be approved by the County Engineer. The County inspector shall witness all low-pressure air tests and verify the accuracy and acceptability of the equipment utilized.
3. Table 9-3 specifies minimum times required for a one pound per square inch, gauge (1 psig) pressure drop from a starting pressure of at least three and one-half pounds per square inch, gauge (3.5 psig) greater than the average back pressure of any groundwater above the pipe's invert.

<b>TABLE 9-3 MINIMUM TIME REQUIRED FOR A 1.0 PSIG PRESSURE DROP FOR LOW PRESSURE AIR TEST</b>											
Pipe Dia. (in.)	Min. Time (minutes)	Length for Minimum Time (ft)	Time for Longer Length (sec)	Minimum Time for Length (L) Shown (minutes:seconds)							
				100	150	200	250	300	350	400	450
12	11:20	199	3.418L	11:20	11:20	11:24	14:15	17:05	19:56	22:47	25:38
15	14:10	159	5.342L	14:10	14:10	17:48	22:15	26:42	31:09	35:36	40:04
18	17:00	133	7.692L	17:00	19:13	25:38	32:03	38:27	44:52	51:16	57:41
21	19:50	114	10.470L	19:50	26:10	34:54	43:37	52:21	61:00	69:48	78:31
24	22:40	99	13.674L	22:47	34:11	45:34	56:58	68:22	79:46	91:10	102:33
27	25:30	88	17.306L	28:51	43:16	57:41	72:07	86:32	100:57	115:22	129:48
30	28:20	80	21.366L	35:37	53:25	71:13	89:02	106:50	124:38	142:26	160:15
33	31:10	72	25.852L	43:05	64:38	86:10	107:43	129:16	150:43	172:21	193:53

36	34:00	66	30.768L	51:17	76:55	102:34	128:12	153:50	179:29	205:07	230:46
----	-------	----	---------	-------	-------	--------	--------	--------	--------	--------	--------

4. For hydrostatic testing, the water exfiltration for any length of the storm drain pipe between manholes shall be measured and shall not exceed five hundred (500) gallons per inch of internal pipe diameter per mile of pipe per day. During exfiltration testing, the maximum internal pipe pressure at the lowest end shall not exceed eleven feet (11') of water or 5.0 psi and the internal water head shall be two feet (2') higher than the top of the pipe or two feet (2') higher than the ground water level, whichever is greater. Vacuum go/no-go testing method or alternate testing methods may be submitted for thirty-inch (30") or greater internal diameter pipes.
5. A note shall be placed on the improvement plans stating these requirements and that the contractor is responsible for providing equipment and labor for performing tests and making measurements when directed to do so by the County’s inspector.

**I. Jack and Bore Pipe**

Where use of conductor casing is specified, the casing shall be reinforced concrete pipe, or welded steel pipe. The casing shall be of sufficient diameter to allow dry sand to be blown into the void between the carrier and the conductor and to allow adjustment of the carrier pipe to grade. Normally, an inside diameter of the casing that is six inches greater than the outside diameter of the couplings of the storm drain pipe is sufficient. Welded steel conductor pipe shall have a minimum wall thickness of ¼ inch for sizes up to and including 24 inches in diameter and 5/16 inch for sizes 27 inches to 36 inches in diameter. Every reinforced concrete pipe conductor must be designed for the loading condition and, if jacked, the additional loading imposed by the jacking operation.

Direct dry boring of reinforced concrete pipe and of the portion of storm drain pipes which pass beneath curbs and gutter, sidewalks, and other obstructions, up to a maximum length of 15 feet, is permissible. Installation and other material specifications shall conform to the requirements of the Caltrans Standard Specifications.

Backfill in bore pits shall be given special attention with respect to preventing structural failure of the pipe entering or exiting the conductor, and adequate bedding and initial backfill shall be specified. The ends of the casing shall be sealed to the storm drain pipe to prevent loss of the sand packing. Voids created outside the casing due to cave-ins shall be backfilled to the satisfaction of the County Engineer.

**9-11 MANHOLES**

- A. Standard precast concrete manholes shall be used except where special manholes or junction boxes are required. The design must be submitted to the County Engineer for approval. In no case will junction boxes or manholes be allowed which are smaller than forty-eight inches (48") greatest inside dimension. Precast concrete manholes shall be manufactured in accordance with ASTM C 478.
- B. Manholes shall be located at junction points, and changes in conduit size. On curved pipe lines, manholes shall be placed at the B.C. and E.C. and on 200-foot maximum intervals along the curve.
- C. Spacing of manhole, junction boxes or inlets of such size as to be accessible for maintenance shall not exceed 400-feet for drains between eighteen inches (18") and forty-eight inches (48") in diameter, and 500-feet for pipes equal to or greater than fifty-four inches (54") in diameter. The

spacing of manholes shall be nearly equal whenever possible. Manholes shall not be placed in roadway intersections unless necessary as a junction point.

- D. All manholes and junction boxes other than inlets shall have standard manhole frames and covers as shown in Standard Drawings 9-3 and 9-4. Manholes will not be allowed in the gutter flow line.
- E. Slotted manhole covers may be used to pick up minor drainage in non-traffic areas. Covers shall conform to Standard Drawing 9-5.
- F. Improvement plans shall include a special detail for all manholes at junction points where there is a change in pipe direction and pipe diameter exceeds forty-eight inches (48").
- G. The maximum 24” barrel section height is twelve inches (12”).
- H. Resilient connectors are required between the manhole and pipe as shown in Standard Drawing 9-14. The resilient connector shall be manufactured in accordance with ASTM C 923. Use of non-shrinking or expansive grout for making connections of pipe and water stop to manhole walls is required.
- I. Preformed plastic gaskets are required between manhole barrel sections.

**9-12 JUNCTION BOXES**

Drop inlets may be used as junction boxes provided that no pipe entering or leaving the box is larger than 18 inches inside diameter. For any junction box with a pipe 21 inches or larger in diameter, the inlet shall have a manhole base and top slab. The inlet shall be mounted on top of the top slab. All other non-inlet junction boxes shall conform to the requirements for manholes. All junctions shall be located in drop inlets or manholes.

**9-13 INLETS**

Typical curb inlets shall be Caltrans Type “GO” precast curb inlet as shown on Standard Drawing 9-6, with guard rod.

Requirements for inlets are as follows:

- A. Inlets shall be placed so that the length of flow in the gutter does not exceed 300-feet. Exceptions to the 300-foot limit may be granted by the County Engineer, provided the Design Engineer submits hydrology calculation to the satisfaction of the County Engineer that show street inundation will not exceed the limits shown in Table 9-3.

<b>TABLE 9-3 ALLOWABLE STREET INUNDATION</b>		
<b>Street Type</b>	<b>10-Year Storm</b>	<b>100-year storm</b>
Local Residential, Primary Residential	<p><u>At continuous grade:</u> Travel lanes remain clear and do not carry storm water.</p> <p><u>At sag points:</u> Stormwater elevation shall not exceed top back of curb or sidewalk elevation. Maximum depth in travelled way shall be 6 inches.</p>	<p><u>At continuous grade:</u> Minimum depth at gutter flow line shall not exceed 4” above the top back of curb or a maximum of 10”. Maximum depth at centerline shall be 4 inches.</p> <p><u>At sag points:</u> Stormwater shall be a minimum of one foot below building pads. Ponding shall not extend more than 120’ from inlet along any street segment.</p>



	Centerline shall be dry.	
Collector, Industrial	Same as above	Storm water flow is contained within the right of way. The center 12' of roadway shall remain clear of storm water.
Arterials		Storm water flow is contained within the right of way. All travel lanes are clear of storm water flow. Bike lanes are allowed to be inundated.

- B. Inlets shall be placed to minimize the gutter flow at pedestrian crossings & ramps.
- C. The figure below is a cross section of a typical compound gutter.

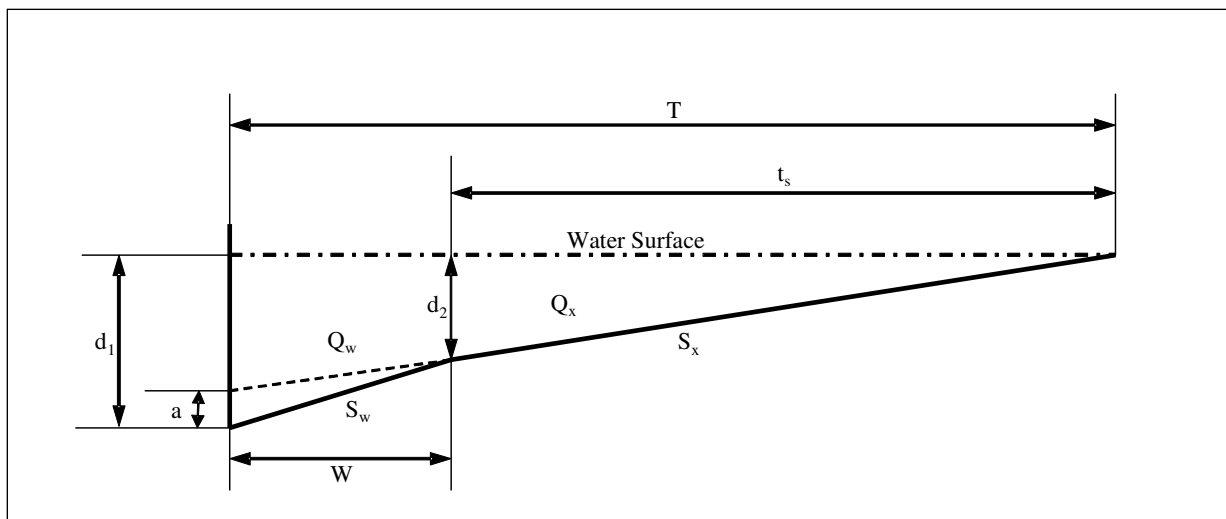

**Figure: Flow in Compound Gutters**

The equations for determining spread and depth in compound gutter sections are given below.

$$d_1 = TS_x + a \quad S_w = a/W + S_x \quad A = (T^2S_x + Wa)/2$$

$$d_2 = (T - W)S_x \quad t_s = (Q_s n / 0.56 S_x^{5/3} S^{1/2})^{3/8} \quad Q = Q_w + Q_s$$

$$Q_s = 0.56[(T - W)S_x]^{2.67} S^{0.5} / n S_x$$

$$Q_w = 0.56\{(TS_x + a)^{2.67} - [(T - W)S_x]^{2.67}\} S^{0.5} / n(a/W + S_x)$$

Where:

- T = width of flow or spread, ft
- Q = gutter flow rate, cfs
- S<sub>x</sub> = pavement cross slope, ft/ft (typically 0.02)
- W = width of depressed gutter section, ft
- S = longitudinal slope, ft/ft
- Q<sub>w</sub> = depressed section flow, cfs
- S<sub>w</sub> = depressed section slope, ft/ft
- a = gutter depression, ft

$d_1$  = depth of water at curb, ft

$d_2$  = depth of water at change in section slope, ft

$n$  = Manning's roughness coefficient (typically 0.016)

$Q_s$  = gutter capacity above depressed section, cfs

$t_s$  = width of flow or spread beyond depressed section, ft

- D.** A clogging factor of fifty percent (50%) shall be used when computing the interception capacity of the inlet.
- E.** The connector pipe from inlets at sag points shall be sized to accommodate the design runoff taking into consideration by-pass flow from upstream inlets.
- F.** Curb opening catch basins with grating(s) and debris skimmer (Standard Plans for Public Works Construction (Greenbook) drawings 300-2 & 301-2) shall be used in locations where additional inlet capacity is required. The inlet width can vary from seven feet (7') to twenty-eight feet (28') and in the number of grates too. The H dimension is the gutter depression depth and shall be a standard two inches (2").
- G.** Inlets in streets shall be placed at the extension of side lot lines in residential subdivisions, except at intersections where they shall be placed at the curb return.
- H.** The minimum gutter slope on new streets shall be 0.65 percent (.0065).

#### **9-14 PIPE STUBS**

The criteria for pipe stubs shall be as-follows:

- A.** Temporary pipe stubs shall be two (2) sizes larger than the permanent pipe and a flared end section or a corrugated drop inlet shall be used at the entrance.
- B.** A headwall and trash rack shall be required where the upstream pipe ends at a park or open field.
- C.** Whenever a pipe stub is required, all ditches and swales shall be "trained" toward the stub.
- D.** Pipe stubs shall be as deep as possible to provide for future extension.
- E.** Flared end sections shall be required for the upstream/downstream end of a pipe system that does not connect to an existing pipe system or channel.

#### **9-15 HEADWALLS, WINGWALLS, ENDWALLS, TRASH RACKS, ACCESS CONTROL RACKS AND RAILINGS**

The requirements for these facilities are as follows:

- A.** All headwalls, wingwalls and endwalls shall be considered individually and in general shall be designed in accordance with retaining wall details in the Caltrans Standard Specifications and Plans .
- B.** Trash racks will be provided where they are necessary to prevent clogging of culverts and storm drains and eliminate hazards. Trash racks shall be designed such that the ratio of trash rack open area to drain opening is at a minimum four to one (4:1). Trash racks shall be designed to facilitate maintenance in both the dry and wet conditions.
- C.** Operable access control racks shall be required on pipes eighteen inches (18") or larger and shall be designed such that the ratio of access control rack open area to drain opening is at a minimum four to one (4:1). Access control racks shall be hinged and lockable.
- D.** The County Engineer may require metal beam guardrail, handrails, or chain link fencing at culverts, headwalls, box culverts, and on steep side slopes. Installation shall be in accordance with the Caltrans Standard Specifications and Plans.

**9-16 DRAINAGE PUMPS**

Drainage pumping plants are generally discouraged, and require that a funding mechanism be established to operate, maintain, and replace the equipment. Drainage pumping plants shall be designed in accordance with the latest edition of the Hydraulic Institute Standards and as specified by the County Engineer. In addition to the requirements for wastewater pumping stations described in Section 7, consideration shall be given to the following minimum criteria:

- Redundant pumping capability.
- Back up power supply, using natural gas or propane (LPG) driven engines.
- Trash cleaning from waste stream during pumping operations.
- Automate control system and telemetry for alarm notification, including integration into any existing SCADA system.
- Minimum life-cycle costs for the pumping facilities including construction costs.
- Site security and lighting.
- Aesthetics such as landscaping and fencing.

**9-17 OPEN CHANNELS**

- A.** Open channels are required whenever one or more of the following applies:
1. The design flow rate exceeds the capacity of a seventy-two inch (72") pipe.
  2. The outfall is at an elevation such that minimum cover cannot be obtained over the pipe.
  3. County policy, or project approvals, require the channel to remain natural.
- B.** Open channels shall consist of natural earth channels, lined bottom channels or concrete lined channels as approved by the County Engineer.
- C.** Criteria for open channels shall be as follows:
1. Open channel design shall include a water surface profile analysis using the Corps of Engineers HEC RAS computer program or their UNET program or other hydraulic program, if approved by the County Engineer.
  2. Open channels shall be designed to convey the 100-year flood event with a minimum one-foot (1') of freeboard. The County Engineer or FEMA may specify additional levee and freeboard requirements.
  3. Minimum velocity: Two-feet per second (ft/s)
  4. Maximum velocity:
    - i. Earth channels, six ft/s
    - ii. Lined channels, ten ft/s
    - iii. Bottom-lined channels, eight ft/s
  5. The Design Engineer shall determine if super-elevating the outside bank on bends is required.
  6. The centerline curve radius of an open channel shall be equal to or greater than twice the bottom width (thirty -five foot (35') minimum).
  7. Natural earth channels shall be vegetated with native grasses or other permanent vegetative cover as determined by the County Engineer.

8. Channels shall be constructed to a typical cross section. Fully lined channels shall be required where side slopes are steeper than 3 horizontal to 1 vertical (3:1); channels with unlined sides shall be designed with side slopes of 3 horizontal to 1 vertical (3:1) or flatter. The County Engineer may approve exceptions. Standard Drawing 9-8 shall be used in the design of lined channels.
9. All channels shall have a minimum bottom width of six feet (6') and shall have access ramps for maintenance equipment. An access ramp may be required between each set of culverts or other above grade channel obstructions and at the upstream and downstream ends of the channel. Standard Drawing 9-9 shows the typical ramp and transition detail. A twenty foot (20') service road shall be provided having a sixteen-foot (16') improved surface and two-foot (2') shoulders on each side. Roads having a radius tighter than forty-two feet (42') shall require additional width as determined by the County Engineer.
10. For all channels, either improved or natural, the following items shall be shown on improvement plans in addition to information heretofore required:
  - i. Typical sections and cross-sections.
  - ii. Profile of the existing channel and top of bank profile for a minimum of 1,000-feet each side of the development in order to establish an average profile grade through the development.
  - iii. Interceptor Ditches - Interceptor ditches or approved alternates shall be placed at the top of the cut or bank where deemed necessary by the County Engineer to prevent erosion of the channel bank. Runoff shall not be allowed to "sheet drain" over top of bank.
11. Erosion Protection – All natural or graded surfaces disturbed by construction operations shall be protected from erosion by installation of temporary and permanent erosion control improvements. Standard Drawings 9-10 and 9-11 show details for both pipe and ditch discharge erosion.

### **9-18 OUTFALL DESIGN**

Requirements for outfall design are as follows:

- A. All drainage outfalls shall be shown in plan and profile on the improvement plans for a distance of 1,000 feet or until a definite "daylight" condition is established.
- B. All existing and proposed drainage ditches upstream and downstream of the improvement shall be shown on the plans and profile for a distance of at least 500 feet or until an average profile grade through the improvement is established.
- C. The profiles shall include ditch flow-line and top of bank elevations (right and left when different).
- D. When improvements have more than one unit or phase, the drainage outfall shall be shown as extending to the property boundary and beyond, if required, although it may not be constructed with the current unit development. All temporary outfalls shall be shown in both plan and profile on the improvement plans.

### **9-19 FENCING REQUIREMENTS**

The requirements for fencing (see Standard Drawing 9-12) shall be as follows:

- A. Detention facilities, pumping stations and improved channels exceeding four feet (4') in depth with side slopes steeper than 3:1 shall be fenced with six foot (6') chain link fence with slats or tubular steel open style fencing. The approval of the County Engineer is necessary for open style fencing other than chain link fencing.

- B.** In all other areas, fencing shall be placed only upon the recommendation of the County Engineer.
- C.** Drive gates shall be minimum 12-feet (12') wide, and walk gates shall be 4-feet (4') wide minimum. Drive gates shall be set a minimum of 20-feet (20') back from the edge of pavement to allow for a safe parking area off of the traveled way while opening /closing gates. AC paving shall be provided between the traveled way and drive gate. AC paving design shall be per Section 4 – “Transportation” of these Improvement Standards.
- D.** Fences shall be located 6-inches (6") inside the drainage right-of-way and easement lines and a minimum three feet (3') from top of bank.

#### **9-20 CROSS CULVERT CRITERIA**

The design of cross culverts shall be as follows:

- A.** Cross culverts shall be designed in accordance with procedures outlined in the U.S. Department of Transportation "Hydraulic Design of Highway Culverts," Hydraulic Design Series No. 5, latest revision.
- B.** Cross culvert size shall be determined based on runoff as specified in these standards.
- C.** Cross culverts shall be checked against 100-year runoff to assure that no adverse effect will occur upstream and downstream because of the higher design event.
- D.** Cross culvert profile will be determined by an examination of the overall profile of the channel for a minimum distance of 500-feet on each side of the installation.

#### **9-21 DRAINAGE ALONG CLASS "C" STREETS**

The criteria for design of drainage along Class "C" streets are as follows:

- A.** Roadside ditches shall be sized to convey anticipated runoff. If the roadside ditch extends beyond the dedicated right-of-way, either the right-of way shall be extended to contain the ditch in the right-of -way or a drainage easement shall be dedicated over the portion of the ditch outside the right-of-way.
- B.** Side slopes of roadside ditches shall be per Standard Drawing 4-8 of these Improvement Standards.
- C.** Hydraulic gradients for roadside ditches shall be shown on the plans and shall be below the structural section of the roadway. Ditches shall be designed to convey the 100-year design flow.
- D.** Driveway culverts sized for each individual lot shall be included in the plans.

<b>Standard Drawings</b>		
<b>Section 9 – Storm Drainage</b>		
<b>Drawing</b>	<b>Sheets</b>	<b>Description</b>
9-1	1	Pipe Bedding and Initial Backfill (Storm Drainage)
9-2	1 of 2	Standard Stormdrain Manhole
9-2	2 of 2	Standard Stormdrain Manhole Notes
9-3	1	Gray Cast Iron Standard 24” Manhole Frame & Cover
9-4	1	Gray Cast Iron Standard 36” Manhole Frame & Cover
9-5	1	Grate Type Manhole Cover
9-6	1 of 2	Grated Curb Inlet
9-6	2 of 2	Grated Curb Inlet
9-7	1	Pipe Connections
9-8	1 of 2	Lined Channel Section
9-8	2 of 2	Lined Channel Section
9-9	1	Typical Ramp and Transition Detail
9-10	1	Erosion Control Pipe Discharge
9-11	1	Erosion Control Ditch Discharge
9-12	1 of 2	Chain Link Fence
9-12	2 of 2	Chain Link Fence
9-13	1	Utility Stream Crossing
9-14	1	Flexible Connector Pipe to Manhole Detail
9-15	1 of 4	Detention Basin Outflow Structure Elevation
9-15	2 of 4	Detention Basin Outflow Structure Trash Screen Enclosure
9-15	3 of 4	Detention Basin Slide Gate Restrictor Outflow Control Structure
9-15	4 of 4	Detention Basin Shear Gate Restrictor Outflow Control Structure

INITIAL BEDDING AND BACKFILL  
CONFORMING TO THE COUNTY'S  
STANDARDS

BEDDING AND INITIAL  
BACKFILL MATERIAL. INSTALL  
AND MECHANICALLY COMPACT  
IN 6-INCH LAYERS.

ALTERNATE TRENCH

**PIPES 24" OR GREATER  
IN DIAMETER**

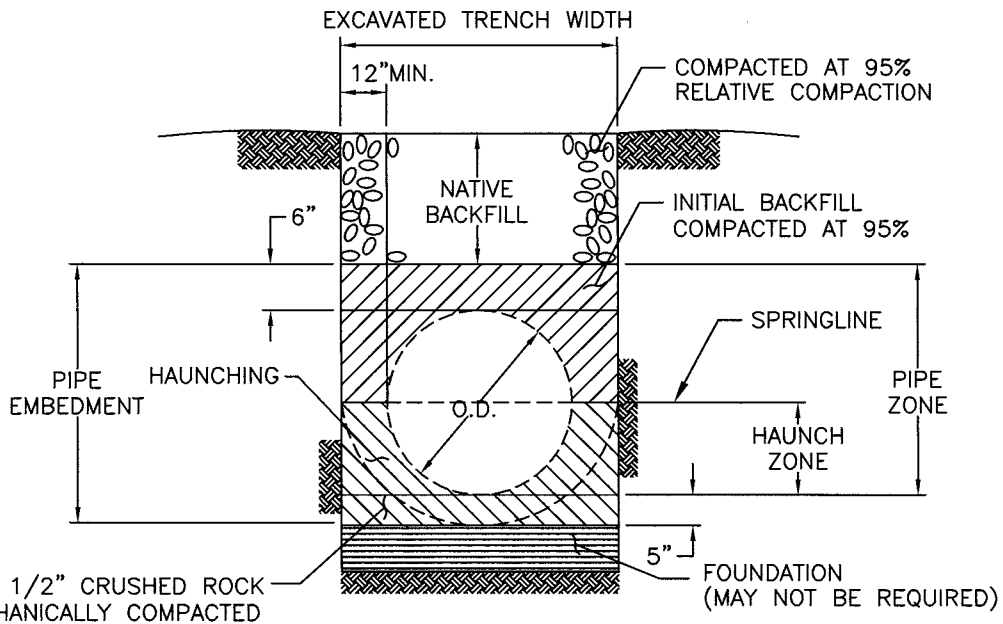
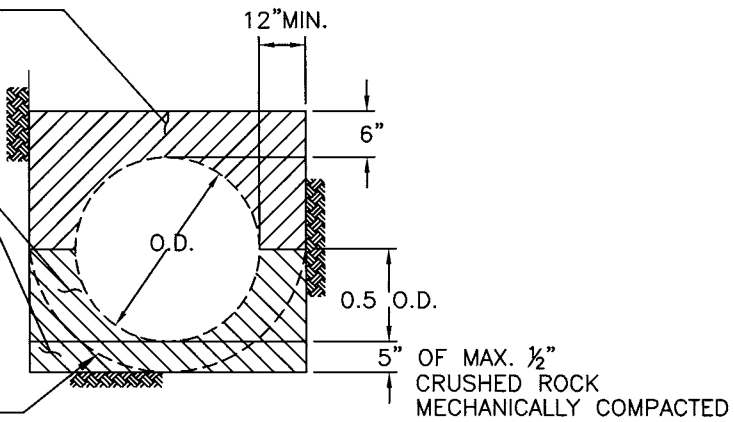

**PIPES LESS THAN 24"  
IN DIAMETER**

**NOTES:**

1. INITIAL BACKFILL MATERIAL SHALL BE THOROUGHLY COMPACTED AROUND PIPE.
2. TRENCH WIDTH SHALL CONFORM TO SECTION 9.
3. BEDDING AND INITIAL BACKFILL MATERIAL SHALL BE 1/2" CRUSHED ROCK, OR APPROVED EQUIVALENT.
4. REFER TO DRAWING 4-17 FOR TRENCH DETAILS IN IMPROVED AREAS.
5. HDPE PIPE, IF APPROVED BY COUNTY ENGINEER, SHALL BE BACKFILLED WITH 2-SACK LEAN CONCRETE BACKFILL MATERIAL.

<b>COUNTY OF YOLO</b> PLANNING AND PUBLIC WORKS DEPARTMENT		DATE: 08/05/08
<b>PIPE BEDDING AND INITIAL BACKFILL (STORM DRAINAGE)</b>		SHEET # 1 OF 1
<i>Parras Kakkas</i> COUNTY ENGINEER No. C42401		28 AUG 08 APPROVAL DATE
		DRAWING #: <b>9-1</b> NOT TO SCALE

IN PAVED AREAS SET COVER AND COLLAR 1/4" BELOW PAVEMENT, IN UNPAVED AREAS SET 1" ABOVE ADJACENT GRADE.

12" CONCRETE COLLAR W/2-#4 HOOPS IN UNPAVED AREAS

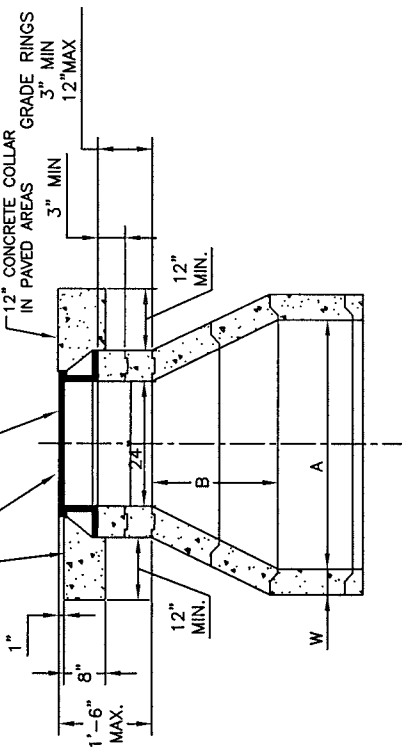

CONE TOP

IN PAVED AREAS SET COVER AND COLLAR 1/4" BELOW PAVEMENT, IN UNPAVED AREAS SET 1" ABOVE ADJACENT GRADE.

12" CONCRETE COLLAR W/2-#4 HOOPS IN UNPAVED AREAS

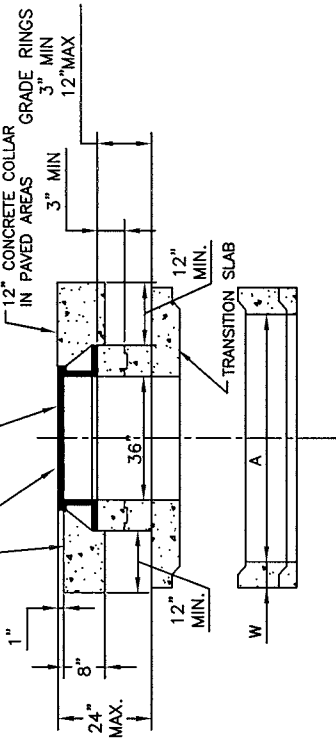

FLAT TOP SLAB

PRECAST REINFORCED MANHOLE SECTIONS (REBAR NOT SHOWN)

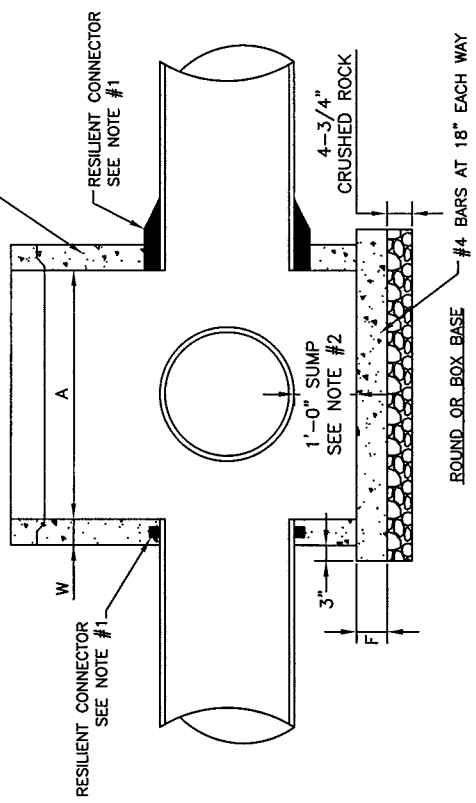

ROUND OR BOX BASE #4 BARS AT 18" EACH WAY

TABLE OF MINIMUM DIMENSIONS FOR ROUND MANHOLES

M.H	A	B	W	F
48"	48"	18"	5"	7" MIN.
60"	60"	30"	6"	9" MIN.

PIPE OPENINGS PER PLAN AS REQ'D.

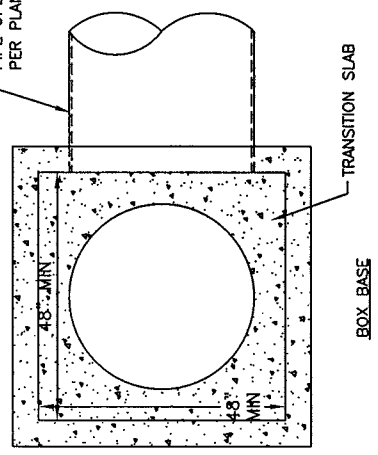

BOX BASE

COUNTY OF YOLO  
PLANNING AND PUBLIC WORKS DEPARTMENT

DATE: 08/05/08  
SHEET # 1 OF 2

STANDARD STORMDRAIN MANHOLE

*Panos*  
COUNTY ENGINEER No. C42401  
APPROVAL DATE 28 AUG. 08  
DRAWING #: 9-2  
NOT TO SCALE



NOTES:

1. ON ALL PIPE UP TO 30" I.D., USE FLEXIBLE COMPRESSION GASKET OR BOOT CONNECTOR CONFORMING TO ASTM C-923. CONNECTION SHALL BE WATER AND SOIL TIGHT. FOR PIPES GREATER THAN 30" I.D., BASE MAY BE CAST-IN-PLACE AND A WATER STOP CONFORMING TO ASTM C-923 SHALL BE USED.
2. SUMP SHALL BE 1'-0" DEEP, MEASURED FROM INVERT OF OUTFALL PIPE. SUMP NOT REQUIRED IF OUTFALL IS 24" I.D. OR LARGER. SUMPS SHALL NOT BE ALLOWED OUT OF THE COUNTY RIGHT OF WAY.
3. RISER SECTIONS, CONES, AND ADJUSTING RINGS SHALL CONFORM TO ASTM C-478.
4. ALL JOINTS SHALL BE MADE WITH PREFORMED PLASTIC JOINT SEALING COMPOUND OR PRE-LUBRICATED GASKET. FOLLOWING INSTALLATION GROUT ALL INTERIOR AND EXTERIOR JOINTS.
5. CONCENTRIC COMPONENTS SHALL BE USED UNLESS OTHERWISE SPECIFIED ON THE PLANS.
6. PRECAST MANHOLES SHALL BE SIZED TO PROVIDE THE FOLLOWING: THE ANNULAR SPACE ON THE INSIDE OF THE MANHOLE BARREL BETWEEN THE CORED PIPE CONNECTION HOLES SHALL BE A MINIMUM OF 10-INCHES. IF THE CONNECTION HOLE IS CAST MONOLITHICALLY WITH THE MANHOLE BARREL THE MEASUREMENT SHALL BE TAKEN FROM THE FINISHED CONCRETE CONNECTION SURFACE.
7. CONSTRUCT WITH FLAT SLAB-TOP WHEN HEIGHT IS TOO SHALLOW TO CONSTRUCT WITH CONES.
8. FOR THE SLAB REDUCER OF THE BOX MANHOLE (BOX TO ROUND DIAMETER), THE DIAMETER OF THE ROUND REDUCER SHALL BE A MAX OF 12" SMALLER THAN THE INSIDE BOX WIDTH.
9. FLAT SLAB TOP MANHOLES SHALL HAVE A 36" MANHOLE FRAME AND COVER.

<b>COUNTY OF YOLO</b> PLANNING AND PUBLIC WORKS DEPARTMENT		DATE: 08/05/08
STANDARD STORMDRAIN MANHOLE		SHEET # 2 OF 2
<i>Paros Kokkas</i> COUNTY ENGINEER No. C42401	<i>28 AUG-08</i> APPROVAL DATE	DRAWING #: 9-2 NOT TO SCALE

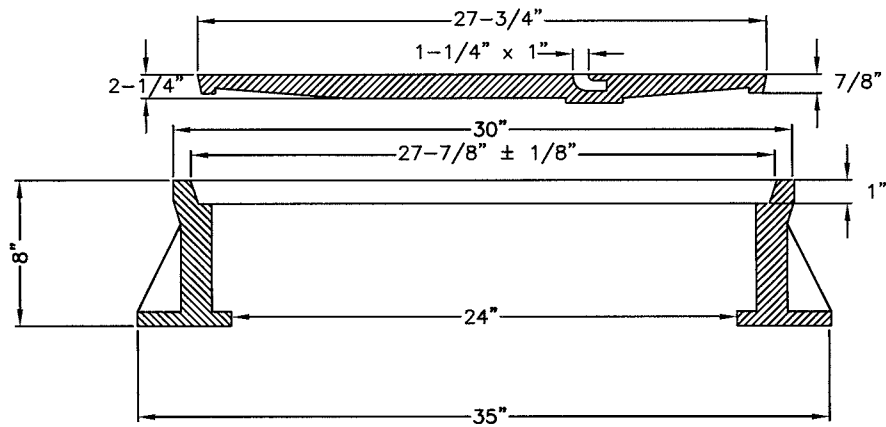
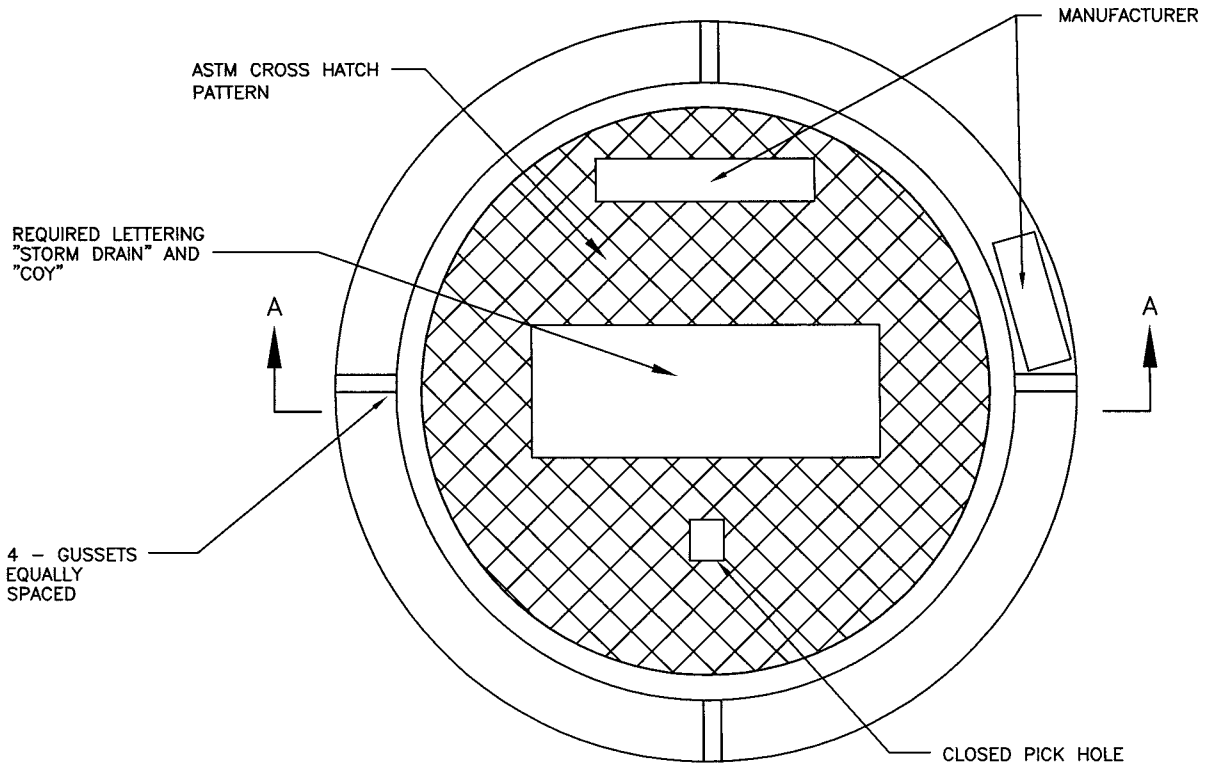

SECTION A-A

**NOTES:**

1. ALL CASTINGS TO CONFORM TO ASTM A48, CLASS 35B. D&L FOUNDRY A-1018, OR EQUIVALENT
2. FRAME AND COVER TO MEET H-20 LOAD SPECIFICATIONS.
3. MACHINED HORIZONTAL AND VERTICAL BEARING SURFACES NOT TO EXCEED 1/64" TOLERANCE.
4. FRAME AND COVER SHALL HAVE A COATING OF BITUMINOUS MATERIAL.
5. LOCKING COVER TYPE FRAME AND COVERS SHALL BE USED IN EASEMENT AREAS UNLESS OTHERWISE APPROVED.
6. COVER SHALL BE LABELED AS REQUIRED BY SERVICE DISTRICT. COUNTY COVERS SHALL BE DENOTED "COY".

<b>COUNTY OF YOLO</b> PLANNING AND PUBLIC WORKS DEPARTMENT		DATE: 08/05/08
<b>GRAY CAST IRON STANDARD</b> <b>24" MANHOLE FRAME AND COVER</b>		SHEET # 1 OF 1
<i>Panos Korkkas</i> COUNTY ENGINEER No. C42401		28 AUG 08 APPROVAL DATE
		DRAWING #: <b>9-3</b> NOT TO SCALE

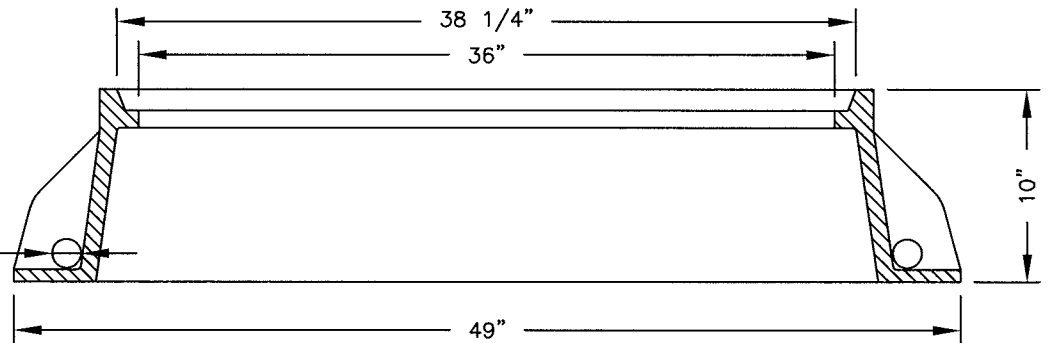
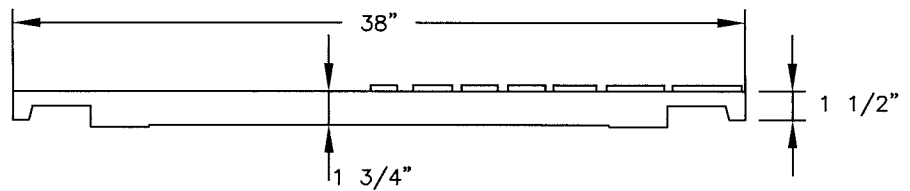
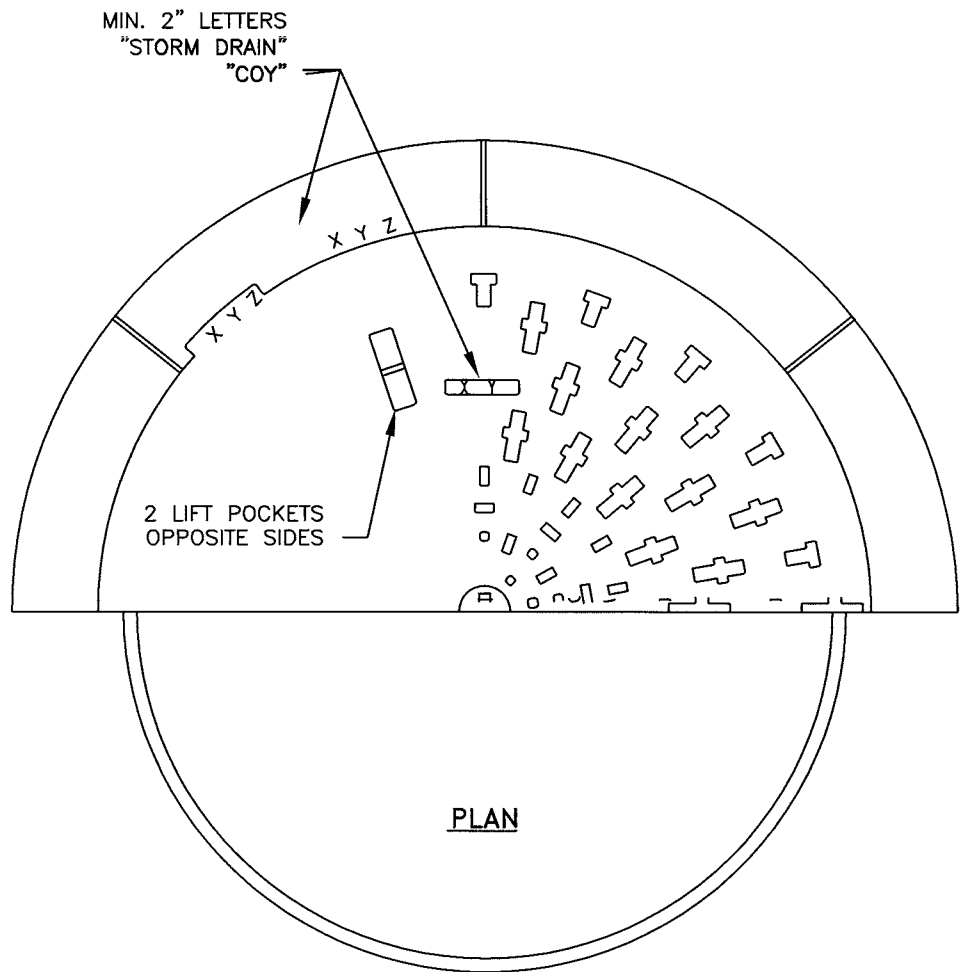

**NOTES:**

1. ALL CASTING TO CONFORM TO ASTM A48, CLASS 35B. D&L FOUNDRY A-1382, OR EQUIVALENT.
2. FRAME AND COVER TO MEET H-20 LOAD SPECIFICATIONS.
3. MACHINED HORIZONTAL AND VERTICAL BEARING SURFACES NOT TO EXCEED 1/64" TOLERANCE.
4. FRAME AND COVER SHALL HAVE A COATING OF BLACK BITUMINOUS PAINT.
5. LOCKING COVER TYPE FRAME AND COVERS SHALL BE USED IN EASEMENT AREAS UNLESS OTHERWISE APPROVED.

<b>COUNTY OF YOLO</b> PLANNING AND PUBLIC WORKS DEPARTMENT		DATE: 08/05/08
<b>GRAY CAST IRON STANDARD 36"</b> <b>MANHOLE FRAME AND COVER</b>		SHEET # 1 OF 1
<i>Parras Koffas</i> COUNTY ENGINEER No. C42401		DRAWING #: <b>9-4</b> NOT TO SCALE
28 AUG-08 APPROVAL DATE		

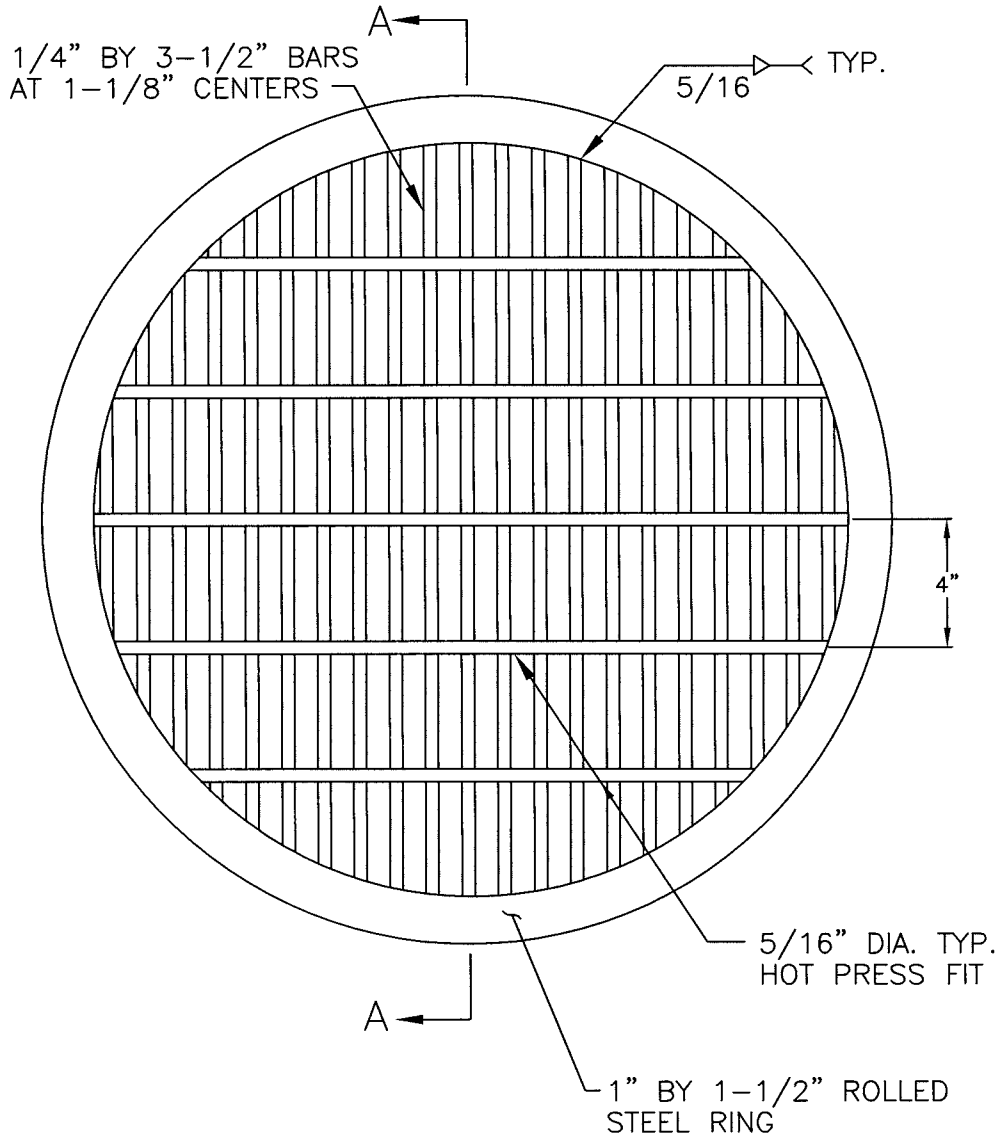

**NOTES:**

1. MANHOLE COVER SHALL FIT FRAME SHOWN ON DRAWING 9-2.
2. SEATING SURFACES SHALL BE MACHINED AS SHOWN IN DETAIL ON DRAWING 9-2.
3. THIS COVER MAY BE USED ONLY WITH APPROVAL OF THE COUNTY ENGINEER.
4. GALVANIZE AFTER FABRICATION PER ASTM 123.
5. PROVIDE BICYCLE PROOF AND ADA COMPLIANT GRATE.

<b>COUNTY OF YOLO</b> PLANNING AND PUBLIC WORKS DEPARTMENT		DATE: 08/05/08
GRATE TYPE MANHOLE COVER		SHEET # 1 OF 1
<i>Parras Kakkas</i> COUNTY ENGINEER No. C42401	28 AUG. 08 APPROVAL DATE	DRAWING #: <b>9-5</b> NOT TO SCALE

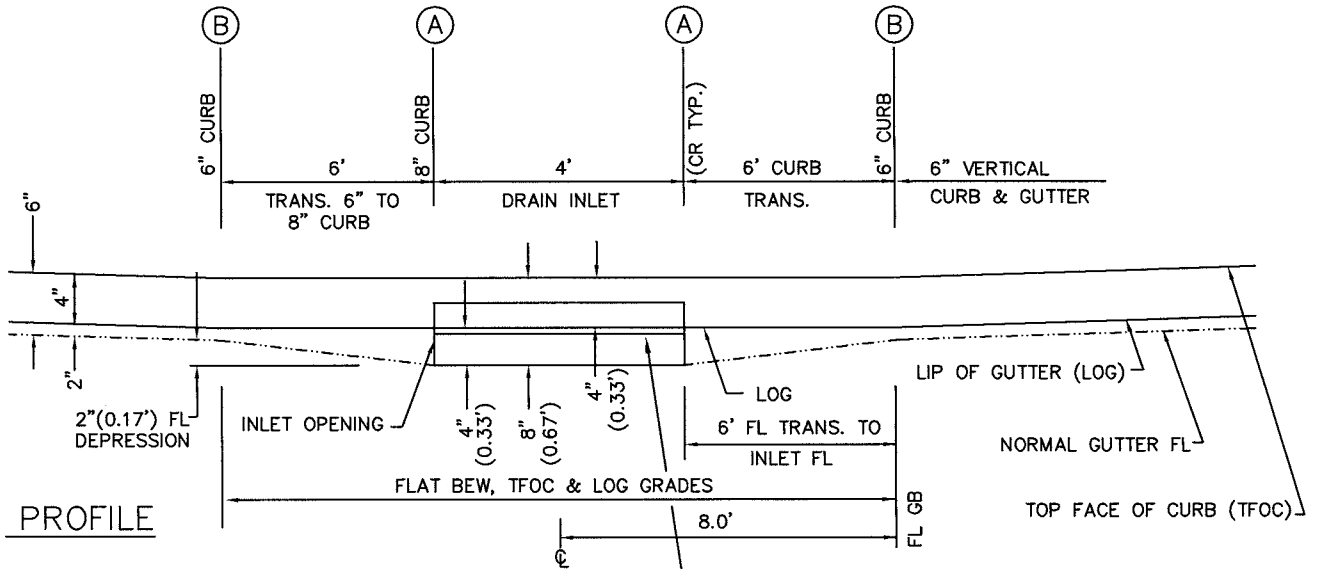
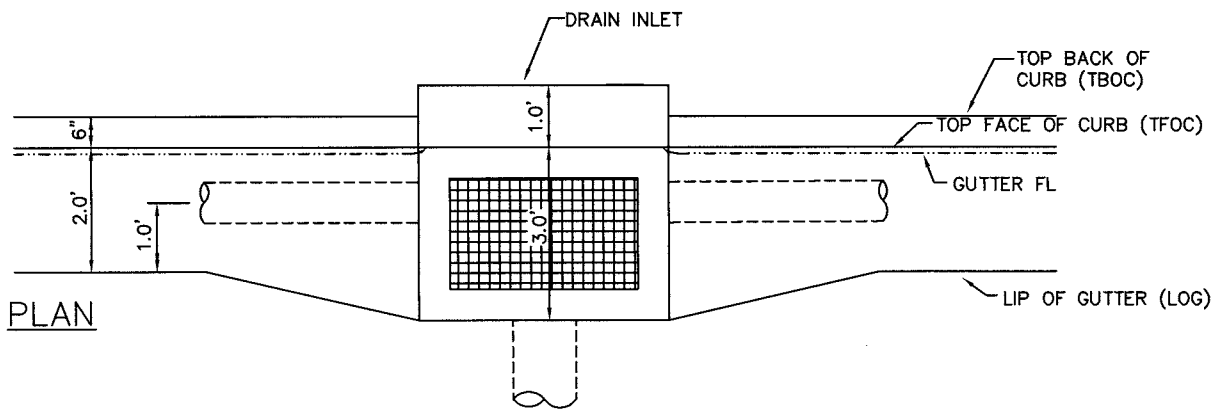

	(A)	(B)
FL TO LOG	0.33'	0.17'
FL TO TFOC	0.67'	0.50'

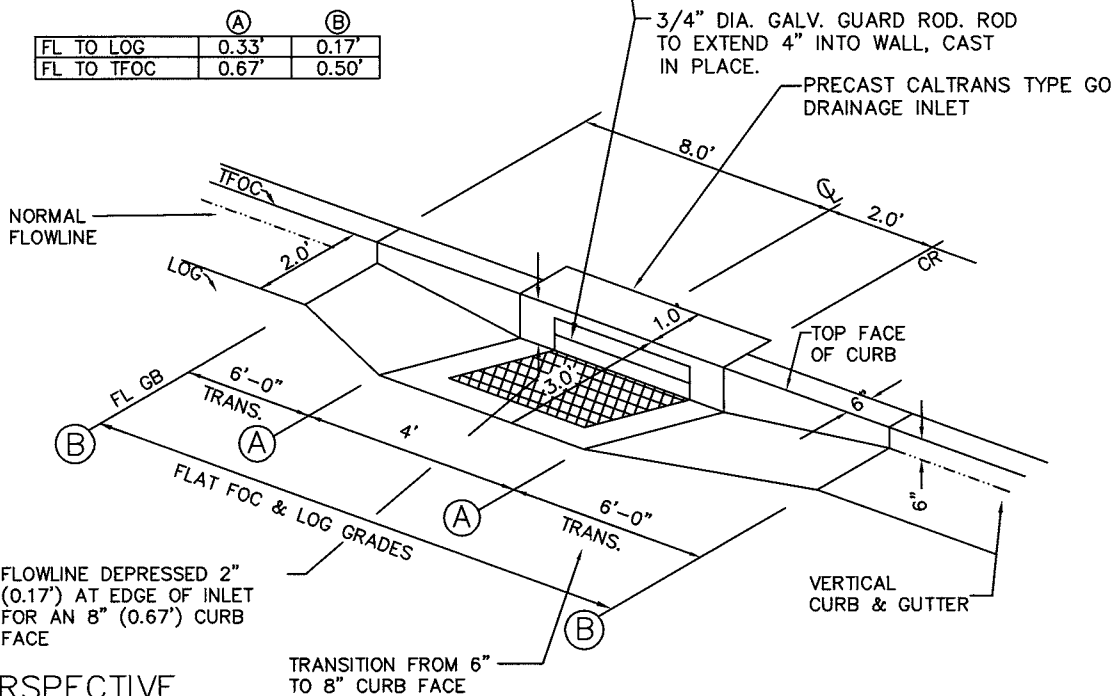

**NOTE:**  
 1. PROVIDE NPDES LOGO IN TOP OF CURB. "NO DUMPING DRAINS TO WATERWAY".

<b>COUNTY OF YOLO</b> PLANNING AND PUBLIC WORKS DEPARTMENT		DATE: 08/05/08
<b>GRATED CURB INLET</b>		SHEET # 1 OF 2
<i>Panos Kofkas</i> COUNTY ENGINEER No. C42401		DRAWING #: <b>9-6</b> NOT TO SCALE
28 AUG. 08 APPROVAL DATE		

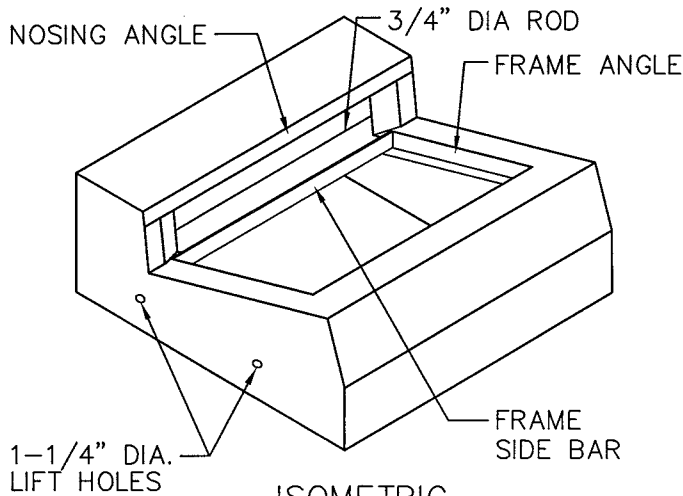

ISOMETRIC

PRECAST GO TOP

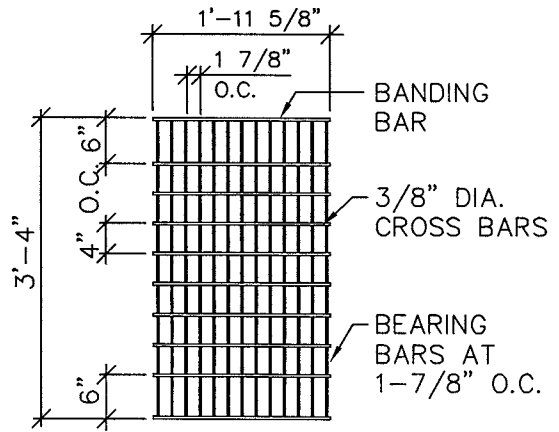

GRATE PLAN

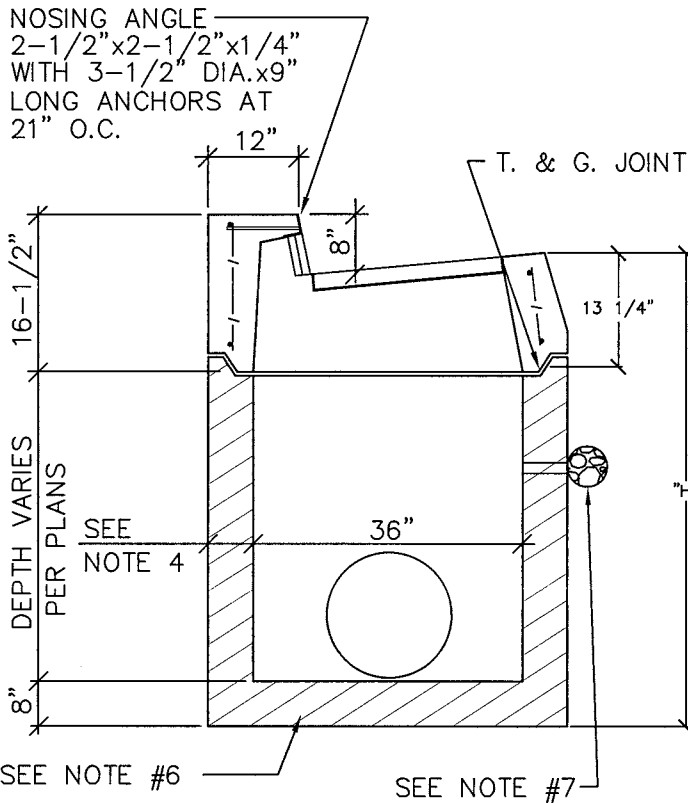

SECTION

GRATE (24-13)
13 BEARING BARS, 3-1/2"x1/4"
2 BANDING BARS, 2-1/2"x1/4"
FRAME
4"x3"x1/4" ANGLES
3-1/2"x1/4" SIDE BARS

- NOTES:
1. CONCRETE SHALL TEST TO 3000 PSI AT 28 DAYS.
  2. FRAME, GRATE AND NOSING ANGLE SHALL BE HOT DIP GALVANIZED. AFTER FABRICATION PER ASTM SPEC. A-123, UNLESS SPEC'D OTHERWISE.
  3. WEIGHT OF PRECAST TOP WITHOUT GRATE = 1350 LBS. WEIGHT OF GRATE = 141 LBS.
  4. WHERE "H" IS 8'-0" OR LESS THE WALL THICKNESS SHALL BE 6". WHERE "H" IS GREATER THAN 8'-0" THE WALL THICKNESS SHALL BE 8".
  5. REINFORCING OF PRECAST BASE SHALL BE PER CALTRANS STANDARD PLAN D-74B.
  6. SET PRECAST INLET ON 6" LAYER OF MECHANICALLY COMPACTED 3/4" CRUSHED ROCK COMPACTED TO 95% OVER 8" SUBGRADE COMPACTED TO 95%.
  7. PROVIDE THREE 2" DIAMETER SUBSURFACE DRAINS IN FACE OF INLET LOCATED 2" ABOVE STREET SUBGRADE. PROVIDE 1 CUBIC FOOT OF DRAIN ROCK ENCLOSED IN 12oz GEOTEXTILE WRAP AT EACH HOLE.

<b>COUNTY OF YOLO</b> PLANNING AND PUBLIC WORKS DEPARTMENT		DATE: 08/05/08
DROP INLET TYPE "GO" VERTICAL CURB AND GUTTER ONLY		SHEET # 2 OF 2
<i>Panos Kakkas</i> COUNTY ENGINEER No. C42401		DRAWING #: 9-6 NOT TO SCALE
<i>28 AUG. 08</i> APPROVAL DATE		

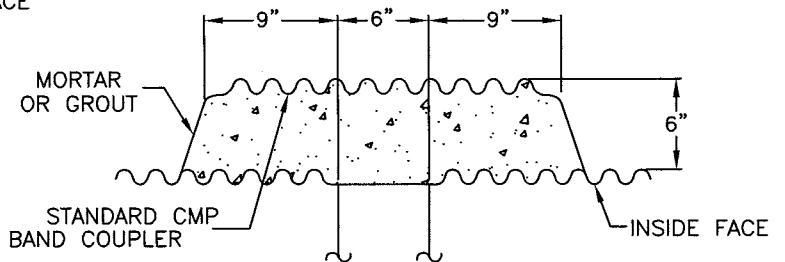
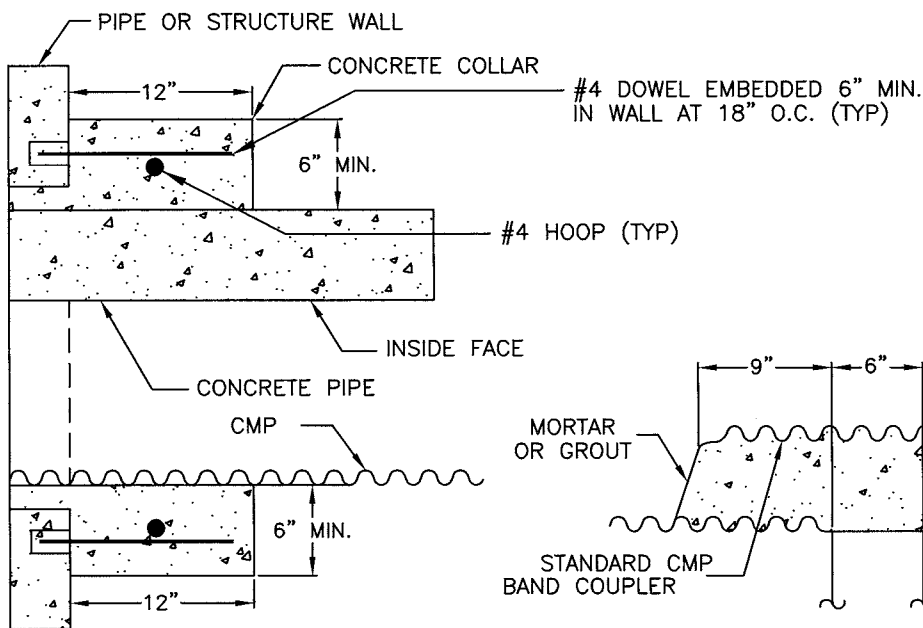
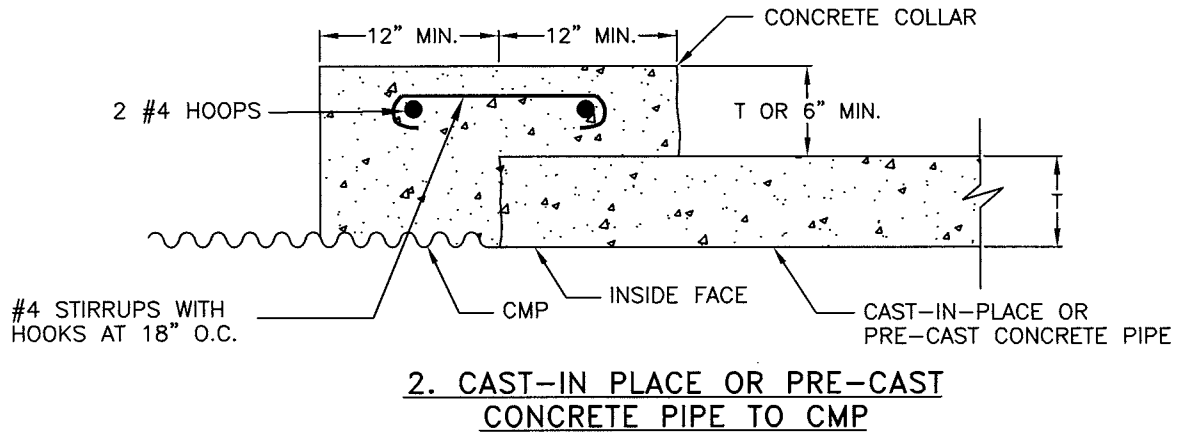
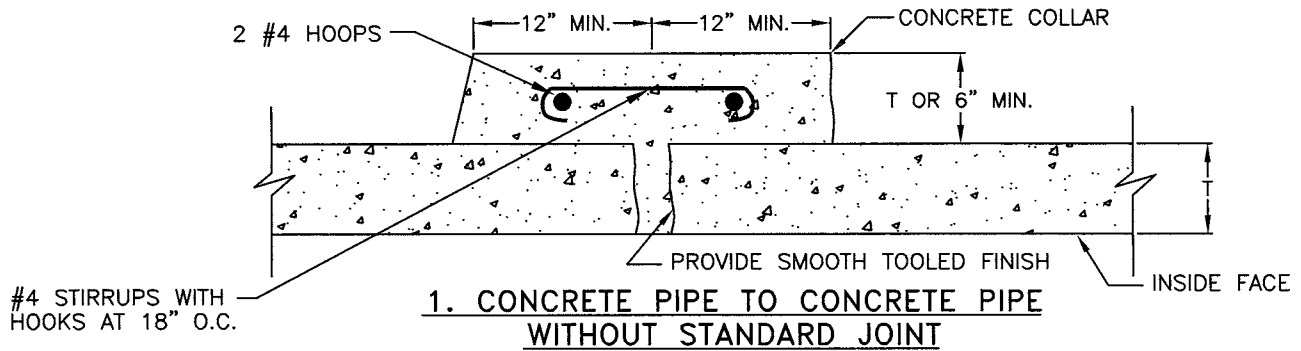

**3. CONCRETE PIPE, CMP INTO EXISTING PIPE OR STRUCTURE**

**4. PIPES OF DISSIMILAR METALS**

**NOTES:**

1. PIPE CONNECTIONS SHOWN ON THIS PAGE MAY BE USED ONLY WHEN APPROVED BY THE COUNTY ENGINEER.

2. USE MANUFACTURERS STANDARD COUPLINGS WHERE POSSIBLE.

<b>COUNTY OF YOLO</b> PLANNING AND PUBLIC WORKS DEPARTMENT		DATE: 08/05/08
<b>PIPE CONNECTIONS</b>		SHEET # 1 OF 1
<i>Panos Kokkas</i> COUNTY ENGINEER No. C42401		28 AUG. 08 APPROVAL DATE
		DRAWING #: 9-7 NOT TO SCALE

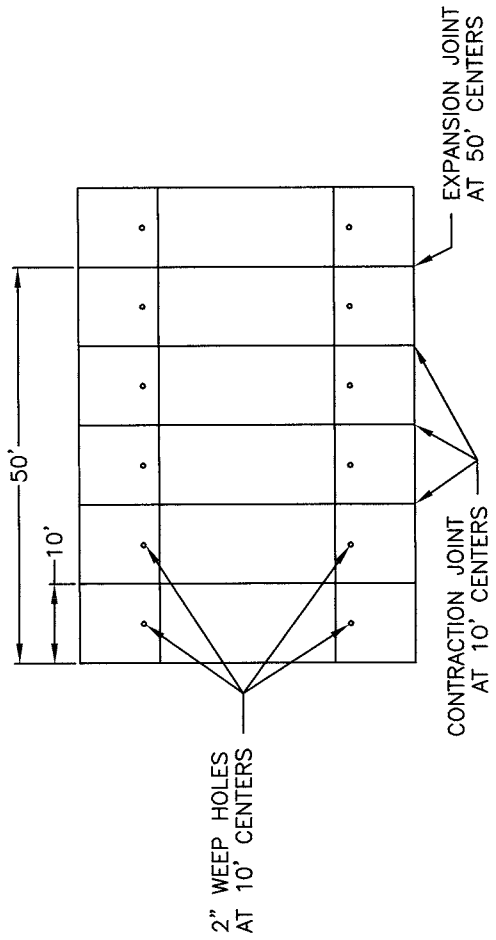

PLAN VIEW

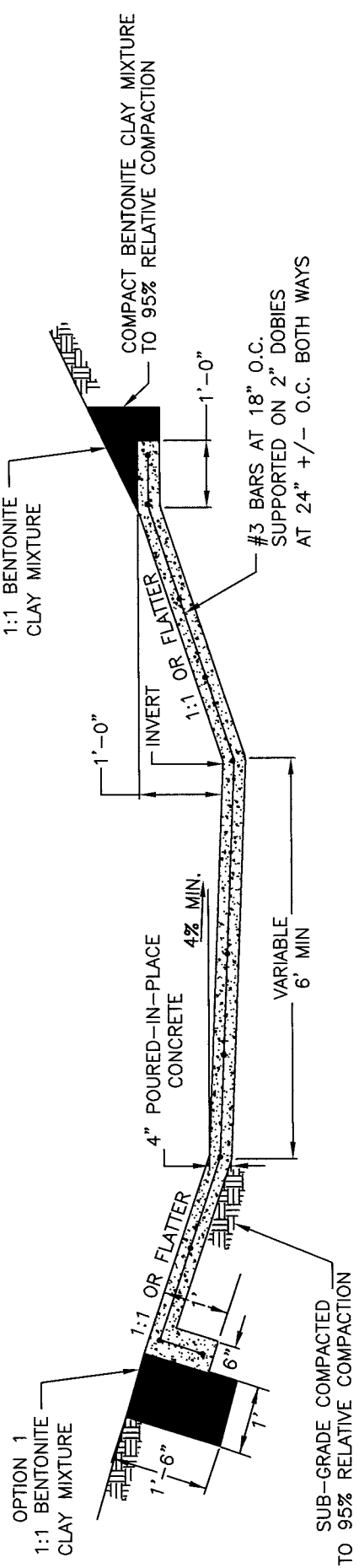

TYPICAL BOTTOM LINING

COUNTY OF YOLO PLANNING AND PUBLIC WORKS DEPARTMENT	DATE: 08/05/08
LINED CHANNEL SECTION	SHEET # 1 OF 2
<i>Parsons</i> COUNTY ENGINEER No. C42401	DRAWING #: 9-8 NOT TO SCALE
<i>28 Aug. 08</i> APPROVAL DATE	



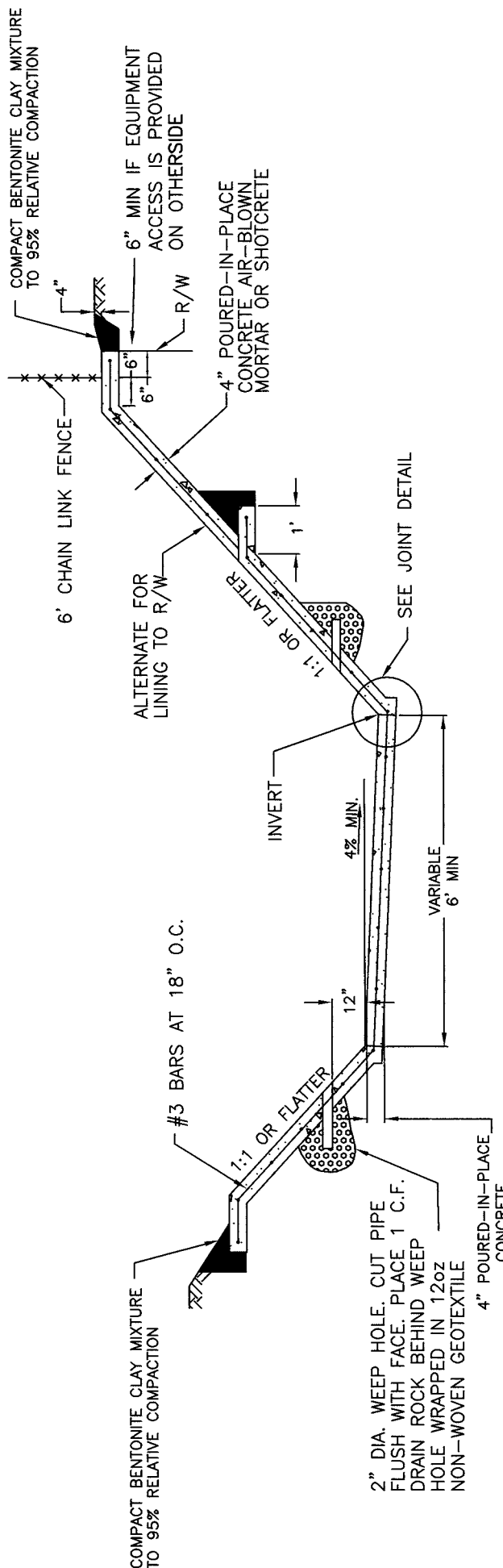

TYPICAL FULL LINING

#3 BARS AT 18" O.C.

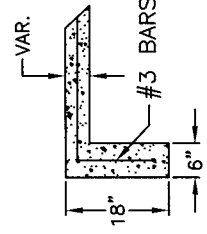

CUTOFF WALL

TO BE PLACED ALONG ENTIRE END OF LINED SECTION AT BEGINNING AND AT END OF LINING

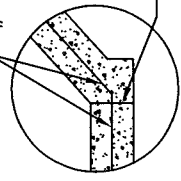

JOINT DETAIL

ALL REBAR SHALL BE SUPPORTED ON 2" DOBIES AT 24" +/- O.C. BOTH WAYS

COUNTY OF YOLO PLANNING AND PUBLIC WORKS DEPARTMENT	DATE: 08/05/08
LINED CHANNEL SECTION	SHEET # 2 OF 2
<i>Panos Koblas</i> COUNTY ENGINEER No. C42401	DRAWING #: 9-8 NOT TO SCALE
APPROVAL DATE 28 AUG 08	

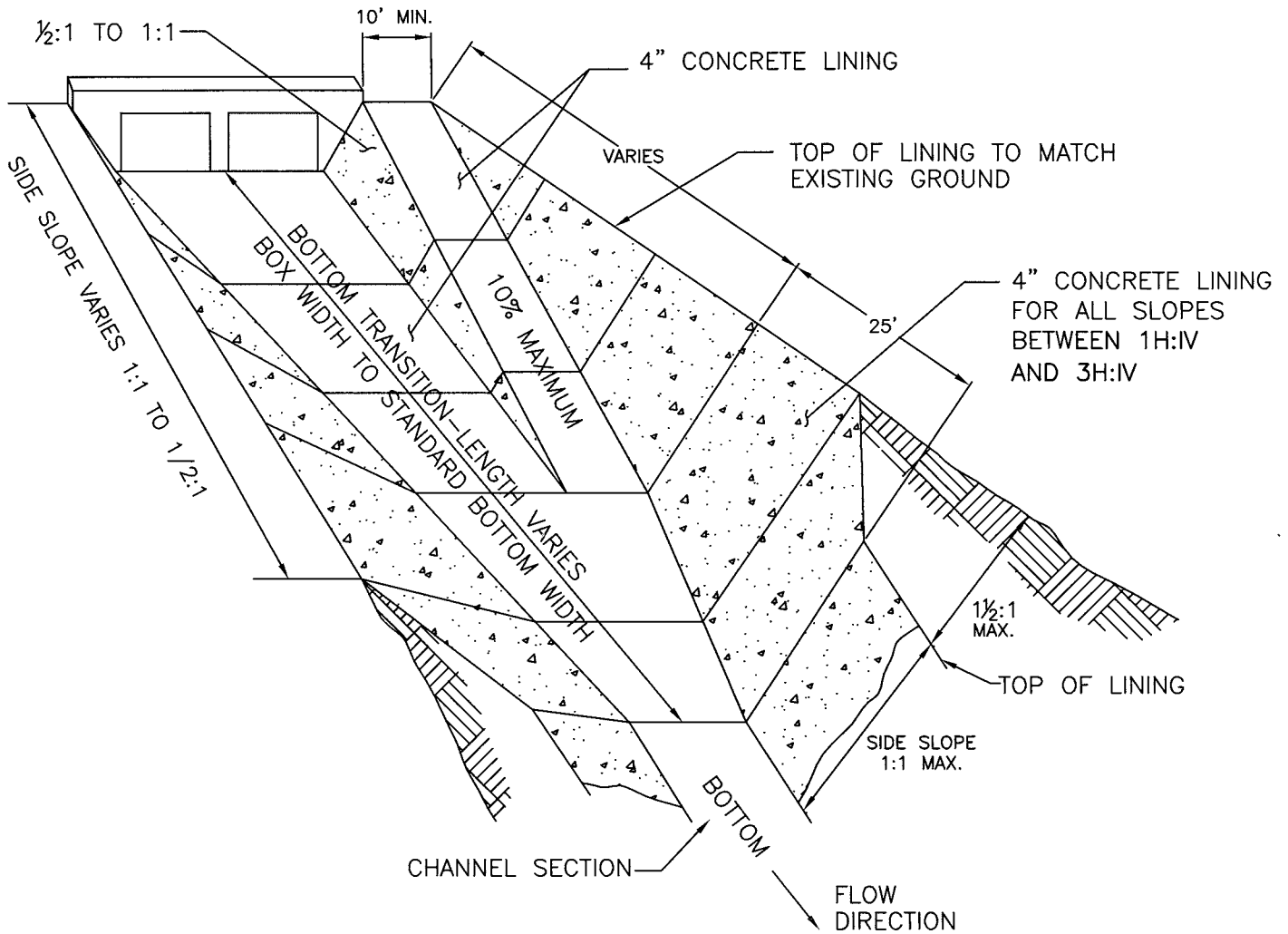

**NOTES:**

1. BOTTOM TRANSITION IS 25' MINIMUM LENGTH WITH NO RAMP.
2. WEEP HOLES AND JOINTS AS REQUIRED FOR ALL LINED CHANNEL SECTIONS.
3. LOW SIDE OF CHANNEL TO BE OPPOSITE RAMP.

<b>COUNTY OF YOLO</b> PLANNING AND PUBLIC WORKS DEPARTMENT		DATE: 08/05/08
TYPICAL RAMP AND TRANSITION DETAIL		SHEET # 1 OF 1
<i>Panos Kokkas</i> COUNTY ENGINEER No. C42401	28 AUG. 08 APPROVAL DATE	DRAWING #: 9-9 NOT TO SCALE

H=6'-0" MINIMUM  
H=2X PIPE DIA. (3' TO 6')

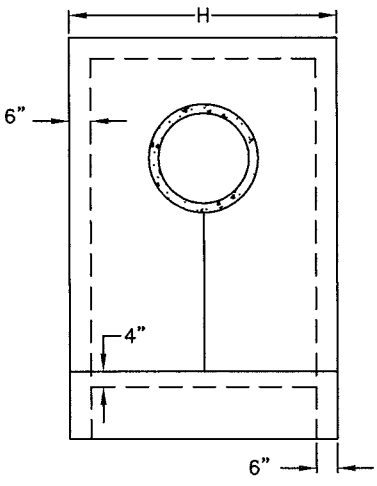

FRONT VIEW

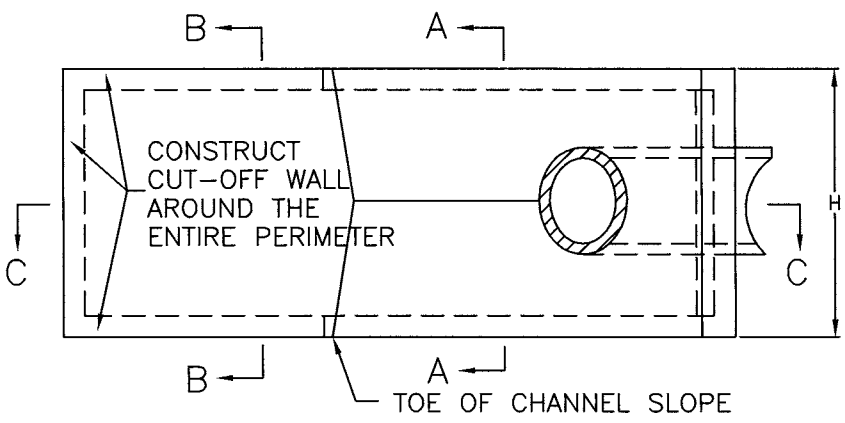

TOP VIEW

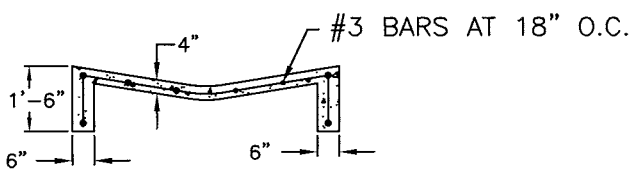

SECTION A-A

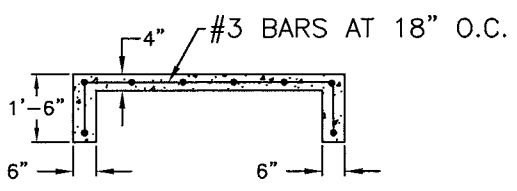

SECTION B-B

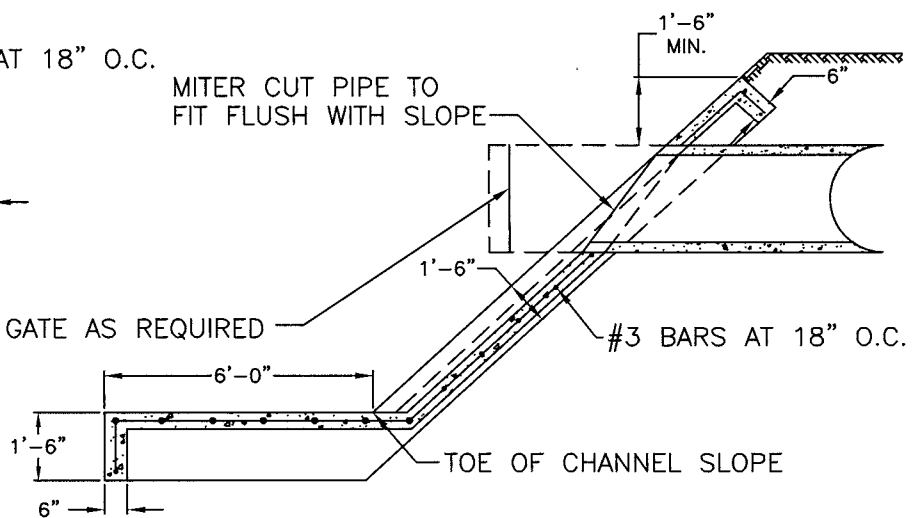

SECTION C-C

**NOTES:**

1. USE CLASS "B" CONCRETE OR GROUTED COBBLES AS SPECIFIED.
2. #3 BARS AT 18" CENTERS THROUGHOUT CONCRETE SUPPORTED ON 2" DOBIES AT 24" +/- O.C. BOTH WAYS.

<b>COUNTY OF YOLO</b> PLANNING AND PUBLIC WORKS DEPARTMENT		DATE: 08/05/08
EROSION CONTROL PIPE DISCHARGE		SHEET # 1 OF 1
<i>Parras Koffas</i> COUNTY ENGINEER No. C42401	28 AUG. 08 APPROVAL DATE	DRAWING #: 9-10 NOT TO SCALE

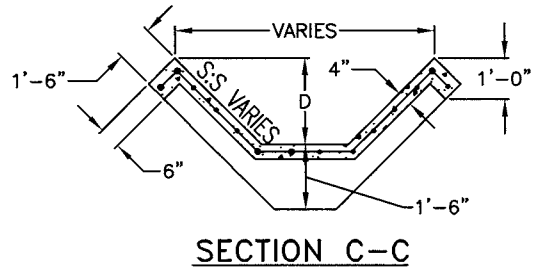
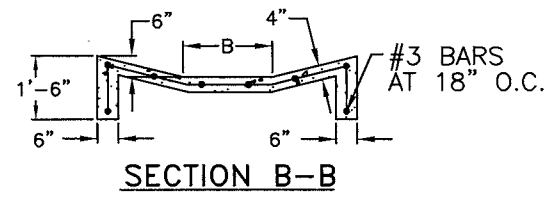
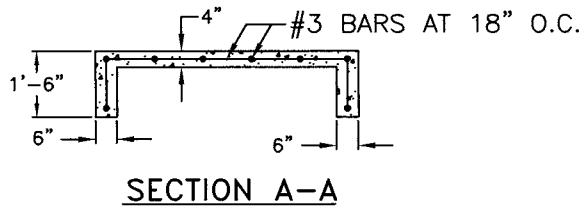
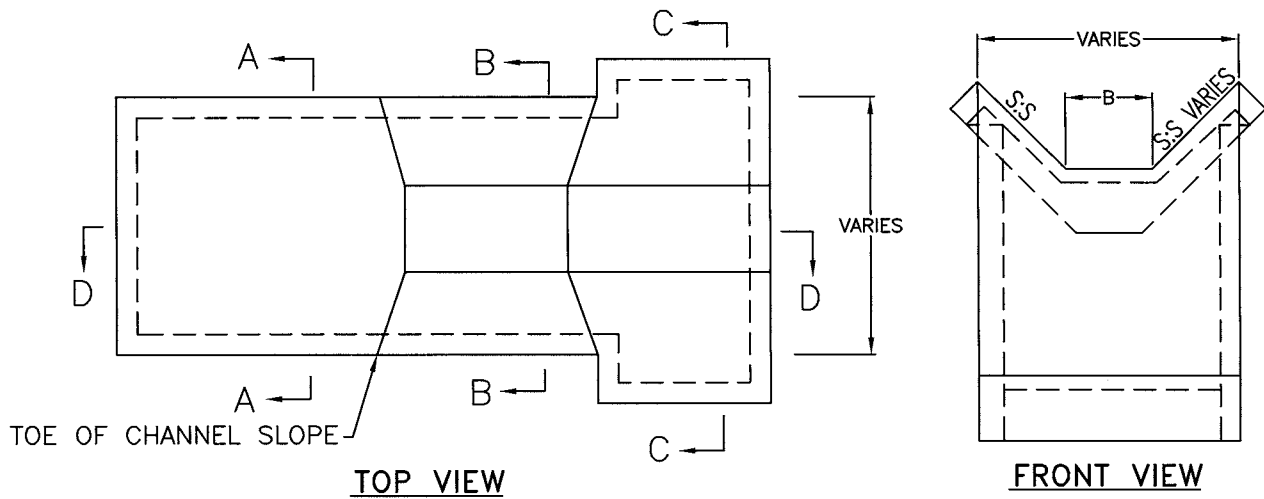

**NOTES:**

1. USE CLASS "B" CONCRETE.
2. #3 BARS AT 18" CENTERS THROUGHOUT CONCRETE SUPPORTED ON 2" DOBIES AT 24" +/- O.C. BOTH WAYS.
3. ON LINED CHANNELS APRON SHALL CONNECT TO SIDE LINING.
4. B=DITCH BOTTOM WIDTH OR AS SHOWN ON PLANS.
5. D=DITCH WATER DEPTH PLUS ONE FOOT OF FREEBOARD.

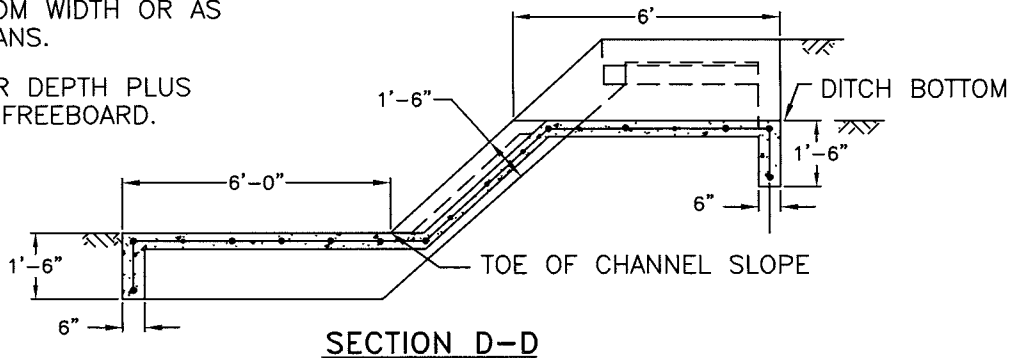

<b>COUNTY OF YOLO</b> PLANNING AND PUBLIC WORKS DEPARTMENT		DATE: 08/05/08
<b>EROSION CONTROL</b> <b>DITCH DISCHARGE</b>		SHEET # 1 OF 1
<i>Panos Kappas</i> COUNTY ENGINEER No. C42401	28 AUG. 08 APPROVAL DATE	DRAWING #: <b>9-11</b> NOT TO SCALE

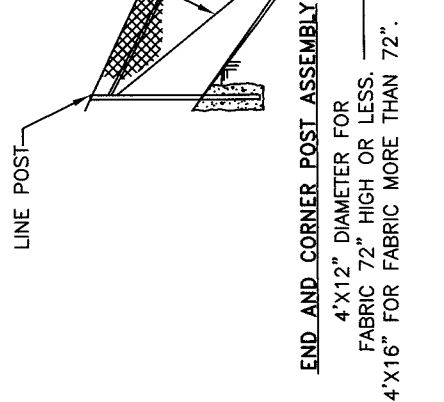
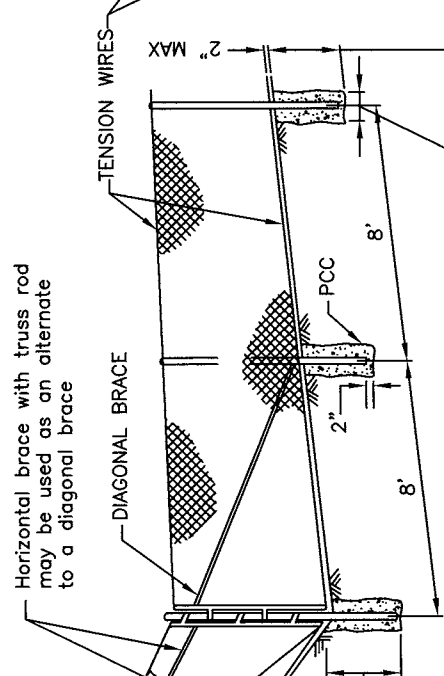
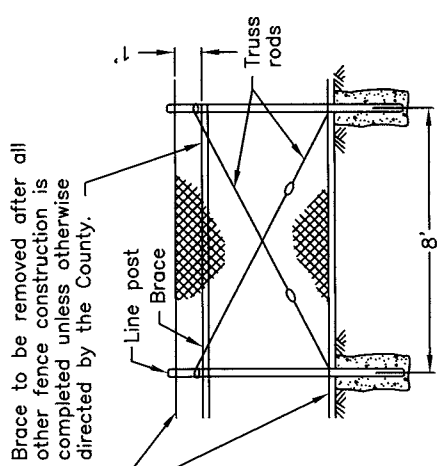
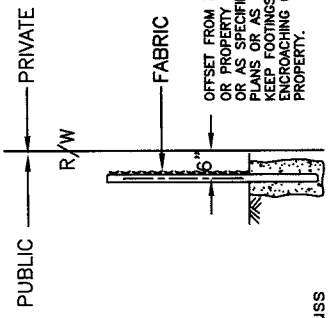

Line posts at 1000' maximum intervals braced and trussed in both directions except that this bracing and trussing may be omitted when the fabric is stretched by the equipment.

LINE POSTS:  
 4' X 12" DIAMETER FOR FABRIC 72" HIGH OR LESS.  
 4' X 16" FOR FABRIC GREATER THAN 72".

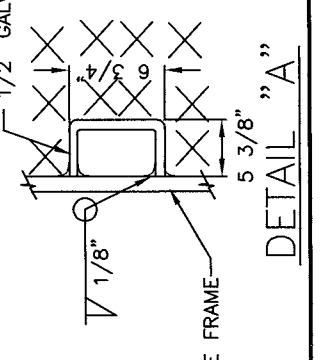
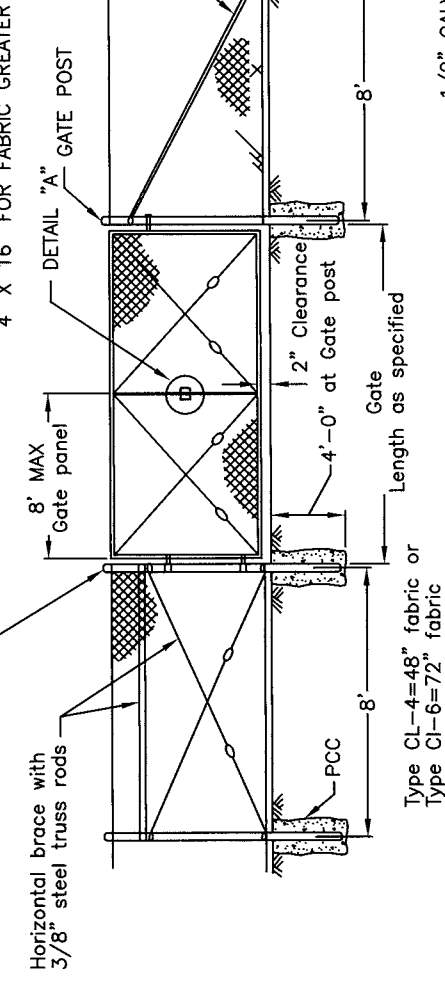

Type CL-4=48" fabric or  
 Type CI-6=72" fabric

- NOTES:**
- Chain link fabric shall be zinc coated steel manufactured in compliance with ASTM Standard A 392 with a 2 inch mesh of 9 gauge wire with knuckled selvage.
  - Tension wire shall be 7 gauge.
  - Where barbed wire is specified, it shall include 3 strands of galvanized 4 point wire attached with extension arms set at 45 degrees.
  - In residential areas, fabric shall be vinyl coated with slats, color determined by Director.
  - Increase diameter of concrete footing to 16" diameter for 8' chain link fencing.

**COUNTY OF YOLO**  
 PLANNING AND PUBLIC WORKS DEPARTMENT

**CHAIN LINK FENCE**

DATE: 08/05/08  
 SHEET # 1 OF 2  
 DRAWING #: 9-12  
 NOT TO SCALE

APPROVAL DATE: 28 AUG 08  
 COUNTY ENGINEER No. C42401

TYPICAL MEMBER DIMENSIONS (SEE NOTES BELOW)

FENCE HEIGHT	LINE POSTS		END, LATCH AND CORNER POSTS		RAILS AND BRACES			
	NOMINAL ROUND O.D. (NOTES 7 AND 8)	H	ROLL FORMED	NOMINAL ROUND O.D. (NOTES 7 AND 8)	ROLL FORMED	H	NOMINAL ROUND O.D. (NOTES 7 AND 8)	ROLL FORMED
Less than 6'	1-1/2"	1-7/8"x1-5/8"	3-1/2" x 3-1/2"	2-1/2"	2" x 1-3/4"	1-1/2" x 1-5/16"	1-1/4"	1-5/8" x 1-1/4"
6'	2"	2-1/4" x 2"	3-1/2" x 3-1/2"	2-1/2"	2" x 1-3/4"	1-1/2" x 1-5/16"	1-1/4"	1-5/8" x 1-1/4"

GATE POST (NOTE 7)

FENCE HEIGHT	GATE WIDTHS	NOMINAL O.D.	WEIGHT PER FOOT
Less than 6'	Up thru 6'	2-1/2"	5.79
	Over 6' thru 12'	4"	10.79
	Over 12' thru 18'	5"	14.62
6'	Over 18' to 24' max	6"	18.97
	Up thru 6'	3"	7.58
	Over 6' thru 12'	5"	14.62
	Over 12' thru 18'	6"	18.97
	Over 18' to 24' max	8"	28.55

**NOTES:**

- The above table shows examples of post and brace sections which may comply with the Standard Construction Specifications.
- Sections shown in the tables must also comply with the strength requirements and other provisions of the Standard Construction Specifications.
- Other sections which comply with the strength requirements and other provisions of the Standard Construction Specifications may be used on approval of the Engineer.
- Options exercised shall be uniform on any one project.
- Dimensions shown are nominal.
- Offset to be 2'-0" at monument locations, measured at right angles to R/W lines. Taper to achieve offset to be at least 20' long.
- Pipe sections for posts, rails, braces, and gates shall be schedule 40 galvanized pipe manufactured in conformance with ASTM F 1083.
- Weight per foot values for 1-5/8" O.D. pipe = 2.27 lbs/ft, 2-3/8" O.D. pipe = 3.65 lbs/ft, 2-7/8" O.D. pipe = 5.79 lbs/ft.
- Chain link gate frames shall be a minimum of 1-7/8" pipe weighing 2.72 lbs/ft.
- Galvanized gate holders of heavy cast construction with counterbalanced latches shall be provided for all gates. Gate holders shall be anchored with a minimum 24" length of 1-5/8" schedule 40 pipe set in 8" diameter concrete base.

Above post dimensions and masses are minimums. Larger sizes may be used on approval of the County Engineer.

COUNTY OF YOLO PLANNING AND PUBLIC WORKS DEPARTMENT	DATE: 08/05/08
CHAIN LINK FENCE	SHEET # 2 OF 2
<i>Panos Kokkas</i> COUNTY ENGINEER No. C42401	DRAWING #: 9-12 NOT TO SCALE
<i>28 Aug. 08</i> APPROVAL DATE	

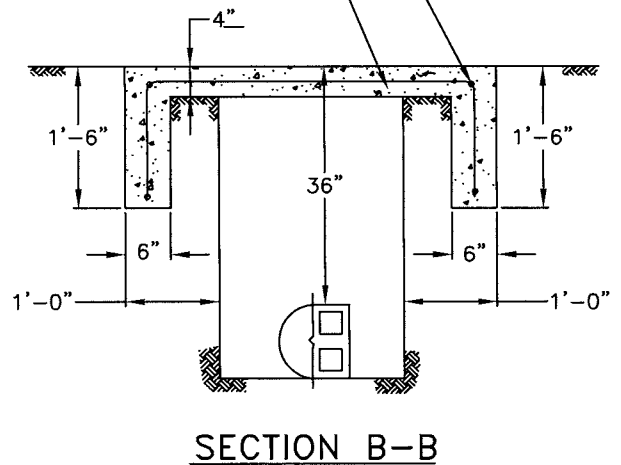
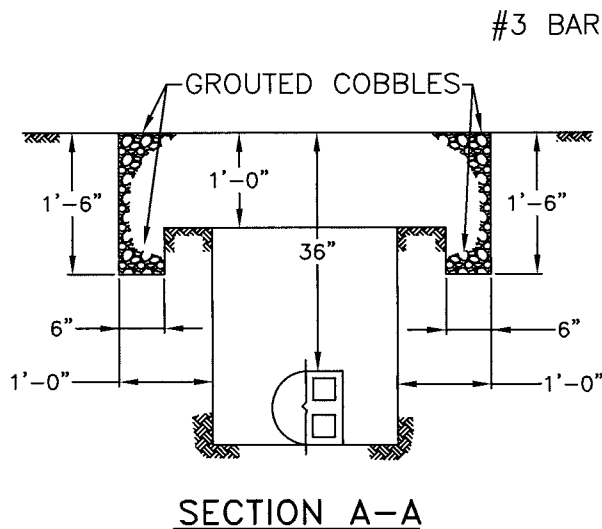
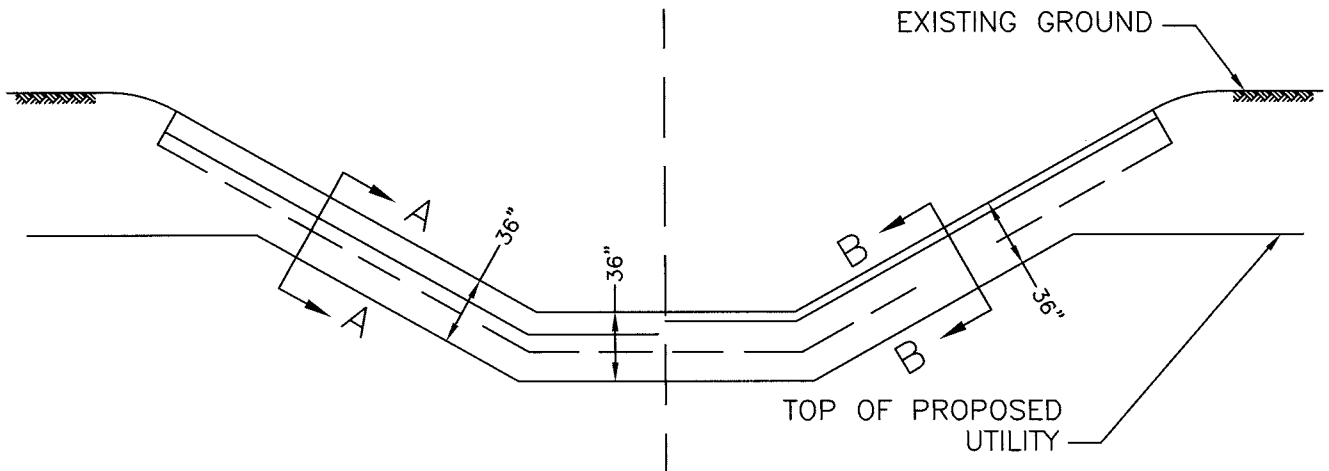

**NOTES:**

1. ALL UTILITY CROSSINGS OF EXISTING STREAMS SHALL BE AT LEAST 36" BELOW EXISTING CHANNEL SIDES AND BOTTOMS. DEEPER PLACEMENT MAY BE REQUIRED IF FUTURE CHANNEL IMPROVEMENTS ARE ANTICIPATED.
2. THE CUT SHALL BE SEALED AS SHOWN WITH GROUTED COBBLES OR CLASS B CONCRETE TO A WIDTH 1' EACH SIDE OF THE UTILITY TRENCH. ALL NATURAL STREAMS, AS SHOWN ON THE NATURAL STREAMS PLAN, SHALL UTILIZE GROUTED COBBLES.
3. CUT OFF WALLS SHALL CONFORM TO STANDARD DRAWING 9-10.
4. GRAVITY PIPES SHALL NOT BE SIPHONS.

<b>COUNTY OF YOLO</b> PLANNING AND PUBLIC WORKS DEPARTMENT		DATE: 08/05/08
<b>UTILITY STREAM CROSSING</b>		SHEET # 1 OF 1
<i>Paros Kerkas</i> COUNTY ENGINEER No. C42401	28 AUG. 08 APPROVAL DATE	DRAWING #: <b>9-13</b> NOT TO SCALE

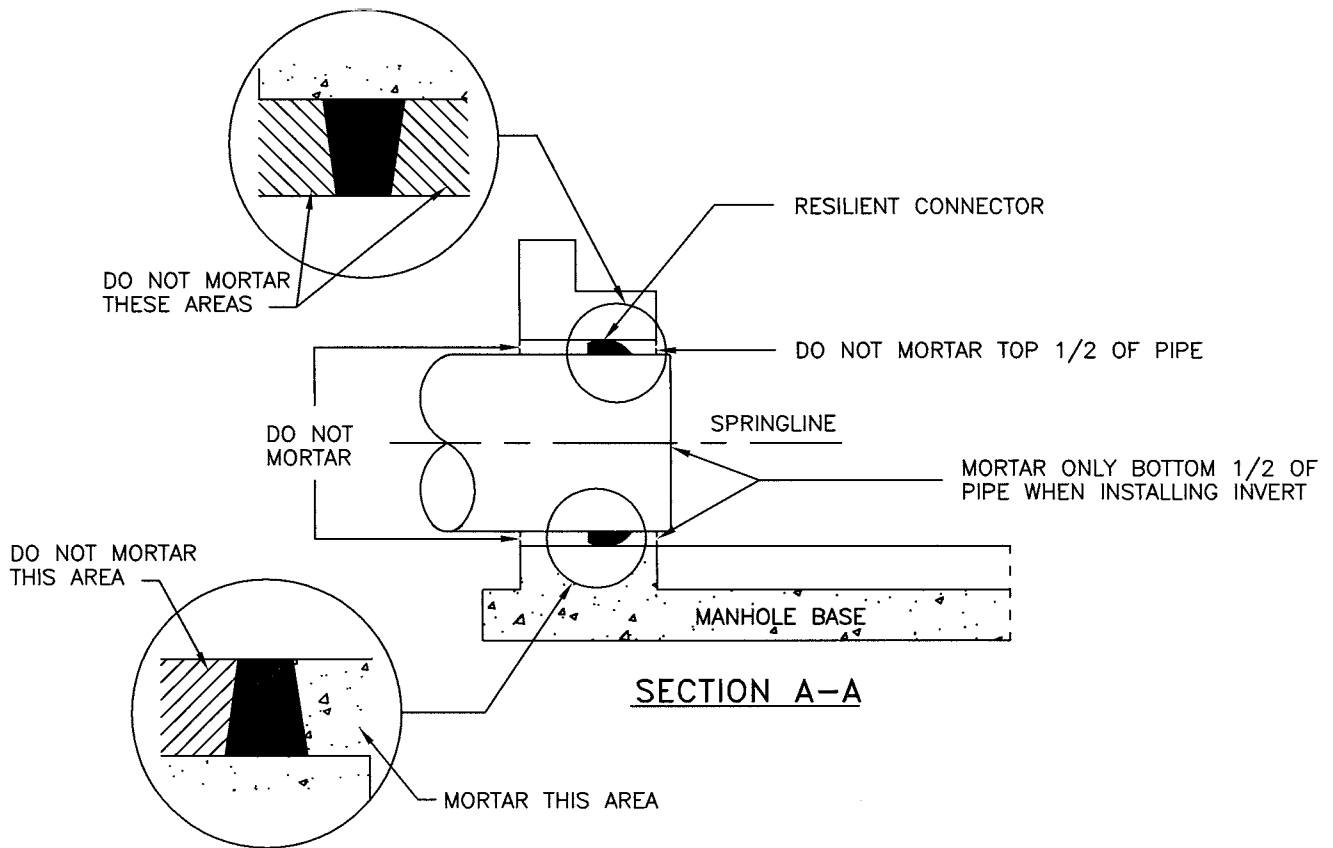

**SECTION A-A**

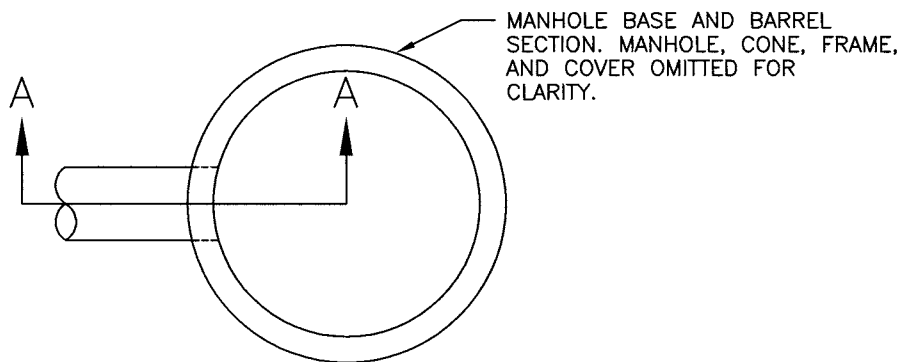

**PLAN**

**NOTES:**

1. TO HELP CREATE A FLEXIBLE AND WATERTIGHT JOINT, DO NOT PLACE MORTAR AROUND THE CONNECTOR ON THE OUTSIDE OF THE STRUCTURE OR AROUND THE TOP HALF OF THE CONNECTOR ON THE INSIDE WHEN COMPLETING THE INVERT WORK.
2. RESILIENT CONNECTORS SHALL BE A-LOK, PRESS-SEAL OR APPROVED EQUIVALENT.
3. ALL CONNECTORS SHALL MEET OR EXCEED THE REQUIREMENTS OF ASTM C-923.

<b>COUNTY OF YOLO</b> PLANNING AND PUBLIC WORKS DEPARTMENT		DATE: 08/05/08
FLEXIBLE CONNECTOR PIPE TO MANHOLE DETAIL		SHEET # 1 OF 1
<i>Panos Kofkas</i> COUNTY ENGINEER No. C42401	28 AUG-08 APPROVAL DATE	DRAWING #: <b>9-14</b> NOT TO SCALE



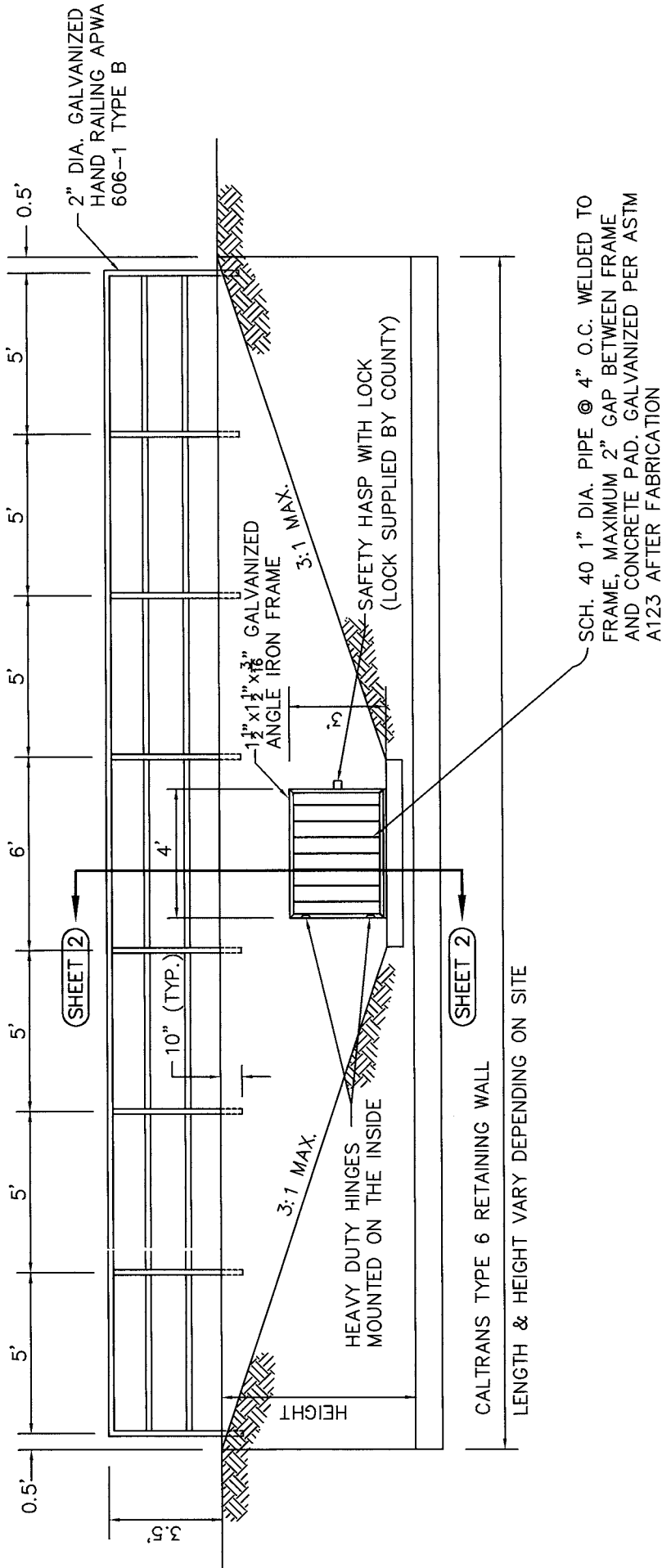

- NOTE:**
1. ALTERNATIVE OUTFLOW CONTROL STRUCTURES MAY BE APPROVED BY THE COUNTY ENGINEER.
  2. CONTROL STRUCTURE SHALL BE ACCESSIBLE IN WET WEATHER CONDITIONS.
  3. CONTROL STRUCTURE SHALL NOT BE LOCATED UNDER SIDEWALKS OR IN TRAFFIC AREAS.
  4. PROVIDE FORMED VERTICAL CRACK CONTROL JOINTS AT EACH SIDE OF GALVANIZED ANGLE IRON FRAME AND MIDPOINTS AT HANDRAIL SUPPORTS.
  5. PATCH HOLES IN FACE OF WIRE WITH NON-SHRINK GROUT TO PROVIDE UNIFORM APPEARANCE.

**COUNTY OF YOLO**  
 PLANNING AND PUBLIC WORKS DEPARTMENT  
 DETENTION BASIN OUTFLOW STRUCTURE  
 ELEVATION

DATE: 08/05/08

SHEET # 1 OF 4

DRAWING #: 9-15  
 NOT TO SCALE

*Ramesh Kulkarni*  
 COUNTY ENGINEER No. C42401  
 APPROVAL DATE: 28 AUG. 08

CENTRAL PRE-CAST DROP INLET MODEL #1R OR EQUIVALENT. BLOCKOUT TO MATCH 4'X3' OPENING CAST INTO THE RETAINING WALL. SET TO 0.75 FEET BELOW POND BOTTOM

2" DIA. GALVANIZED HAND RAILING (SCH. 40)

CALTRANS TYPE 6 RETAINING WALL

CENTRAL PRECAST TRANSITION SLAB WITH 24"x48" NON TRAFFIC BICYCLE PROOF GRATE (OR EQUIVALENT).

HDPE TRASH RACK WITH LIFTING HANDLE & 1" OPENINGS (BY PLASTIC SOLUTIONS INC. OR EQUIV.). MOUNT SCREEN TO FLOOR & SIDE WALLS PER MANUFACTURERS RECOMMENDATIONS SO SCREEN CAN BE LIFTED OUT OF 24"x48" GRATE DURING HIGH WATER CONDITIONS.

DESIGN HIGH WATER SURFACE (HWS)

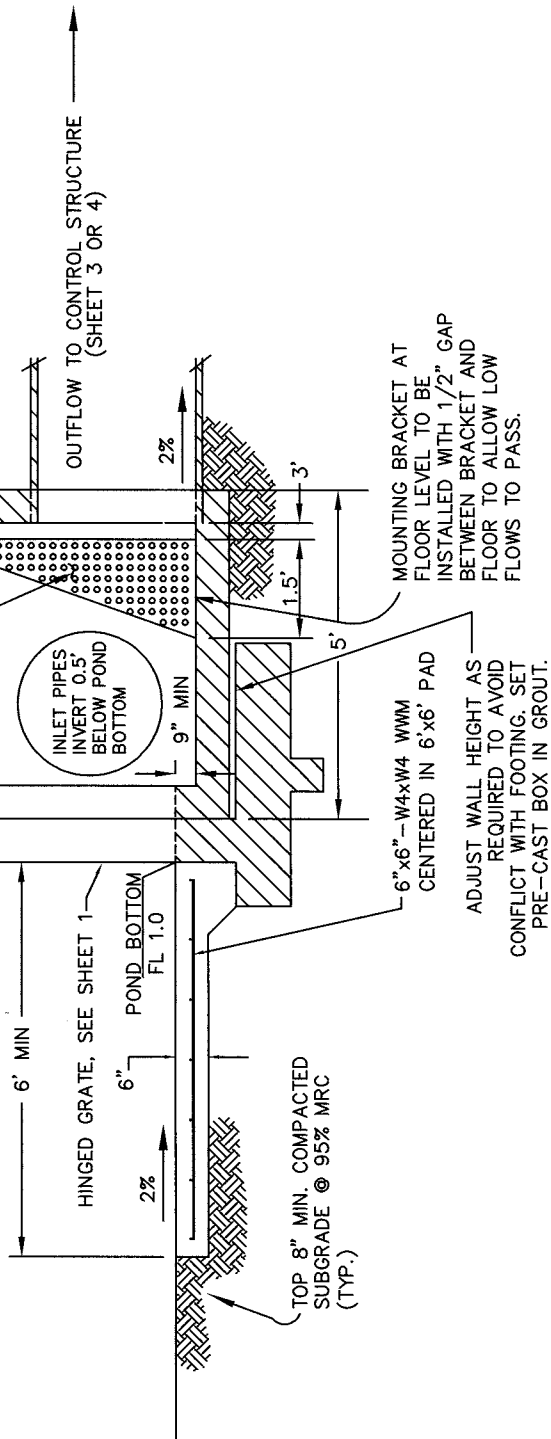

INLET PIPES INVERT 0.5' BELOW POND BOTTOM

HINGED GRATE, SEE SHEET 1

POND BOTTOM FL 1.0

6"x6" - W4xW4 WMM CENTERED IN 6'x6' PAD

ADJUST WALL HEIGHT AS REQUIRED TO AVOID CONFLICT WITH FOOTING. SET PRE-CAST BOX IN GROUT.

MOUNTING BRACKET AT FLOOR LEVEL TO BE INSTALLED WITH 1/2" GAP BETWEEN BRACKET AND FLOOR TO ALLOW LOW FLOWS TO PASS.

OUTFLOW TO CONTROL STRUCTURE (SHEET 3 OR 4)

COUNTY OF YOLO  
PLANNING AND PUBLIC WORKS DEPARTMENT  
DETENTION BASIN OUTFLOW STRUCTURE  
TRASH SCREEN ENCLOSURE

*Panas*  
COUNTY ENGINEER No. C42401  
28 AUG. 08  
APPROVAL DATE

DATE: 08/05/08  
SHEET # 2 OF 4  
DRAWING # 9-15  
NOT TO SCALE

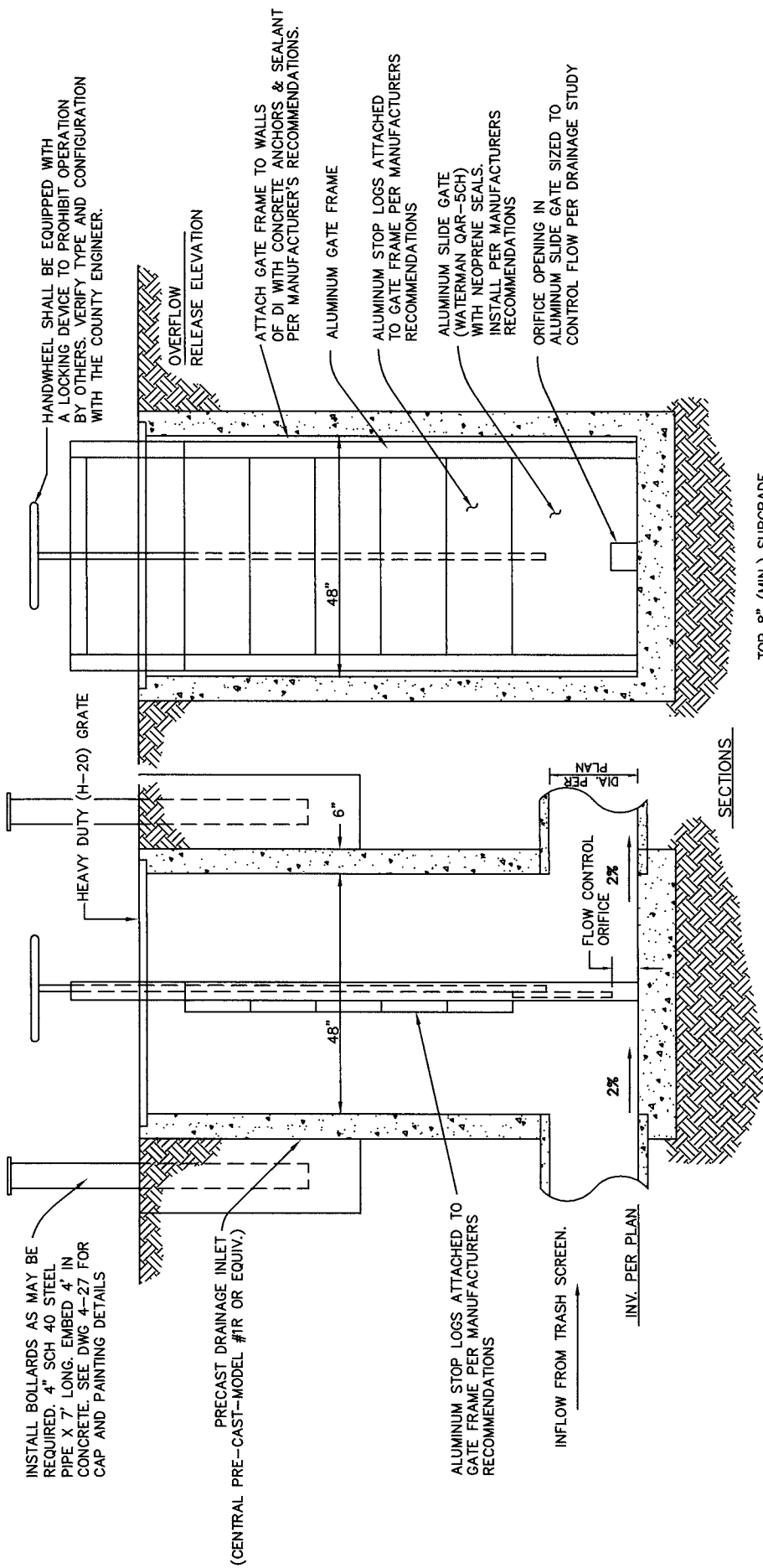

<p><b>COUNTY OF YOLO</b>          PLANNING AND PUBLIC WORKS DEPARTMENT</p>	<p>DATE:          08/05/08</p>
<p>DETENTION BASIN SLIDE GATE RESTRICTOR          OUTFLOW CONTROL STRUCTURE</p>	<p>SHEET #          3 OF 4</p>
<p><i>Parras Kalkas</i>          COUNTY ENGINEER No. C42401</p>	<p>DRAWING #:          9-15          NOT TO SCALE</p>
<p><i>28446.08</i>          APPROVAL DATE</p>	

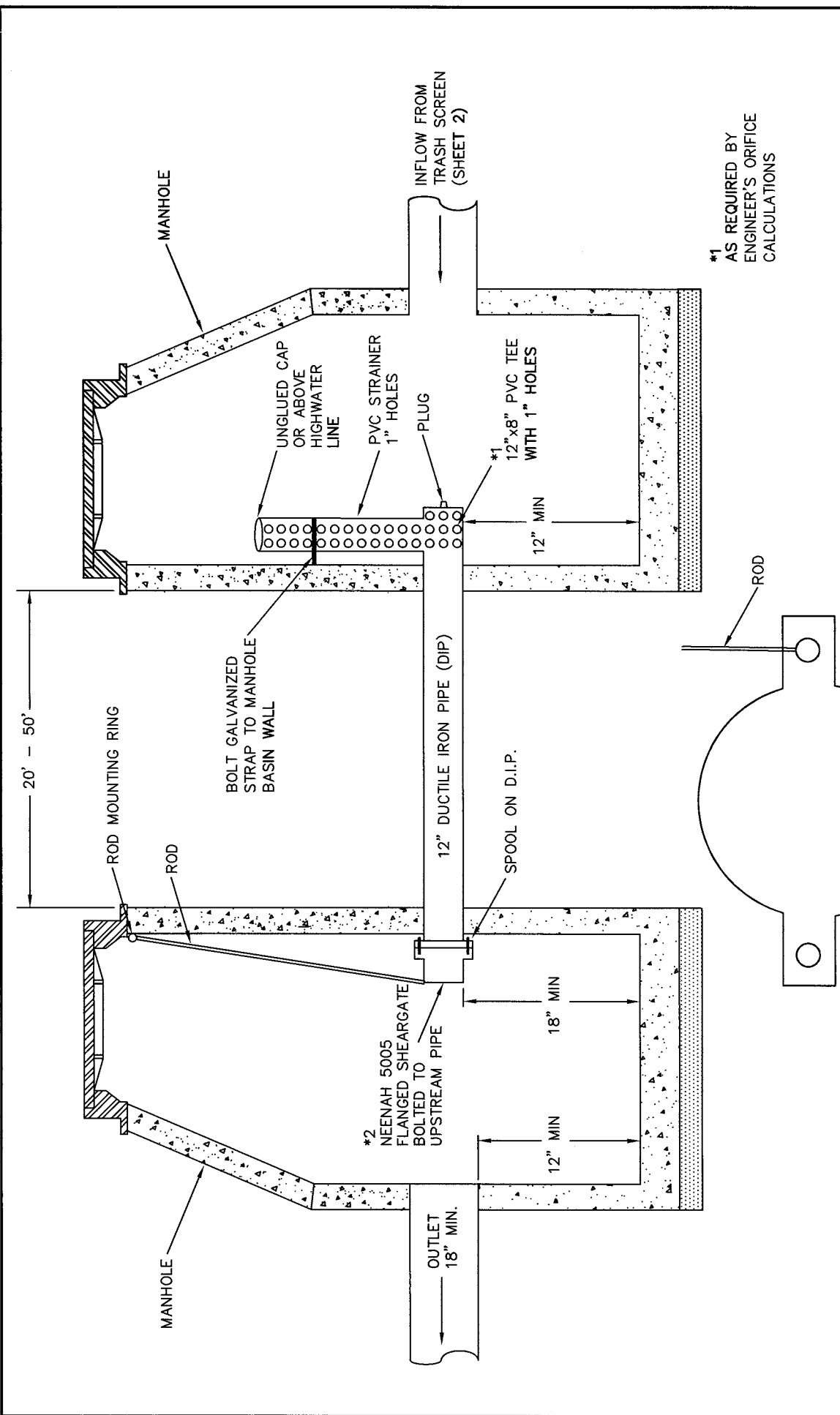

\*1 AS REQUIRED BY ENGINEER'S ORIFICE CALCULATIONS

\*2 ORIFICE SIZE PER ENGINEER'S CALCULATIONS RECTANGULAR OR CIRCULAR ORIFICE, AT THE BOTTOM OF SHEAR GATE.

<p>COUNTY OF YOLO PLANNING AND PUBLIC WORKS DEPARTMENT</p>		<p>DATE: 08/05/08</p>
<p>DETENTION BASIN SHEAR GATE RESTRICTOR OUTFLOW CONTROL STRUCTURE</p>		<p>SHEET # 4 OF 4</p>
<p><i>Carlos Kallas</i> COUNTY ENGINEER No. C42401</p>		<p>DRAWING #: 9-15 NOT TO SCALE</p>
<p>APPROVAL DATE 28 AUG. 08</p>		

**SECTION 10**

**GRADING**

<b>CONTENTS</b>	<b>Page</b>
10-1 General Requirements.....	10-1
10-2 Plan Sheet Details .....	10-1
10-3 Rolling Terrain Grading.....	10-2
10-4 Boundary Grading.....	10-2
10-5 Interior Grading .....	10-3
10-6 Retaining Walls.....	10-4
A. Reinforced Masonry Block or Concrete Retaining Walls.....	10-4
B. Building Permit Requirement .....	10-4
C. Drainage Requirements.....	10-4
10-7 Grading Near Trees.....	10-4
10-8 Certifying Pad Elevations .....	10-5
10-9 Maintenance of Access to Utility Facilities .....	10-6

**SECTION 10  
GRADING**

**10-1 GENERAL REQUIREMENTS**

Grading shall conform to Title 7 of the Yolo County Code, and these Improvement Standards.

A grading permit for subdivision improvements shall not be issued prior to Yolo County Board of Supervisors' approval of the Final Map and a bonded improvement agreement.

For grading and/or building permits not associated with a subdivision or a parcel map, based on project complexity, size, area topography, proximity to structures or facilities, or other concerns, the County Engineer may require a licensed civil engineer's stamped signature on a grading plan with the following wording:

**"CIVIL ENGINEER'S CERTIFICATION:**

I CERTIFY THAT THIS GRADING PLAN WILL NOT IMPOSE A GRADING, DRAINAGE, OR FLOODING IMPACT OR HAZARD TO THE PARCEL(S) TO BE GRADED, OR ANY UPSTREAM, DOWNSTREAM, OR ADJACENT PROPERTIES, AND ACKNOWLEDGE THAT I AM RESPONSIBLE TO VERIFY FINAL GRADING BY THE CONTRACTOR MATCHES THE DESIGN GRADES IN THIS GRADING PLAN.

\_\_\_\_\_ STAMP  
ENGINEER NAME, P.E. DATE"

**10-2 PLAN SHEET DETAILS**

In addition to the requirements of Section 3, the following items shall be included on grading plans:

- A. Street names and profile grade slopes
- B. Location and grate elevation of storm drain inlets
- C. Top of curb elevations at property line extensions, grade breaks, curb returns, and curb inlets.
- D. Typical final pad grading details, typical pad grading details for over-wintering.
- E. Proposed pad elevations, proposed lot lines and lot numbers, names of adjacent subdivisions and intersecting property lines.
- F. Typical sections across side yard property lines where the difference in finish pad elevations exceeds two feet. Delineated on the section shall be the side yard drainage swale and minimum distance between the proposed building and the side yard property line.
- G. Slope symbols for 3:1 slopes or steeper, where grade differences exceeds one foot.
- H. High points and valleys delineated.
- I. Flow directional arrows.

- J. Overland release grades and details.
- K. Existing spot elevations and/or contour lines on-site and off-site around perimeter of development. The spot elevations or contour lines shall be extended off-site for a minimum distance of 200 feet on adjacent undeveloped areas, and 500 feet for critical areas as may be required by the County Engineer.
- L. Existing vegetation including trees (variety, size and elevation at base of all trees nine inches or larger).
- M. Retaining wall details (symbols, construction details, limits, and top and bottom of wall elevations).
- N. Signature block for certification of pad elevations by Design Engineer and Geotechnical Engineer for subdivision projects, see Section 10-8.
- O. For all projects requiring import or export:
  - 1. Location and plan of borrow (cut) area or spoils (fill) disposal area.
  - 2. Cut or fill slopes as recommended by a Geotechnical Investigation Report, or:
    - i. Cut Slopes of 2:1 or flatter
    - ii. Fill slopes of 3:1 or flatter
  - 3. Finish fill heights of 3 feet or less; unless approved otherwise by County Engineer.
  - 4. Cut and fill areas shall not block or alter drainage patterns.
  - 5. All offsite cut and fill areas shall be permanently protected from erosion.
  - 6. Quantities of cut, fill, import and export.
- P. Erosion control details as required in Section 11.

### **10-3 ROLLING TERRAIN GRADING**

Grading or rolling terrain shall be accomplished in a manner whereby the profile of the rolling terrain is maintained as close to that which exists as practically possible. Interior cuts and fills shall be no greater than 5 feet unless approved by the County Engineer.

### **10-4 BOUNDARY GRADING**

Special attention shall be given to grading adjacent to the exterior perimeter property line of a development. All adverse effects to off-site properties adjacent to new developments shall be kept to an absolute minimum. Fills and cuts adjacent to the exterior perimeter property line shall be designed in accordance with the following.

- A. When grading along existing residential property, the grade should be, if at all possible, held equal to or lower than the existing property grades. When grades are to be raised higher than existing adjacent residential lots, a concrete or masonry retaining wall shall be used with an integral privacy fence, regardless of the difference in elevation. The exposed portion of the wall shall be architecturally surfaced. The wall shall be located as close to the property line as is feasible for construction. If permission can be obtained from the adjacent property owner(s), the wall should be placed on the property line or onto the lower lot and the fence relocated to the top

- of the wall. All walls higher than four (4) feet as measured from base of foundation to top of wall shall be substantiated with structural calculations stamped by a Registered Civil or Structural Engineer and a Building Permit shall be obtained from the Building Division.
- B.** Fills in excess of 2 feet shall not be allowed unless indicated on planning approval documents and permitted by project conditions of approval.
  - C.** If possible, all exterior slopes, fill or cut, shall be constructed offsite, with the property line being situated a minimum of one (1) foot inside the higher elevation as shown on Standard Drawing 10-1. If a right of entry cannot be obtained, a retaining wall shall be placed as near to property line as practicable.
  - D.** A recorded notarized right of entry shall be required for all off-site fills and grading prior to plan approval.
  - E.** Maximum slope shall be 2:1 or as specified by the soils report.
  - F.** All slopes steeper than 4:1 adjacent to the public right-of-way and private streets shall be protected with permanent erosion control measures.
  - G.** Fill material shall achieve 90 percent relative compaction certified by a Registered Geotechnical Engineer, except that fills under structures shall achieve 95% relative compaction.
  - H.** When a drainage swale or ditch is proposed to run adjacent to the property line, a level area, minimum width of five (5) feet is required between the property line and the top of the slope bank.

#### **10-5 INTERIOR GRADING**

Grading at interior property lines shall conform to the following.

- A.** Cross lot drainage is not allowed unless specifically approved by the County Engineer.
- B.** Retaining walls shall be required whenever adjacent side lot elevations differ by more than 1.0 foot.
- C.** Retaining Walls shall be shown on the plans and shall include all necessary information and details for construction. Retaining walls shall be concrete or masonry. All walls higher than four (4) feet as measured from base of foundation to top of wall shall be substantiated with structural calculations stamped by a Registered Civil Engineer and a Building Permit shall be obtained from the Building Department.
- D.** Property lines shall be situated a minimum of 1.0 foot inside the top of fill slopes when pad elevations differ by ½ foot or less. When retaining walls are used on interior property lines, the wall shall be situated on the high side.
- E.** Where pads on adjacent lots are 10 feet apart or less and the difference in elevation exceeds 1.5 feet, a retaining wall will be required.
- F.** The maximum earth slopes allowed shall be 2:1 (horizontal to vertical). Minimum asphalt concrete surface slopes shall be 1% and minimum concrete cement surface slopes shall be 0.3%. All proposed slopes that are 3:1 or steeper shall be shown on the plans by some type of slope symbol delineation.
- G.** Lots on the low side of streets and at sag points shall be graded in such a manner as to preclude flooding of the building pad area in the event of malfunction or overloading of the street drainage system. All building pad grades shall be a minimum of 1 foot above the overland release elevation.
- H.** Commercial developments shall not be allowed to "sheet drain" more than twenty-five feet of site frontage to a public street. Areas more than 25 feet from the street shall be graded to drain into an on-site drainage system.



**10-6 RETAINING WALLS****A. Reinforced Masonry Block or Concrete Retaining Walls:**

Masonry or concrete retaining walls shall conform to Caltrans Standard Plans, or shall be designed by a licensed Civil or Structural Engineer.

All walls higher than four (4) feet as measured from base of foundation to top of wall shall be substantiated with structural calculations stamped by a Registered Civil or Structural Engineer and a Building Permit shall be obtained from the Building Department.

For walls less than 4 feet as measured from base of foundation to top of wall, manufactured, modular, inter-locking, pre-cast concrete or masonry retaining walls may be substituted for reinforced cast in place concrete or masonry block construction. Design calculations and manufacturer's cut sheets and construction details shall be provided for review and approval prior to any such substitution.

Metal fence posts are required for privacy fences that are integral with concrete or masonry retaining walls.

**B. Building Permit Requirement:** A building permit shall be obtained for all retaining walls exceeding 4 feet in height (finished ground at base of wall to finished ground at top of wall) or when a fence greater than 6 feet high is an integral part of the wall.

**C. Drainage Requirements:** Grading shall be such that on-site-runoff will not flow to or over retaining walls. Suitable concrete ditches or other drainage collection devices shall be provided along retaining walls if the adjacent ground slopes to the wall. Surface drainage water shall not be collected using any required sub-surface ground water collection system behind the wall.

**10-7 GRADING NEAR TREES**

**A.** All trees with a six (6) inch diameter trunk or larger, measured 4-1/2 feet above the ground, in healthy condition, shall be identified on the plans as to size and species. Every reasonable effort shall be made to avoid removing trees or creating conditions adverse to the tree's health.

**B.** Grading within the drip line of trees to remain, especially oak trees, shall not be allowed. In the event that grading is required to provide essential subdivision improvements, then the services of an arborist certified by the International Society of Arboriculture (Certified Arborist) shall be retained to investigate and recommend appropriate measures to maximize the tree's potential for continued good health.

**C.** Trees with an six (6) inch or larger trunk diameter that are questionable as to health or safety shall be reviewed by a Certified Arborist and appropriate actions recommended.

**D.** Cross sections or other detailed design and topographic information may be required where trees are located adjacent to roadways, new slopes or critical areas. This information will be used to determine the appropriateness of recommended improvements to maximize the tree's potential for continued good health.

- E.** The following development control measures shall be placed as notes and incorporated into the designs of projects that have trees to be preserved:
1. Only those trees marked with an "X" in paint at the base of the trunk are to be removed during construction.
  2. During construction, there shall be no grading, trenching, earth removal or addition, building pad formation or earth alteration of any kind within the drip line of any tree to be preserved.
  3. Prior to the construction phase of the project, a physical barricade shall be erected and maintained coincidental to the drip lines of all trees to be preserved. Within this barrier no construction related activities shall be allowed including, but not limited to, vehicular parking or material storage. The physical barricade shall be T-bars and 4-foot high wire mesh fencing, or orange fabric mesh.
  4. No trenching shall be allowed within the drip lines of trees to be preserved. If it is absolutely necessary to install underground utilities within the drip lines of trees, then boring or drilling methods shall be used.
  5. Paving within the drip lines of trees shall be minimized. When it is absolutely necessary, porous paving material such as turf-stone, interlocking pavers, or other materials designed by a Certified Arborist, and approved by the County Engineer, shall be used and no paving shall occur within 10 feet of their trunks. When asphalt or concrete paving is installed, piped aeration systems can be used, as an alternate to porous paving material, only when the paving material is installed within 6 inches from the original ground elevation. The piped aeration systems shall not be installed any deeper than 1 foot from the original ground elevation. A Certified Arborist or Licensed Landscape Architect shall approve the piped aeration system prior to construction. No aeration systems shall be constructed within the County or public right of way.

**10-8 CERTIFYING PAD ELEVATIONS**

Upon completion of the grading and prior to acceptance of the subdivision improvements by the County, the Design Engineer shall verify the final pad elevations. The elevations shall be verified at the center and the corner of each pad. Elevation deviations of more than 0.20 feet shall be noted on the plans.

A signature block, shown below, certifying that final graded elevations in the field are the same as those shown on the plans, shall be included on the subdivision grading plans. The Design Engineer shall sign the signature block, certifying to the above, and provide one set of mylar or polyester film original record (as-built) grading plans to the County Engineer.

<b>CERTIFICATE OF COMPLIANCE</b>			
I hereby certify that the grades shown on these plans and as approved by the Public Works Division have been constructed to within 2/10th of one (1) foot of their indicated elevation for all lot pads and 1/10th of one (1) foot for other improvements shown.			
<b><i>(signature)</i></b> _____			
Project Engineer (printed name)	PE Number	Expiration Date	Date
I hereby certify that the pads for the following lots for this project have been tested for compaction in accordance with generally accepted test methods, and based upon the results of these tests, the compaction of said pads conforms to the recommendations of this project's geotechnical report:			
Lots: _____			
I also state that our firm observed the grading operations to a sufficient extent to evaluate conformance with the project's geotechnical report as approved by the County, and further state that based upon our observations, the grading for this subdivision conforms to the recommendations of said geotechnical report.			
<b><i>(signature)</i></b> _____			
Engineer (printed name)	PE Number	Expiration Date	Date

In addition, stormwater detention basin volumes shall be field verified. The Design Engineer shall submit volume calculations to demonstrate that stormwater detention basins provide the volume needed to detain stormwater, as required by the hydrology study.

**10-9 MAINTENANCE OF ACCESS TO UTILITY FACILITIES**

Continuous, suitable access shall be maintained during all stages of construction of any facility owned or operated by the County or other public agency or a utility providing essential services, such as, but not limited to, sanitary sewer, water, drainage, electricity, gas, telephone/communications, etc.

<b>Standard Drawings</b>		
<b>Section 10 – Grading</b>		
<b>Drawing</b>	<b>Sheets</b>	<b>Description</b>
10-1	1	Exterior Perimeter Property Line Grading for Fill Areas

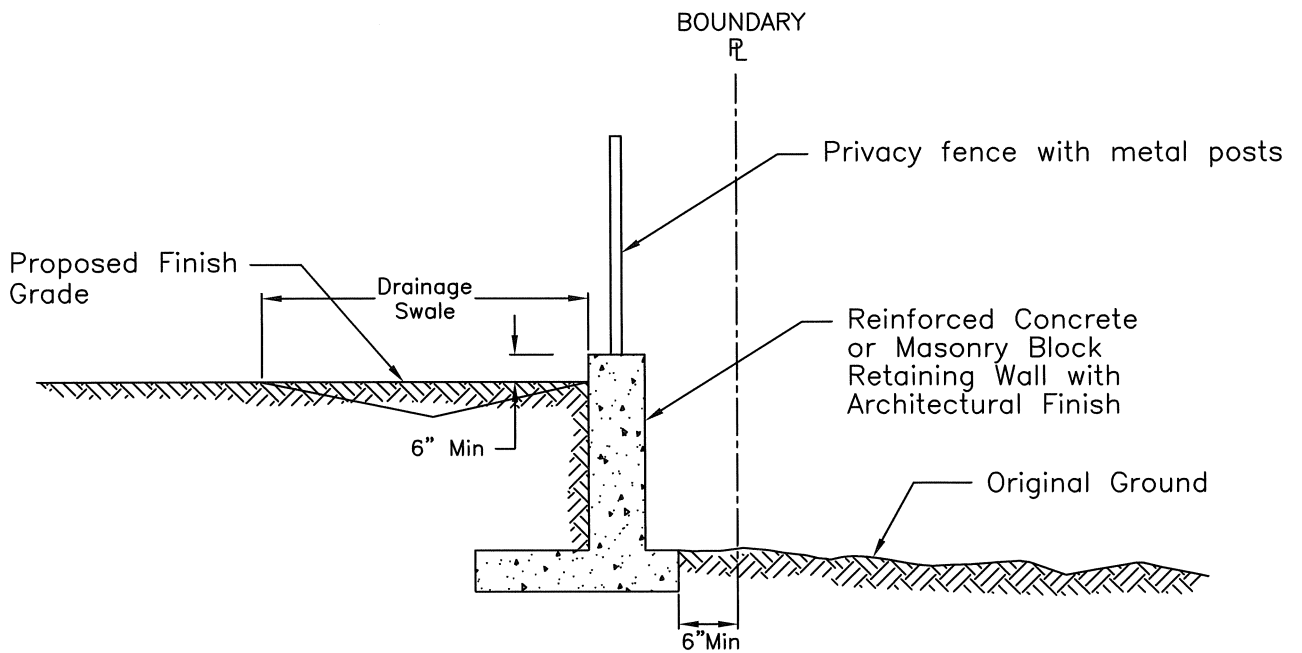
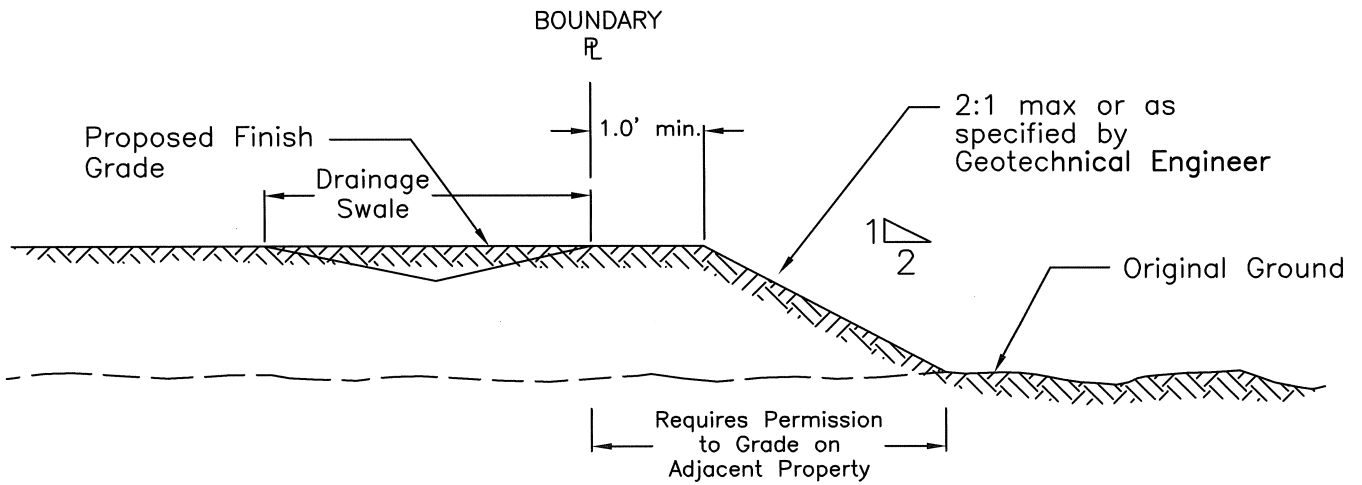

**NOTES:**

1. RETAINING WALL DESIGN MUST BE SIGNED AND SEALED BY A LICENSED PROFESSIONAL ENGINEER.
2. STRUCTURAL CALCULATIONS MUST BE INCLUDED.
3. BUILDING PERMIT REQUIRED FOR RETAINING WALLS EXCEEDING 4' IN HEIGHT, MEASURED FROM THE BOTTOM OF THE FOOTING TO THE TOP OF THE WALL.

<b>COUNTY OF YOLO</b>		DATE:
PLANNING AND PUBLIC WORKS DEPARTMENT		08/05/08
EXTERIOR PERIMETER PROPERTY LINE GRADING FOR FILL AREAS		SHEET # 1 OF 1
<i>Panos Kakkas</i> 28 AUG. 08		DRAWING #:
COUNTY ENGINEER No. C42401		10-1
APPROVAL DATE		NOT TO SCALE

**SECTION 11**

**STORMWATER QUALITY, EROSION AND SEDIMENT CONTROL**

<b>CONTENTS</b>	<b>Page</b>
11-1 ABBREVIATIONS / ACRONYMS .....	11-1
11-2 GOOD HOUSEKEEPING PRACTICES .....	11-1
11-2.1 ALL CONSTRUCTION SITES REGARDLESS OF SIZE .....	11-1
11-2.2 CONSTRUCTION PROJECTS INVOLVING PAINT WORK .....	11-2
11-2.3 CONSTRUCTION PROJECTS INVOLVING CEMENT AND CONCRETE WORK.....	11-3
11-2.4 CONSTRUCTION PROJECTS INVOLVING ROADWORK/PAVEMENT CONSTRUCTION .....	11-3
11-3 CONSTRUCTION PROJECTS WITH SOIL DISTURBANCE OF AN ACRE OR MORE: ....	11-3
11-3.1 NOTICE OF INTENT FROM THE REGIONAL WATER QUALITY CONTROL BOARD .....	11-4
11-3.2 STORM WATER POLLUTION PREVENTION PLAN .....	11-4
11-3.3 COUNTY APPROVAL PRIOR TO PROJECT COMMENCEMENT.....	11-4
11-4 STORMWATER POLLUTION PREVENTION BEST MANAGEMENT PRACTICES FOR CONSTRUCTION ACTIVITIES:.....	11-5
11-4.1 CONSTRUCTION SEQUENCE SCHEDULE.....	11-5
11-4.2 CONSTRUCTION SITE BMP'S.....	11-5
11-4.3 EROSION AND SEDIMENT CONTROL PLAN .....	11-6
11-4.4 TOP SOILING .....	11-7
11-4.5 PRESERVATION OF EXISTING VEGETATION.....	11-7
11-4.6 HYDROSEEDING .....	11-8
11-4.7 SOIL BINDERS .....	11-8
11-4.8 STABILIZED CONSTRUCTION ACCESS.....	11-9
11-4.9 SEDIMENT TRAP.....	11-9
11-4.10 SEDIMENT BASIN .....	11-10
11-4.11 GEOTEXTILES, MATS, AND EROSION CONTROL BLANKETS.....	11-11
11-4.12 SILT FENCE .....	11-12
11-4.13 STRAW BALE BARRIER .....	11-12
11-4.14 INLET SEDIMENT CONTROL BARRIERS AND FILTERS .....	11-13
11-4.15 STRAW MULCH AND HYDRAULIC MULCHING.....	11-13
11-4.16 FIBER ROLLS.....	11-14
11-4.17 CONCRETE WASHOUTS.....	11-15
11-4.18 CLEAN UP .....	11-15
11-4.19 STREET SWEEPING AND VACUUMING .....	11-15
11-5 PERMANENT POST-CONSTRUCTION STORMWATER POLLUTION CONTROLS FOR NEW DEVELOPMENT OR REDEVELOPMENT PROJECTS.....	11-16
11-5.1 PROJECT CATEGORIES SUBJECT TO THESE DESIGN STANDARDS: .....	11-16
11-5.2 DESIGN STANDARDS APPLICABLE TO ALL CATEGORIES.....	11-16
11-5.2.1 <i>Maintain Pre-Development Peak Stormwater Discharge Rates</i> .....	11-16
11-5.2.2 <i>Conserve Natural Areas</i> .....	11-16
11-5.2.3 <i>Minimize Stormwater Pollutants of Concern</i> .....	11-17
11-5.2.3 <i>Protect Slopes and Channels</i> .....	11-17
11-5.2.5 <i>Concrete Storm Drain System Stamp or Epoxied Placards</i> .....	11-17

11-5.2.6 *Outdoor Material Storage Areas*..... 11-18  
11-5.2.7 *Trash Storage Areas* ..... 11-18  
11-5.2.8 *Ongoing BMP Maintenance* ..... 11-18  
11-5.2.9 *Structural or Treatment Control BMPs*..... 11-19  
11-5.3 DESIGN STANDARDS APPLICABLE TO INDIVIDUAL PRIORITY PROJECT CATEGORIES ..... 11-19  
11-5.3.1 *100,000 Square Foot Commercial Developments*..... 11-19  
11-5.3.2 *Restaurants* ..... 11-20  
11-5.3.3 *Retail Gasoline Outlets*..... 11-20  
11-5.3.4 *Automotive Repair Shop & Automobile Dismantling* ..... 11-21  
11-5.3.5 *Parking Lots*..... 11-21

## SECTION 11 STORMWATER QUALITY, EROSION AND SEDIMENT CONTROL

### 11-1 ABBREVIATIONS / ACRONYMS

<b>Administrator</b>	Assistant Director of the County of Yolo Planning Public Works Department and his or her designee.
<b>BMP</b>	Best Management Practice
<b>CWA</b>	Clean Water Act
<b>General Permit</b>	State Water Resources Control Board Order No. 00-08 – DWQ National Pollutant Discharge Elimination System General Permit # CAS000002, or its successor permit
<b>MCM</b>	Minimum Control Measures
<b>NOI</b>	Notice of Intent
<b>NOT</b>	Notice of Termination
<b>NPDES</b>	National Pollutant Discharge Elimination System
<b>NRCS</b>	National Resource Conservation Service
<b>RWQCB</b>	Regional Water Quality Control Board
<b>SWMP</b>	Stormwater Management Plan
<b>SWPPP</b>	Storm Water Pollution Prevention Plan
<b>SWRCB</b>	State Water Resources Control Board
<b>Wet Season</b>	October 1 <sup>st</sup> through April 30 <sup>th</sup>
<b>WPCP</b>	Water Pollution Control Program

### 11-2 GOOD HOUSEKEEPING PRACTICES

All construction sites shall be required to follow these Good Housekeeping Practices regardless of the project size or number of square feet of soil disturbed.

- A. Definition – The BMPs that prevent pollutants from entering stormwater drainage systems or watercourses by limiting or reducing the potential at their source. Good Housekeeping Practices involve the day-to-day operations of the construction site, which involve keeping the site clean and orderly.
- B. Applicability – The deployment and implementation of Good Housekeeping Practices depends on the conditions and applicability described below:

#### *11-2.1 All Construction Sites Regardless of Size*

1. Identify all storm drains, drainage swales and creeks located near the construction site and make sure all subcontractors are aware of their locations to prevent pollutants from entering them.
2. Clean up and properly dispose of all leaks, drips, and other spills immediately.
3. Refuel vehicles and heavy equipment in one designated location or off-site if possible.



4. Wash vehicles at an appropriate off-site facility. If equipment must be washed on-site, do not use soaps, solvents, degreasers, or steam cleaning equipment, and prevent wash water from entering the storm drain or watercourse.
5. Never wash down pavement or surfaces where materials have spilled. Use dry cleanup methods whenever possible.
6. Avoid contaminating clean runoff from areas adjacent to your site by using berms and/or temporary or permanent drainage ditches to divert water flow around the site.
7. Keep materials out of the rain. Schedule clearing or heavy earth moving activities for periods of dry weather. Cover exposed piles of soil, construction materials and wastes with plastic sheeting or temporary roofs. Before it rains, sweep and remove materials from surfaces that drain to storm drains or watercourses.
8. Place trash cans around the site to reduce litter. Dispose of non-hazardous construction wastes in covered dumpsters or recycling receptacles. Recycle leftover materials whenever possible.
9. Dispose of all wastes properly. Materials that cannot be reused or recycled must be taken to an appropriate landfill or disposed of as hazardous waste.
10. Cover open dumpsters with plastic sheeting or a tarp during rainy weather if your dumpster does not have a cover. Secure the sheeting or tarp around the outside of the dumpster. If your dumpster has a cover, make sure it is closed and secured.
11. Train your employees and inform subcontractors about the stormwater requirements and their own responsibilities.
12. Locate portable toilets a minimum of 25 feet away from drain inlets, watercourses and traffic circulation. Portable toilets shall be secured to prevent overturning. Regular service and waste disposal shall be provided. Untreated raw wastewater should never be discharged or buried. Install a secondary containment around portable toilets adequate for handling spills during servicing.
13. Appropriate measures shall be provided to prevent dust nuisance. Water trucks shall be used to dampen the surface to control dust. Care shall be taken to not overwater causing sediment-laden runoff. All earthwork operations shall cease when wind speeds exceed 20 mph for one hour or more.

#### ***11-2.2 Construction Projects Involving Paint Work***

1. Non-hazardous paint chips and dust from dry stripping and sand blasting may be swept up or collected in plastic drop cloths and disposed of as trash.
2. Chemical paint stripping residue and chips and dust from marine paints or paints containing lead or tributyltin must be disposed of as a hazardous waste.
3. When stripping or cleaning building exteriors with high-pressure water, cover or berm storm drain inlets and prevent discharge into watercourses. If possible (and allowed by the local wastewater treatment plant), collect (mop or vacuum) building cleaning water and discharge to the sanitary sewer, where allowed.
4. Never clean brushes, paint containers or equipment or allow rinse water to enter the street, gutter, storm drain, or watercourses.
5. For water-based paints, paint out brushes, or other painting equipment, to the extent possible and rinse to a drain leading to the sanitary sewer (i.e., indoor plumbing).
6. For oil-based paints, paint out brushes, or other painting equipment, to the extent possible, and filter and reuse thinners and solvents. Dispose of unusable thinners and residue as hazardous waste.
7. Recycle, return to supplier or donate unwanted water-based (latex) paint.
8. Dried latex paint may be disposed of in the garbage.

9. Unwanted oil-based paint (that is not recycled), thinners, and sludges must be disposed of as hazardous waste.

### ***11-2.3 Construction Projects Involving Cement and Concrete Work***

1. Avoid mixing excess amounts of fresh concrete or cement mortar on-site.
2. Store dry and wet materials under cover, protected from rainfall and runoff.
3. Wash out concrete transit mixers only in designated washout areas where the water will flow into settling ponds or onto dirt or stockpiles of aggregate base or sand. Pump water from settling ponds to the sanitary sewer, where allowed. Whenever possible, recycle washout by pumping back into mixers for reuse. Never allow washout to enter the street, storm drains, drainage ditches, or other watercourses.
4. Whenever possible, return contents of mixer barrel to the yard for recycling. Dispose of small amounts of dried excess concrete, grout, and mortar in the trash.

### ***11-2.4 Construction Projects Involving Roadwork/Pavement Construction***

1. Apply concrete, asphalt, and seal coats during dry weather to prevent contaminants from contacting stormwater runoff.
  2. Cover storm drain inlets and manholes when paving or applying seal coats, slurry seal, fog seal, etc.
  3. Always park paving machines over drip pans or absorbent materials, since they tend to drip continuously.
  4. When making saw-cuts in pavement, use as little water as possible. Cover storm drain inlets completely with filter fabric during the sawing operation and contain the slurry by placing sandbags, gravel bags, gravel dams, or other approved BMP around the storm drain inlets. After the liquid drains or evaporates, shovel or vacuum the slurry residue from the pavement or gutter and dispose of it properly.
  5. Wash down exposed aggregate concrete pavement only when the wash water can: (1) flow onto a dirt area; (2) drain onto a bermed surface from which it can be pumped and disposed of properly; or (3) be vacuumed from the area along the curb where sediment has accumulated by blocking a storm drain inlet.
  6. Allow aggregate rinse water to settle, and pump the water to the sanitary sewer if allowed by the local wastewater authority.
  7. Never wash sweepings from exposed aggregate concrete pavement into a street, storm drain, or watercourse. Collect and return to aggregate base stockpile, or dispose of it with the trash.
  8. Recycle broken concrete and asphalt.
- C. Design – Owners, contractors, and Developers shall be vigilant regarding the implementation of these BMPs, including making them a part of all prime and subcontract agreements.
- D. Maintenance – Being vigilant regarding Good Housekeeping Practices could prevent an inadvertent violation, the imposition of fines, and project delays. If procedures are not implemented properly or if the BMPs are compromised, the stormwater discharge will then be subject to the sampling and analysis requirements contained in the General Permit Section B, “Monitoring Program and Reporting Requirements”.

## **11-3 CONSTRUCTION PROJECTS WITH SOIL DISTURBANCE OF AN ACRE OR MORE**

Construction activities that disturb one or more acres of land are required to comply with the Statewide National Pollutant Discharge Elimination System (NPDES) general permit that regulates stormwater leaving a construction site. Construction sites of less than one acre, but part of a larger project that covers one or more acres, regardless of phasing, must also comply. Construction activities that essentially

maintain existing facilities, and do not involve a change in grade, are not required to comply with the General Permit.

- A. Definition – One acre of disturbed land is equivalent to the mathematical total of 43,560 square feet, regardless of geometric configuration. Disturbed land means any soil moved from its original location by any action or activity exposing it to rain runoff or wind erosion.
- B. Applicability – Construction activities subject to regulation include, but are not limited to:
  - 1. Clearing
  - 2. Grading
  - 3. Stockpiling
  - 4. Excavation

Construction activities not subject to regulation include, but are not limited to:

- 1. Routine maintenance
- 2. Emergency construction required to protect public health and safety

Dischargers should confirm with the local RWQCB that a routine maintenance or emergency construction activity is subject to the General Permit.

### ***11-3.1 Notice of Intent From the Regional Water Quality Control Board***

Discharger shall submit a Notice of Intent (NOI) to obtain coverage under the general permit.

### ***11-3.2 Storm Water Pollution Prevention Plan***

- 1. The general permit requires the discharger to develop and implement a Storm Water Pollution Prevention Plan (SWPPP), which specifies the Best Management Practices (BMPs) that will be used to prevent all construction pollutants from contacting storm water and with the intent of keeping all products of erosion from moving off site into receiving waters.
- 2. The discharger is to take every measure practicable to eliminate or reduce non-storm water from entering storm drainage systems or other watercourses.
- 3. The discharger is required to perform inspections of all BMPs before, during, and after a storm event.
- 4. A full copy of the SWPPP, along with other required documents, must be maintained at the job site until completion of the project and a Notice of Termination (NOT) has been filed with the RWQCB.

### ***11-3.3 County Approval Prior to Project Commencement***

- 1. County Stormwater Management approval must be received before the start of any construction work disturbing one or more acres of land or that is a part of a larger project that disturbs one or more acres of land.
- 2. To receive County approval all dischargers must submit a copy of their NOI and SWPPP to the County office and pay applicable fees.
- 3. County staff will review the SWPPP for completeness and any required changes or additional information will have to be submitted to the County before a grading or building permit can be approved. The changes or additions must also be attached to the contractor's SWPPP that is kept at the project site.
- C. Design – The discharger is to develop and implement an adequate SWPPP for the particular aspects of the project. Appropriate BMPs must be carefully chosen and then properly installed, inspected, and maintained according to the approved standard designs.
- D. Maintenance – Follow all Good Housekeeping Practices; inspections and maintenance of BMPs is the key to a successful water pollution prevention system. Document all SWPPP training of

personnel, BMP inspections, revisions and repairs done on the project and keep these reports with the SWPPP on the project job site.

## **11-4 STORMWATER POLLUTION PREVENTION BEST MANAGEMENT PRACTICES FOR CONSTRUCTION ACTIVITIES**

### ***11-4.1 Construction Sequence Schedule***

- A. Definition – A written plan developed to include sequencing of construction activities and the implementation of BMP's to control erosion and sedimentation.
- B. Applicability – Every construction project meeting the 1-acre project area disturbance threshold shall have proper sequencing of construction activities and the implementations of BMP's especially when soil is to be disturbed during the rainy season.
- C. Design – Consideration must be given to the local climate and to reducing the amount and duration disturbed soil is exposed to erosion from wind, rain, runoff, and vehicle tracking while construction activities are being performed.
  1. Outline all land disturbing activities throughout each phase of the project.
  2. List all BMP's necessary to control erosion and sedimentation during both the wet and dry seasons until project completion.
  3. Combine these lists to provide a practical and effective Construction Sequence Schedule.
- D. Maintenance – This is a dynamic-evolving schedule, allow room for alterations and updating as conditions change. Give due consideration to environmental constraints such as the nesting season of specific birds and the optimal times for seeding and re-vegetation.
  1. Inspect and verify that work is progressing in accordance with the schedule. If progress has deviated take corrective action.
  2. Amend the schedule to reflect changes in construction progress or critical path changes.
  3. Amend the schedule prior to the rainy season to show updated information on the deployment and implementation of construction site BMP's.

### ***11-4.2 Construction Site BMP's***

Standard Improvement BMP's for use During Construction Projects:

1. Access points to the construction site shall be constructed in accordance with Stabilized Construction Access (Section 11-4.8).
2. Existing vegetation shall be preserved as directed in Preservation of Existing Vegetation (Section 11-4.5) and Silt Fence (Section 11-4.12).
3. Perimeter protection along property lines shall follow guidelines in Preservation of Existing Vegetation (Section 11-4.5), Hydroseeding (Section 11-4.6), and Silt Fence (Section 11-4.12).
4. Slopes greater than 3 percent shall be temporarily seeded and slopes greater than 3:1 (H:V) shall have Hydroseeding (Section 11-4.6), Straw Mulch and Hydraulic Mulching (Section 11-4.15), Fiber Rolls (Section 11-4.16), and Geotextiles, Mats, and Erosion Control Blankets (Section 11-4.11) installed as required by site conditions.
5. The toe of all slopes greater than 3:1 (H:V) shall have Silt Fence (Section 11-4.12) and/or Fiber Roll (Section 11-4.16) erosion and sediment control installed.
6. Disturbed soil areas behind the curb or back of walk shall be stabilized using Straw Mulch and Hydraulic Mulching (Section 11-4.15), Soil Binders (Section 11-4.7), or Geotextiles, Mats, and Erosion Control Blankets (Section 11-4.11) in conjunction with Hydroseeding (Section 11-4.6) and/or Top Soiling (Section 11-4.4). Surface treatments shall extend to the greater of 20 feet or to the top of the slope.
7. Roadway Subgrades shall have Fiber Rolls (Section 11-4.16), Silt Fence (Section 11-4.12), or Sediment Trap (Section 11-4.9) erosion and sediment controls installed.

8. Dead-end streets, to be extended in the future, shall have Preservation of Existing Vegetation (Section 11-4.5), Top Soiling (Section 11-4.4), Hydroseeding (Section 11-4.6), Sediment Trap (Section 11-4.9) or other applicable BMP to minimize the transport of sediment onto or from the improved surface.
9. Projects that include detention basins shall have a Sediment Basin (Section 11-4.10).
10. Existing drainage inlets shall be protected from sediment-laden runoff using Inlet Sediment Control Barriers & Filters (Section 11-4.14). New or retrofit drainage inlets shall have a message stamp according to Concrete Stamp or Epoxied Placards (Section 11-5.2.5).
11. Use of temporary or portable sanitary and septic waste systems shall be treated or disposed of in accordance with state and local requirements. Temporary or portable toilets shall be located a minimum of 25 feet from drain inlets, watercourses and traffic circulation. A licensed hauler shall service and dispose of sanitary waste at frequencies great enough to insure the facility does not overflow.
12. Each construction site shall provide designated paint and waste disposal locations, as necessary, that comply with CASQA Construction Handbook Section 4-2, "Waste Management & Materials Pollution Control BMP's".
13. A BMP installation schedule shall be included with the Improvement Plans that follow Construction Sequence Schedule (Section 11-4.1) guidelines. The schedule shall include the BMP's for both the wet season and dry season.

Design information for BMP's is available from the following resources:

- A. Caltrans guidelines and handbooks available on line at:  
<http://www.dot.ca.gov/hq/env/stormwater/special/newsetup/>
- B. Several publications from the State Water Resources Control Board's website at:  
<http://www.swrcb.ca.gov/stormwtr/links.html>
- C. California Stormwater Quality Association's 2003 Stormwater Best Management Practice (BMP) Handbooks, which are available online at: <http://www.cabmphandbooks.com>.
- D. National Resource Conservation Service Planning & Design Manual available online at <http://www.wsi.nrcs.usda.gov/products/UrbanBMP's/water.html>.
- E. Additional sources of information can be found in the following:
  1. Storm Water Quality Task Force. 1993. California Storm Water Best Management Practice Handbook – Municipal.
  2. Storm Water Quality Task Force. 1993. California Storm Water Best Management Practice Handbook – Industrial / Commercial.
  3. Erosion and Sediment Control Field Manual prepared by California Regional Water Quality Control Board, San Francisco, Bay Region, 1997.
  4. Blueprint for a Clean Bay. "Best Management Practices to Prevent Storm Water Pollution from Construction-Related Activities", published by AASMAA and the Santa Clara Valley Non-point Source Pollution Control Program. 1995.

These resources do not constitute an exhaustive list. The BMP resources listed above are intended to assist the construction site and maintenance managers in selecting strategies for minimizing pollution. However, the County does not specifically endorse all or any of the individual BMP's given in these guidelines, manuals and handbooks. Submit the selected BMPs to the County for approval.

#### ***11-4.3 Erosion and Sediment Control Plan***

- A. Improvement Plans for all construction projects, regardless of the square feet of disturb land, shall include an Erosion and Sediment Control Plan, which shall comply with these standards.
- B. Erosion and Sediment Control Plans shall include erosion controls and sediment controls from this Section 11 to minimize erosion and the transport of sediments. These plans may be incorporated into the Grading Plan, included in the project SWPPP, or submitted on separate sheets for clarity.

- C. Additionally, landowners meeting the 1-acre project area disturbance threshold shall comply with the requirements delineated in Section 11-3 prior to commencing construction activities. Coverage under the State's General Permit can be obtained by filing an NOI with the SWRCB including a vicinity map, developing a SWPPP, and paying the appropriate fee.

#### ***11-4.4 Top Soiling***

- A. Definition – Salvaging, storing, and using the existing topsoil removed from active construction areas to enhance final site stabilization, infiltration and vegetation.
- B. Applicability – Top Soiling shall be considered as a cost effective measure on construction sites where there is a sufficient supply of quality topsoil that will be excavated during construction activities.
- C. Design – Determine whether the quality and quantity of available topsoil justifies selective handling. Quality topsoil has the following characteristics:
1. Texture – loam, sandy loam, and silt loam are best; sandy clay loam, silty clay loam, clay loam, and loamy sand are fair. Do not use heavy clay and organic soils such as peat or muck as topsoil.
  2. Organic matter content – (sometimes referred to as “humic matter”) shall be greater than 1.0% by weight, but never more than 30% of total content.
  3. Acidity – pH should be greater than 3.6 before liming as required if the pH is less than 6.0.

Follow these Guidelines for Selective Handling of Top Soil:

1. Stripping – Strip topsoil only from those areas that will be disturbed by excavation, filling, road building, or compaction. Stripping depth shall be from 4-6 in. (102-152 mm) depending on the site. Put sediment basins, diversions, and other controls into place before stripping.
  2. Stockpiling – Select stockpile location to avoid slopes and natural drainage ways, and to avoid traffic routes. On large sites, re-spreading is easier and more economical when topsoil is stockpiled in small piles located near areas where they will be used.
  3. Sediment Barriers – Use silt fences or other barriers where necessary to retain sediment.
  4. Scheduling – Follow the Construction Sequence Schedule for spreading the salvaged topsoil as soon as their permanent location is ready. Placing and stabilizing slopes and landscaped areas as construction progresses reduces runoff sedimentation and erosion and is cost effective as it reduces the use of more costly BMP's.
  5. Spreading Topsoil – Uniformly distribute topsoil to a minimum compacted depth of 2 in (51 mm) on no greater than a 3:1 (H:V) slopes and 4 in (102 mm) on flatter slopes.
- D. Maintenance – Where salvaged topsoil is to be stockpiled for more than 30 days protect it with temporary seeding as soon as possible. Use annual rye grass, winter wheat, or other fast-growing cover crop that will not become a problem plant. If the salvaged topsoil will be stockpiled for up to 12 months permanent vegetation shall be used to control erosion and weed growth. Sediment barriers shall be inspected and maintained throughout the time salvaged topsoil is stockpiled.

#### ***11-4.5 Preservation of Existing Vegetation***

- A. Definition – The planned preservation of existing stable vegetated areas to reduce soil erosion and the amount of sediment in runoff water and to minimize the extent of disturbed area.
- B. Applicability – Sections of existing trees, shrubs, vines and grassy areas shall be preserved when existing vegetated area can be integrated into the proposed project on a temporary or permanent bases. Examples where preserving existing vegetation shall be applicable include, but not limited to:
1. Buffer strips adjacent to wetlands and other sensitive areas.
  2. As perimeter protection along property lines.

3. Undeveloped portions of a job site.
  4. Areas covered under local, state and federal government protection such as vernal pools, wetlands, marshes, riparian habitat, and certain oak trees, etc.
  5. Vegetated areas designated for later removal that can be utilized temporarily for erosion control.
- C. Design
1. Areas of vegetation to be preserved shall be clearly marked on Plans and fenced or flagged in the field.
  2. Traffic and stockpiles shall be located away from vegetated areas. Any needed irrigation and maintenance shall be specified on the Plans.
  3. For appropriate widths of vegetated area, refer to the specifications for Hydroseeding (Section 11-4.6).
- D. Maintenance – Irrigation and maintenance requirements shall be specified on the Plans. Irrigation shall be provided as needed to maintain the vegetation year round.

#### ***11-4.6 Hydroseeding***

- A. Definition – The application of a mixture of fiber and stabilizing emulsion, with seed, and with fertilizer using hydro-mulch equipment, which temporarily protects exposed soils from erosion by wind and water.
- B. Applicability – Hydroseeding shall be applied under the following conditions:
1. Graded or cleared areas subject to erosion from wind or water.
  2. Disturbed area that will not have permanent stabilization.
  3. Install hydroseeding in 20-foot wide buffer strips at the back of walk or back of curb where sidewalks are detached or omitted, or to the top of slope at the pad.
  4. Hydroseeding as perimeter control along property lines where established vegetation does not exist.
  5. If slopes to be hydroseeded are steeper than 3:1 (H:V), hydroseeding shall be used in combination with matting, mulching, hydraulic mulching, or other soil stabilizer.
- C. Design – Areas to be hydroseeded shall be clearly identified on the Plans.
- Application shall conform to the following:
1. Timing – Hydroseeding shall be implemented in advance of the time when there is risk of erosion. To protect areas by October 1, hydroseeding shall be implemented no later than September 15. Hydroseeding applied after October 1 and before April 30 shall be covered with straw mulch, soil binder, or erosion control blanket/mat.
  2. Adjacent to wetlands and environmentally sensitive areas, the minimum width of a vegetated area draining into the affected area shall be 100 feet for slopes of 20:1 (H:V) or flatter. When slopes are steeper than 20:1 (H:V), additional measures shall be used as determined by the County Engineer. Adjacent to improvements, the minimum width shall be 20 feet.
- D. Maintenance
1. All slopes shall be maintained to prevent erosion.
  2. Seeded areas shall be inspected for failures and re-seeded, fertilized, and mulched within the planting season. Any temporary re-vegetation efforts that do not provide adequate cover must be re-vegetated as required by the County Engineer.

#### ***11-4.7 Soil Binders***

- A. Definition – The application and maintenance of polymeric or lignin sulfonate stabilizers or emulsions. Soil binders are materials applied to the soil surface to temporarily prevent wind or water-induced erosion of exposed soils.
- B. Applicability – Soil binders are applied to disturbed areas requiring short-term temporary protection.

C. Design

1. Soil binders are temporary in nature and may need reapplication.
2. Soil binders shall be applied a minimum of 24 hours prior to a rainfall event. Application during or immediately prior to rainfall will not be permitted.
3. Soil binders shall be environmentally friendly (non-toxic to plant and animal life) and shall not stain or discolor paved or painted surfaces.
4. Selection and application of soil binders shall be in accordance with the manufacturer's recommendations and specifications.

**11-4.8 Stabilized Construction Access**

A stabilized construction site access is not required at sites where public streets or roads are unpaved.

- A. Definition – A stabilized access consisting of a pad of course aggregate underlain with filter cloth located where traffic enters or leaves a construction site to minimize a tracking of sediment from a construction site onto paved streets.
- B. Applicability – A stabilized construction access shall be applied at the following location where construction traffic enters or leaves:
1. Paved public streets, sidewalks and rights-of-way.
  2. Parking lots or other paved areas.
- C. Design
1. Placement of stabilized construction access shall be clearly defined on the Improvement Plans.
  2. The stabilized construction site access shall be constructed per Standard Drawing 11-1.
  3. This practice shall be supported by a tire wash area and street sweeping or vacuuming. The County Engineer may require a tire wash area where site conditions necessitate BMP measures beyond the stabilized construction access.
- D. Maintenance – Inspect stabilized construction access daily for damage and effectiveness of preventing soil, sediment, and construction debris from being tracked onto public streets. Streets adjacent to stabilized construction access shall be swept or vacuumed daily to remove loose materials.

**11-4.9 Sediment Trap**

- A. Definition – A small temporary basin formed by excavation to intercept and detain the sediment-laden runoff to allow the sediment to settle. It is used to protect other drainage facilities and properties downstream of the sediment trap.
- B. Applicability – There are two types of sediment traps:
1. Vegetated outlet traps suitable for drainage areas of less than 5 acres.
  2. Stabilized outlet traps, suitable for drainage areas from 5 to 10 acres.

Sediment traps shall **not** be applied under the following conditions:

1. The drainage area is greater than 10 acres.
  2. In a creek or stream.
  3. Uphill from a street or utility trench.
  4. In areas subject to trespass.
- C. Design
1. Placement of a sediment trap shall be clearly defined on the Plans.
  2. Sediment traps shall be constructed as the first step when there is mass clearing or grading and shall be located at the point where drainage discharges from a site.
  3. Construction of sediment traps shall be per Standard Drawing 11-2.
  4. The sediment trap storage volume shall be designed for 35 cubic yards per acre of contributing drainage area.



5. Side slopes shall be 3:1 (H:V) or flatter and the maximum depth shall be 3.5 feet .
6. The length of a sediment trap shall be 2 times (minimum) its width.

D. Maintenance

1. Trap maintenance shall be year round. Sediment material shall be removed from the bottom to retain one foot of capacity at all times.
2. Trap slopes shall be kept in good repair. Slope failures or damage shall be repaired promptly.

**11-4.10 Sediment Basin**

- A. Definition – A temporary basin formed by excavation to intercept and detain sediment-laden runoff to allow the sediment to settle. It is used to protect other drainage facilities and properties downstream of the sediment basin.
- B. Applicability – Sediment basins are suitable for incorporating into the construction of permanent facilities designed for flood control and water quality.

Sediment basins shall **not** be applied under the following conditions:

1. In a creek or stream.
2. Where the project site can be broken up into small drainage areas (10 acres or less) where sediment traps can be used.
3. Where failure can cause property damage or loss of life.
4. In areas subject to trespass unless they are secured.

- C. Design – Basins shall be located, sized and configured based on site-specific conditions. All basin designs are subject to approval by the County Engineer. In addition to County Standards the sediment basins shall meet the minimum requirements of the State’s General Construction Permit.

1. Basin sizing shall be in accordance with one of the three (3) options below:
  - a. Sediment basin(s), as measured from the bottom of the basin to the principal outlet, shall have at least a capacity equivalent to 133 cubic yards of storage per acre draining into the sediment basin. The length of the basin shall be more than twice the width of the basin. The length is determined by measuring the distance between the inlet and outlet, and the depth must not be less than 3 feet nor greater than 5 feet for safety reasons and for maximum efficiency.
  - b. Sediment basin(s) shall be designed using the methodologies specified in Section 9-8 or the standard equation:

$$A_s = 1.2 Q/V_s$$

Where:  $A_s$  is the minimum surface area for trapping soil particles of a certain size;  $V_s$  is the settling velocity of the design particle size chosen; and  $Q = C \times I \times A$  where  $Q$  is the discharge rate measured in cubic feet per second;  $C$  is the runoff coefficient;  $I$  is the intensity for the 10-year, 6-hour rain event and  $A$  is the area draining into the sediment basin in acres. The design particle size shall be the smallest soil grain size determined by wet sieve analysis, or the fine silt size (0.01 mm) particle, and the  $V_s$  used shall be 100 percent of the calculated settling velocity.

The length is determined by measuring the distance between the inlet and the outlet; the length shall be more than twice the dimension as the width; the depth shall not be less than 3 feet nor greater than 5 feet for safety reasons and for maximum efficiency (2 feet of storage, 2 feet of capacity). The basin(s) shall be located on the site where it can be maintained on a year round basis and shall be maintained on a schedule to retain the 2 feet of capacity.

- c. The use of an equivalent surface area design or equation, provided that the design efficiency is as protective of water quality than option b.
2. Construction of sediment basins shall be per Standard Drawing 11-3.

3. The County Engineer shall approve all Basins for drainage areas larger than 75 acres (30 hectares).
4. Sediment basins shall be fenced where safety (worker or public) is a concern, or as indicated by the County Engineer.

D. Maintenance

1. Basin maintenance shall be year round. Sediment material shall be removed from the bottom to retain 2 feet of capacity at all times.
2. Basin slopes shall be kept in good repair. Slope failures or damage shall be repaired promptly.
3. Basins shall have a means for dewatering within 7-calendar days follow a storm event.

**11-4.11 Geotextiles, Mats, and Erosion Control Blankets**

A. Definition – The placement of natural or synthetic geotextiles, plastic covers, or erosion control blanket/mats on the soil surface to stabilize disturbed areas and protect soils from erosion from wind, rain and water runoff. They may also be used to assist in the establishment of vegetation.

B. Applicability

1. Use these surface applications in conjunction with hydroseeding (Section 11-7) where slopes exceed 3:1 (H:V) or on exposed slopes when the timing is too late in the year for planting.
2. Use when disturbed soils may be difficult to stabilize with other BMP's.
3. Use as cover material and to protect soil stockpiles during rainfall events.
4. Use on channels to be vegetated.

Geotextiles, Mats, and Erosion Control Blankets shall **not** be applied in the following circumstances:

1. On excessively rocky sites.
2. For use with final phase vegetation if the vegetation is to be mowed.

C. Design – Areas where geotextiles, erosion blankets and matting are to be used shall be uniquely defined on the Plans.

1. Installation shall be in accordance with the manufacturers recommendation.
2. Geotextile material shall be woven polypropylene fabric with minimum thickness of 0.6 in (15 mm), minimum width of 12 feet and shall have a minimum tensile strength of 0.67 kN (warp) and 0.36 kN (fill) in conformance with the requirements of ASTM Designation: D4632. The permittivity of the fabric shall be approximately  $0.07 \text{ sec}^{-1}$  in conformance with the requirements in ASTM Designation: D4491. The fabric shall have an ultraviolet (UV) stability of 70 percent in conformance with the requirements in ASTM Designation: D4355.
3. Geotextile blankets/mats shall be secured in place with wire staples or sandbags and by keying into tops of slopes to prevent infiltration of surface waters under geotextile material.
4. Plastic cover material shall be polyethylene sheeting and shall have a minimum thickness of 6 mils. Plastic covers shall be anchored by sandbags placed no more that 10 feet apart and by keying into the tops of slopes to prevent infiltration of surface waters under the plastic. All seams shall be taped or weighted down their entire length, and there shall be as least a 12 in (300 mm) to 24 in (600 mm) overlap of all seams.
5. Erosion control blankets/mats shall be made of either straw, coconut, straw/coconut or excelsior blanket. Grade and shape the area of installation. Remove all rocks, clods, vegetation or other obstructions so that the installed blankets or mats will have complete, direct contact with the soil. Blankets/mats shall be anchored with U-shaped wire staples, metal geotextile stake pins or triangular wooden stakes. Staples shall be made of 0.12 in (3.05 mm) steel wire and shall be U-shaped with 7.9 in (200 mm) legs and a 2 in (50 mm) crown. Wire staples shall be minimum of 11 gauge. Metal stake pins shall be 0.2 in (5 mm) diameter steel with a 1.5 in (40 mm) steel washer at the head of the pin. Wire staples and metal pins shall be driven flush to the soil surface. All anchors shall be 6 in (150 mm) to 18 in (450 mm) long and have sufficient ground penetration to resist pullout.

6. Channels constructed during the wet season (October 1 through April 30) shall have the channel sides and bottom protected with erosion control blankets/mats as shown in Standard Drawing 11-4.
7. Channel bottoms shall be protected where the design channel flow exceeds 3 feet/sec.

D. Maintenance

1. All blankets shall be inspected periodically after installation.
2. Inspect installations after significant rainfalls to check for erosion and undermining. Repair failures immediately. Damage to slopes or channels shall be repaired prior to reinstalling blankets/mats.

**11-4.12 Silt Fence**

- A. Definition – A barrier of extra strength filter fabric that has been entrenched and attached to supporting posts to reduce runoff velocity and detain sediment.
- B. Applicability – Silt fences are used near disturbed areas where sheet or rill flows occur and velocities are low. Silt fences are placed below the toe of exposed and erodible slopes, down-slope of exposed soil areas, around temporary stockpiles and along streams and channels.

Silt fences shall **not** be applied under the following conditions:

1. In the flowline of streams, channels, or anywhere flows are concentrated.
2. Drainage area of 1 acre or more.
3. Where the slope is steeper than 2:1 (H:V).
4. Slopes that are subject to creep, slumping, or landslides.
5. Mid-slope installations where slope exceeds 4:1 (H:V).

C. Design

1. Placement of silt fences shall be clearly shown on the Plans.
2. Construction shall be per Standard Drawing 11-5.
3. The maximum slope length above the fence shall be no more than 30 feet times the slope steepness expressed as a ratio. For example, a 4:1 (H:V) slope above a fence shall be no more than 120 feet. The maximum slope distance between silt fences, regardless of slope, shall be 200 feet.
4. The depth of flow shall be evenly distributed across the fence.
5. Silt fences shall be trenched in and the bottom of the fence fabric shall be keyed in.
6. The fence shall be placed on the contour and configured in the shape of a shallow arc with the ends uphill of the arc's center. It shall be constructed in a length sufficient to extend across the expected flow path.

D. Maintenance

1. Repair or replace split, torn, slumping or weathered fabric.
2. Inspect silt fences when rain is forecast and again after a rainfall event.
3. Sediment shall be removed from behind the silt fence when sediment accumulation is 1/3 the height of the barrier or when sediment accumulation is causing the silt fence to fail.

**11-4.13 Straw Bale Barrier**

- A. Definition – A barrier constructed with straw or hay bales across or at the toe of a slope to reduce runoff velocity and transport of sediment.
- B. Applicability

Straw bale barriers shall **not** be applied in the following conditions:

1. Where concentrated flows occur.
2. On slopes steeper than 2:1 (H:V).

C. Design

1. Placement of straw bale barriers shall be clearly defined on the Plans.
2. Construction shall be per Standard Drawing 11-6.

3. The maximum slope length above the barrier shall be no more than 30 feet times the steepness expressed as a ratio. For example, the length of a 3:1 (H:V) slope above a barrier shall be no more than 90 feet. Bales shall be securely staked.
4. The depth of flow shall be evenly distributed across the barrier.
5. The barrier shall be placed on the contour and configured in the shape of a shallow arc with the ends uphill of the arc's center. It shall be constructed in a length sufficient to extend across the expected flow path.
6. Provision shall be made for an overflow in the event that the bales act as a dam and do not filter and disperse the flow.
7. For habitat restoration projects, or at other sensitive locations, the County may require that straw bales be manufactured from rice straw or native grasses.

#### ***11-4.14 Inlet Sediment Control Barriers and Filters***

- A. Definition – A temporary sediment barrier placed in the gutter adjacent to, around, or suspended within a storm drain inlet to prevent sediment and debris from entering the storm drainage system.
- B. Applicability – Drop inlet protection is applicable after storm drain systems are installed. Inlet filter bags or inlet filters shall be installed at all drop inlets on new or existing streets within or downstream of the construction site.
- C. Design
  1. Sediment control devices shall be designed to allow maintenance of the device and regular removal of trapped sediments.
  2. Within traveled ways, vehicular and pedestrian, devices shall be selected and installed so that they do not constitute a hazard.
  3. Inlet sediment control devices may consist of gravel bags or other approved sediment control device, which provides effective sediment removal.
  4. Install per Standard Drawing 11-7.
  5. Inlet sediment control devices shall remain in place until soil-disturbing activities are completed and adjacent areas are stabilized.
- D. Maintenance
  1. Inlet sediment control devices shall be kept in good repair. Material spilling from sediment control devices shall be cleaned up and the device repaired or replaced immediately.
  2. Inspection of devices shall be weekly and prior to predicted rainfall and after a rainfall event. Sediment removed from sediment control devices during maintenance operations shall be disposed of properly.
  3. Trapped sediment and debris shall be removed from the inlet filter bag after each rainfall event.
  4. Inlet filter bags having visible trapped water shall be maintained immediately.
  5. Torn filter bags shall be removed and replaced.
  6. Filter bags and frames shall be placed such that low flow surface water does not bypass the filter bag.

#### ***11-4.15 Straw Mulch and Hydraulic Mulching***

- A. Definition – Placing a uniform layer of straw mulch and incorporating it into the soil with a studded roller or anchoring it with a tackifier. Or using a mixture of shredded wood fiber or a hydraulic matrix and a stabilizing emulsion or tackifier and spreading it by hydro-mulching equipment.

- B. Applicability – Straw mulch is used for temporary soil stabilization on disturbed areas until soils can be prepared for re-vegetation and permanent vegetation is established. Straw mulch is also used in temporary and permanent seeding strategies to enhance plant establishment.
- C. Design
1. Straw shall be derived from wheat, rice, or barley, and be free of noxious weed seeds.
  2. Straw mulch with tackifier shall not be applied during or immediately prior to rainfall.
  3. Tackifier is the preferred method for anchoring straw mulch to the soil on slopes. Crimping, punch roller-type rollers, or tack-walking may also be used.
  4. Apply loose straw at a minimum rate of 4,000 lb/ac (3,570 kg/ha).
  5. Apply tackifier at a minimum rate of 125 lb/ac (140 kg/ha).
  6. Areas to be covered using hydraulic mulching must be roughened using a rolling crimping or punching type roller or by track walking. Track walking shall only be used where other methods are impractical.
  7. Wood fiber mulch can be applied alone at the rate of 2,000 to 4,000 lbs/ac (1,785 to 3,570 kg/ha) or as a component of hydraulic matrices.
  8. Hydraulic matrices include a mixture of wood fiber and acrylic polymer or other tackifier as a binder and applied as a liquid slurry using a hydraulic application equipment. The minimum rate of application shall be follow manufacturer's specification to achieve complete coverage of 2,000 to 4,000 lbs/ac (1,785 to 3,570 kg/ha), and 5 to 10% (by weight) of tackifier (acrylic copolymer, guar, psyllium, etc.).
  9. Hydraulic matrices application requires 24 hours to dry before a rainfall event.
- D. Maintenance
1. Maintain an unbroken temporary mulched ground cover throughout the period of construction when the soils are not being reworked.
  2. Reapplication of straw mulch and tackifier may be required by the County Engineer to maintain effective soil stabilization over disturbed areas and slopes.
  3. Slopes shall be maintained and repaired immediately after any rainfall event.

#### ***11-4.16 Fiber Rolls***

- A. Definition – A fiber roll consists of straw, flax, or other materials that are rolled and bound into a tight tubular roll and placed on the face of slopes at regular intervals or behind curbs and walkways to intercept storm water runoff, reduce its velocity, release the runoff as sheet flow, and provide some removal of sediment from the runoff.
- B. Applicability – Fiber rolls shall be used along the top, face and at grade breaks of exposed and erodible slopes, placed behind curbs or walkways, and used as check dams when properly anchored.
- C. Design
1. On slopes fiber rolls shall be placed along the contour. At the ends of the row, the last 2 feet shall be turned up slope slightly.
  2. Fiber rolls shall be manufactured and have a minimum density of 1.1 lbs/lf (1/6 kg/m). Use and installation of fiber rolls shall be in accordance with the manufacturer's recommendations.
  3. When more than one fiber roll is placed in a row, the ends of the rolls shall be butted together tightly, or overlapped a minimum of 1 foot.
  4. Fiber rolls used as check dams shall be trenched and staked such that water is not allowed to flow under the rolls.
  5. Install per Standard Drawing 11-8.
  6. For habitat restoration projects, or at other sensitive locations, the County may require that fiber rolls be manufactured from rice straw or native grasses.

**D. Maintenance**

1. Repair or replace split, torn, unraveling, or slumping fiber rolls.
2. Inspect fiber rolls when rain is forecast.
3. In active construction areas where fiber rolls are removed during the workday, return or replace the fiber rolls to its proper place and stake them down at the end of each workday during the wet season.

**11-4.17 Concrete Washouts**

- A. Definition – Procedures and practices that are implemented to minimize or eliminate the discharge of concrete waste materials to the storm drain system or to watercourses.
- B. Applicability – Concrete washouts are to be placed on project sites where concrete is used as a construction material, where slurries containing Portland cement concrete (PCC) or asphalt concrete are generated, or where concrete trucks and other concrete-coated equipment are washed on site.
- C. Design
  1. Temporary concrete washout facilities shall be located a minimum of 50 feet from storm drain inlets, open drainage facilities, and watercourses.
  2. A sign shall be installed adjacent to each washout facility to inform concrete equipment operators of its location. Signs shall be placed on construction sites providing direction to the concrete washout.
  3. Installation shall be per Standard Drawing 11- 9.
  4. Plastic lining material shall be a minimum of 60 mils polyethylene sheeting and shall be free of holes, tears or other defects that compromise the impermeability of the material.
  5. Concrete washouts constructed below grade shall have a minimum depth of 12 in (0.30 m) and have a surface area of 50 square feet (4.645 square meters).
- D. Maintenance
  1. Inspect concrete washouts daily.
  2. Concrete washouts shall be cleaned when the waste volume in the washout reaches 75% of capacity.

**11-4.18 Clean Up**

All temporary erosion and sediment control measures shall be cleaned up and removed by the Contractor upon completion of all improvements and after establishment of all permanent erosion and sediment control measures and/or permanent landscaping. As a portion of the temporary erosion and sediment control measures are no longer needed, they shall be cleaned up and removed from the project site. Any organic matter, such as partially decomposed straw bales, may be spread as mulch in landscaped areas at the discretion of the property owner. Any non-organic matter shall be removed from the project site and disposed of at a landfill or other recycling facility or hazardous material disposal center, as appropriate. Street washing is not allowed, as is sends tracked sediment down the storm drains or receiving waters.

**11-4.19 Street Sweeping and Vacuuming**

- A. Definition – Street sweeping and vacuuming includes use of self-propelled and walk-behind equipment to remove sediment from streets and roadways, and to clean paved surfaces in preparation for final paving. Sweeping and vacuuming prevents sediment from the project site that has been tracked onto the street surface from entering storm drains or receiving waters.
- B. Applicability – Sweeping and vacuuming are suitable anywhere sediment is tracked from the project site onto public or private paved streets and roads, typically at points of egress.
- C. Design

1. Limit the number of points where vehicles can leave the project site to focus sweeping and vacuuming efforts.
2. Inspect potential sediment tracking locations daily.
3. Visible sediment tracking shall be swept or vacuumed on a daily basis.
4. Do not use kick brooms or sweeper attachments. These tend to spread the dirt rather than remove it.
5. If the removed sediment swept or vacuumed up is not mixed with debris or trash it may be incorporated back into the project at the owner's discretion.
6. If tracked sediment is wet or caked on the paved surface it will need to be scraped loose prior to sweeping or vacuuming.

D. Maintenance

1. Inspect BMP's prior to forecast rain, daily during extended rain events, after rain events, weekly during the rainy season, and at two-week intervals during the not-rainy season for sources of potential sediment tracking.
2. When actively in use, points of ingress and egress must be inspected daily.
3. When tracked or spilled sediment is observed outside the construction limits, it must be removed daily. Tracked sediment removal shall be removed continuously during rain events if construction activities are being pursued.
4. Be careful not to sweep up any unknown substance or any object that may be potentially hazardous.
5. Adjust brooms frequently to maximize efficiency of sweeping operations.
6. After sweeping is finished, properly dispose of sweeper wastes at an approved dumpsite.

## **11-5 PERMANENT POST-CONSTRUCTION STORMWATER POLLUTION CONTROLS FOR NEW DEVELOPMENT OR REDEVELOPMENT PROJECTS**

### ***11-5.1 Project Categories Subject to these Design Standards:***

All discretionary development or redevelopment projects that fall into one of the following categories are subject to these Improvement Standards. These categories are:

1. Single-family hillside residences
2. 100,000 square foot commercial developments
3. Automotive repair shops & automobile dismantling
4. Retail gasoline outlets
5. Restaurants
6. Home subdivisions occupying an acre or more
7. Parking lots 5,000 square feet or more or with 25 or more parking spaces and potentially exposed to storm water runoff

### ***11-5.2 Design Standards Applicable to all Categories***

#### **11-5.2.1 Maintain Pre-Development Peak Stormwater Discharge Rates**

Post-development peak storm water runoff discharge rates shall not exceed the estimated pre-development rate for developments where the increased peak storm water discharge rate will result in increased potential for downstream erosion.

#### **11-5.2.2 Conserve Natural Areas**

If applicable, the following items are required and must be implemented in the site layout during the subdivision design and approval process, consistent with applicable County General Plan policies:

1. Concentrate or cluster Development on portions of a site while leaving the remaining land in a natural undisturbed condition.

2. Limit clearing and grading of native vegetation at a site to the minimum amount needed to build lots, allow access, and provide fire protection.
3. Maximize trees and other vegetation at each site by planting additional vegetation, clustering tree areas, and promoting the use of native and/or drought tolerant plants.
4. Promote natural vegetation by using parking lot islands and other landscaped areas.
5. Preserve riparian areas and wetlands.
6. Preserve oaks, singular specimen native plants and other vegetation that is determined to be significant to the site or habitat associated with the area, as determined by the County.

#### 11-5.2.3 Minimize Stormwater Pollutants of Concern

Pollutants of concern consist of any pollutants that exhibit one or more of the following characteristics: current loadings or historic deposits of the pollutant are impacting the beneficial uses of a receiving water, elevated levels of the pollutant are found in sediments of a receiving water and/or have the potential to bioaccumulate in organisms therein, or the detectable inputs of the pollutant are not at concentrations or loads considered potentially toxic to humans and/or flora and fauna.

1. Oil and Grease
2. Suspended Solids and Metals
3. Gasoline
4. Antifreeze
5. Pesticides
6. Pathogens

#### 11-5.2.4 Protect Slopes and Channels

Project plans must include BMPs consistent with Yolo County codes and Ordinances, and other regulatory mechanisms and these Improvement Standards aimed at decreasing the potential of slopes and/or channels from eroding and impacting stormwater runoff:

1. Convey runoff safely from the tops of slopes and stabilize disturbed slopes.
2. Utilize natural drainage systems to the maximum extent practicable.
3. Stabilize permanent channel crossings.
4. Vegetate slopes with native or drought tolerant vegetation, as appropriate.
5. Install energy dissipaters, such as riprap, where appropriate to minimize erosion, with the approval of all agencies with jurisdiction, e.g., the U.S. Army Corps of Engineers and the California Department of Fish and Game.

#### 11-5.2.5 Concrete Storm Drain System Stamp or Epoxied Placards

Developers shall install NPDES labeled cast iron drain inlet covers standard storm drain stencils or signs at the public access points to storm drain, channels, creeks, or other watercourses within the project area as described under the following specification

- A. Definition – A message stamped into the concrete or cast into any cast iron framework at each storm drain drop inlet to alert citizens not to dump into the storm drainage system. Or in the case of a storm drain drop inlet retro-fit project a placard containing the same message epoxied to the top of the drop inlet.
- B. Applicability – Concrete stamps or NPDES drain inlet covers shall be used at all new or reconstructed storm drain inlets. Placards shall be applied to retrofitted storm drain inlets as required.
- C. Design
  1. The County Engineer shall approve all concrete stamps and placards before being installed.



2. Concrete stamps shall be installed at grated inlets as shown on Standard Drawing 11-10. Cast iron cover with NPDES logo shall be installed on curb face style inlets as shown on Standard Drawing 9-5

#### 11-5.2.6 Outdoor Material Storage Areas

Outdoor material storage areas refer to storage areas or storage facilities solely for the storage of materials. Improper storage of materials outdoors may provide an opportunity for toxic compounds, oil and grease, heavy metals, nutrients, suspended solids, and other pollutants to enter the storm water conveyance system or other watercourses. Where proposed project plans include outdoor areas for storage of materials that may contribute pollutants to the storm water conveyance system or watercourses, the following Structural or Treatment Control BMPs are required:

1. Materials with the potential to contaminate stormwater must be: 1) placed in an enclosure such as, but not limited to, a cabinet, shed, or similar structure that prevents contact with storm water runoff or spillage to the stormwater conveyance system or watercourses; or 2) protected by secondary containment structures such as berms, dikes, or curbs.
2. The storage area must be paved and sufficiently impervious to contain leaks and spills.
3. The storage area must have a roof or awning to minimize collection of stormwater within the secondary containment area.

#### 11-5.2.7 Trash Storage Areas

A trash storage area refers to an area where a trash receptacle or receptacles (dumpsters) are located for use as a repository for solid wastes. The forces of water or wind can easily transport loose trash and debris into nearby storm drain inlets, channels, and other watercourses. All trash container areas must meet the following Structural and Treatment Control BMP requirements (individual single family residences are exempt from these requirements):

1. Trash container areas must be covered and have drainage from adjoining roofs and pavement diverted around the area(s).
2. Trash container areas must be screened or walled to prevent off-site transport of trash.

#### 11-5.2.8 Ongoing BMP Maintenance

As a part of a project review, if a project applicant has included or is required to include, Structural or Treatment Control BMPs in project plans, it is required that the applicant provide verification of maintenance provisions through such means as may be appropriate, including, but not limited to legal agreements, covenants, CEQA mitigation requirements and /or Conditional Use Permits.

For all properties, the verification will include the Developer's signed statement, as part of the project application, accepting responsibility for all Structural and Treatment Control BMP maintenance until the time the property is transferred and , where applicable, a signed agreement from the public entity assuming responsibility for Structural or Treatment Control BMP maintenance. The transfer of property to a private or public owner must have conditions requiring the recipient to assume responsibility for maintenance of any Structural or Treatment Control BMPs to be included in the sales or lease agreement for that property, and will be the owner's responsibility. The condition of transfer shall include a provision that the property owners conduct maintenance inspection of all Structural or Treatment Control BMPs at least once a year and retain proof of inspection. For residential properties where the Structural or Treatment Control BMPs are located within a common area, which will be maintained by a homeowner's association, language regarding the responsibility for maintenance must be included in the project's conditions, covenants and restrictions (CC & Rs). Printed educational materials will be required to accompany the first deed transfer to highlight the existence of the requirement and to provide the first deed transfer to highlight the existence of the

requirement and to provide information on what storm water management facilities are present, signs that maintenance is needed, how the necessary maintenance can be preformed, and assistance that the County can provide. The transfer of this information shall also be required with any subsequent sale of the property.

If Structural or Treatment Control BMPs are located within a public area proposed for transfer, they will be the responsibility of the Developer until they are accepted for transfer by the County or other appropriate public agency. Structural or Treatment Control BMPs proposed for transfer must meet design standards adopted by the public entity for the BMP installed and should be approved by the County or other appropriate public agency prior to its installation.

#### 11-5.2.9 Structural or Treatment Control BMPs

Yolo County requires that post-construction Treatment Control BMPs incorporate, at minimum, either a volumetric or flow based treatment control design standard, or both, as identified below to mitigate (infiltrate, filter or treat) storm water runoff:

1. Volumetric Treatment Control BMP
  - a. The 85<sup>th</sup> percentile 24-hour runoff event determined as the maximized capture storm water volume for the area, from the formula recommended in Urban Runoff Quality Management, WEF Manual of Practice No. 23/ASCE Manual of Practice No. 87, (1998); or
  - b. The volume of annual runoff based on unit basin storage water quality volume, to achieve 80 percent or more volume treatment by the method recommended in California Stormwater Best Management Practices Handbook – Industrial/Commercial, (2003); or
  - c. The volume of runoff produced from a historical-record based reference 24-hour rainfall criterion for “treatment” that achieves approximately the same reduction in pollutant loads achieved by the 85<sup>th</sup> percentile 24-hour runoff event.
2. Flow Based Treatment Control BMP
  - a. The flow of runoff produced from a rain event equal to at least two times the 85<sup>th</sup> percentile hourly rainfall intensity for the area; or
  - b. The flow of runoff produced from a rain event that will result in treatment of the same portion of runoff as treated using the volumetric standards above.

Limited Exclusion:

Restaurants and Retail Gasoline Outlets, where the land area for development or redevelopment is less than 5,000 square feet, are excluded from the numerical Structural or Treatment Control BMP design standard requirement only.

### ***11-5.3 Design Standards Applicable to Individual Priority Project Categories***

#### 11-5.3.1 100,000 Square Foot Commercial Developments

##### 1. Properly Design Loading/Unloading Dock Areas

Loading/Unloading dock areas have the potential for material spills to be quickly transported to the stormwater conveyance system or watercourses. To minimize this potential, the following design criteria are required:

- a. Cover loading dock areas or design drainage to minimize run-on and runoff of stormwater.
- b. Direct connections to storm drains from depressed loading docks (truck wells) are prohibited.

##### 2. Properly Design Repair/Maintenance Bays

Oil and grease, solvents, car battery acid, coolant and gasoline from repair/maintenance bays can negatively impact stormwater if allowed to come into contact with stormwater runoff. Therefore, design plans for repair bays must include the following:

- a. Repair/maintenance bays must be indoors or designed in such a way that doesn't allow stormwater run-on or contact with stormwater runoff.
- b. Design a repair/maintenance bay drainage system to capture all wash-water, leaks and spills. Connect drains to a sump for collection and disposal. Direct connection of the repair/maintenance bays to the storm drain system is prohibited.

### 3. Properly Design Vehicle/Equipment Wash Areas

The activity of vehicle/equipment washing/steam-cleaning has the potential to contribute metals, oil and grease, solvents, phosphates, and suspended solids to the stormwater conveyance system or watercourses. Include in the project plans an area for washing/steam-cleaning of vehicles and equipment. The area in the site design must be:

- a. Self-contained, equipped with grease trap, and properly connected to a sanitary sewer.
- b. If the wash area is to be located outdoors, it must be covered, paved, have secondary containment, and be connected to the sanitary sewer or other appropriately permitted disposal facility.

### 11-5.3.2 Restaurants

#### 1. Properly Design Equipment/Accessory Wash Areas

The activity of outdoor equipment/accessory washing/steam-cleaning has the potential to contribute metals, oil and grease, solvents, phosphates, and suspended solids to the stormwater conveyance system or watercourses. Include in the project plans an area for the washing/steam-cleaning of equipment and accessories. This area must be:

- a. Self-contained, equipped with a grease trap, and properly connected to a sanitary sewer.
- b. If the wash area is to be located outdoors, it must be covered, paved, have secondary containment, and be connected to the sanitary sewer or other appropriately permitted disposal facility.

### 11-5.3.3 Retail Gasoline Outlets

#### 1. Properly Design Fueling Area

Fueling areas have the potential to contribute oil and grease, solvents, car battery acid, coolant and gasoline to the stormwater conveyance system or watercourse. The project plans must include the following BMPs:

- a. The fuel dispensing area must be covered with an overhanging roof structure or canopy. The canopy's minimum dimensions must be equal to or greater than the area within the grade break. The canopy must not drain onto the fuel dispensing area, and the canopy downspouts must be routed to prevent drainage across the fueling area.
- b. The fuel dispensing area must be paved with Portland cement concrete (or equivalent smooth impervious surface), and the use of asphalt concrete shall be prohibited.
- c. The fuel dispensing area must have a 2% slope to prevent ponding, and must be separated from the rest of the site by a grade break that prevents run-on of stormwater to the extent practicable.
- d. At a minimum, the concrete fuel dispensing area must extend 6.5 feet (2.0 meters) from the corner of each fuel dispenser, or the length at which the hose and nozzle assembly may be operated plus 1 foot (0.3 meter), whichever is less.
- e. The site shall be graded in a manner that prevents untreated stormwater from being discharged directly to the public stormwater conveyance system or watercourse.
- f. The site shall be graded in a manner that provides onsite storage for that volume of stormwater which the parcel generates in the 10-year, 2 hour event, to ensure stormwater is captured and treated.
- g. Stormwater discharges shall be treated to remove hydrocarbons and other contaminants prior to being discharged to the stormwater conveyance system or watercourse.

#### 11-5.3.4 Automotive Repair Shops & Automobile Dismantling

##### 1. Properly Design Fueling Area

Fueling areas have the potential to contribute oil and grease, solvents, car battery acid, coolant and gasoline to the stormwater conveyance system and watercourses. Therefore, design plans, which include fueling areas, must contain the following BMPs:

- a. The fuel dispensing area must be covered with an overhanging roof structure of canopy. The canopy's minimum dimensions must be equal to or greater than the area within the grade break. The canopy must not drain onto the fuel dispensing area, and the canopy downspouts must be routed to prevent drainage across the fueling area.
- b. The fuel dispensing area must be paved with Portland cement concrete (or equivalent smooth impervious surface), and the use of asphalt concrete shall be prohibited.
- c. The fuel dispensing area must have a 2% to 4% slope to prevent ponding, and must be separated from the rest of the site by a grade break that prevents run-on of stormwater to the extent practicable.
- d. At a minimum, the concrete fuel dispensing area must extend 6.5 feet (2.0 meters) from the corner of each fuel dispenser, or the length at which the hose and nozzle assembly may be operated plus 1 foot (0.3 meter), whichever is less.

##### 2. Properly Design Repair/Maintenance Bays

Oil and grease, solvents, car battery acid, coolant and gasoline from the repair/maintenance bays can negatively impact stormwater if allowed to come into contact with stormwater runoff. Therefore, design plans for repair bays must include the following:

- a. Repair/maintenance bays must be indoors or designed in such a way that doesn't allow stormwater run-on or contact with stormwater runoff.
- b. Design a repair/maintenance bay drainage system to capture all wash-water, leaks and spills. Connect drains to a sump for collection and disposal. Direct connection of the repair/maintenance bays to the stormwater system is prohibited. If direct connection with a city sanitary sewer, it is required that a Industrial Waste Discharge Permit be obtained by that jurisdiction.

##### 3. Properly Design Vehicle/Equipment Wash Areas

The activity of vehicle/equipment washing/steam cleaning has the potential to contribute metals, oil and grease, solvents, phosphates, and suspended solids to the stormwater conveyance system and watercourses. Include in the project plans an area for washing/steam cleaning of vehicles and equipment. This area must be:

- a. Self-contained and/or covered, equipped with a clarifier, or other pretreatment facility, and properly connected to a sanitary sewer or other appropriately permitted disposal facility.

##### 4. Properly Design Loading/Unloading Dock Areas

Loading/unloading dock areas have the potential for material spills to be quickly transported to the stormwater conveyance system or watercourses. To minimize this potential, the following design criteria are required:

- a. Cover loading dock areas or design drainage to minimize run-on and runoff of stormwater.
- b. Direct connections to storm drains from depressed loading docks (truck wells) are prohibited.

#### 11-5.3.5 Parking Lots

##### 1. Properly Design Parking Area

Parking lots contain pollutants such as heavy metals, oil and grease, and polycyclic aromatic hydrocarbons that are deposited on parking lot surfaces by motor vehicles. These pollutants are

directly transported to surface waters. To minimize the offsite transport of pollutants, the following design criteria are required:

- a. Reduce impervious land coverage of parking areas.
- b. Infiltrate or treat runoff.

2. Properly Design to Limit Oil Contamination and Perform Maintenance

Parking lots may accumulate oil, grease, and water insoluble hydrocarbons from vehicle drippings and engine system leaks:

- a. Treat to remove oil and petroleum hydrocarbons at parking lots that are heavily used (e.g. fast food outlets, lots with 25 or more parking spaces, sports event parking lots, shopping malls, grocery stores, discount warehouse stores).
- b. Ensure adequate operation and maintenance of treatment systems particularly sludge and oil removal, and system fouling and plugging prevention control.

<b>Standard Drawings</b>		
<b>Section 11 – Stormwater Quality, Erosion and Sediment Control</b>		
<b>Drawing</b>	<b>Sheets</b>	<b>Description</b>
11-1	1	Stabilized Construction Site Access
11-2	1 of 2	Sediment Trap Vegetated Outlet
11-2	2 of 2	Sediment Trap Stabilized Outlet
11-3	1 of 3	Typical Temporary Sediment Basin Single Orifice Design
11-3	2 of 3	Typical Temporary Sediment Basin Multiple Orifice Design
11-3	3 of 3	Multiple Orifice Outlet Riser
11-4	1 of 2	Erosion Control Blankets/Mats Channel Installation
11-4	2 of 2	Erosion Control Blankets/Mats Slope Installation
11-5	1 of 3	Silt Fence
11-5	2 of 3	Silt Fence Detail
11-5	3 of 3	Filter Barriers
11-6	1	Straw Bale Barrier
11-7	1 of 3	Storm Drain Inlet Filter
11-7	2 of 3	Storm Drain Inlet Filter Bag
11-7	3 of 3	Inlet Sediment Control
11-8	1	Fiber Rolls
11-9	1	Concrete Washout
11-10	1 of 2	Stormwater Quality Drop Inlet Concrete Stamp
11-10	2 of 2	Drop Inlet Stamp Messages & Symbols

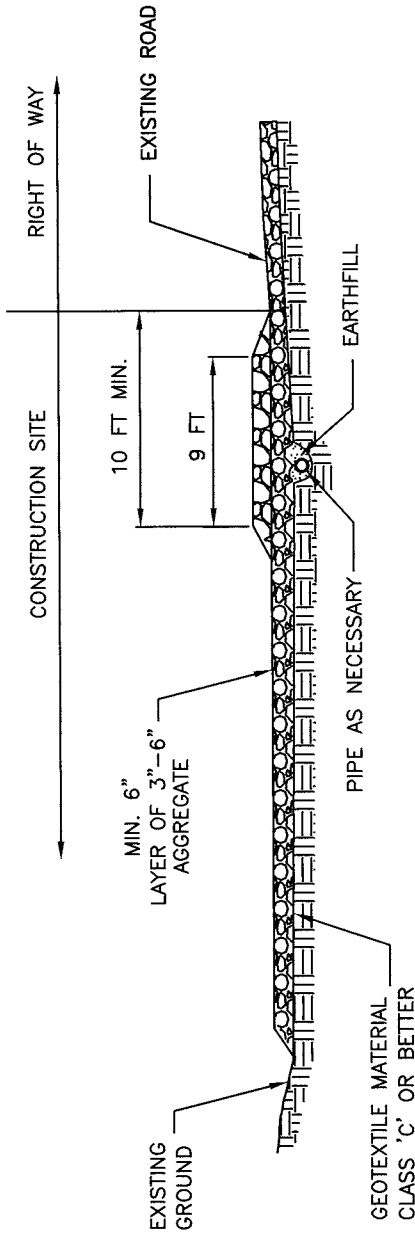

CONSTRUCTION ENTRANCE/EXIT

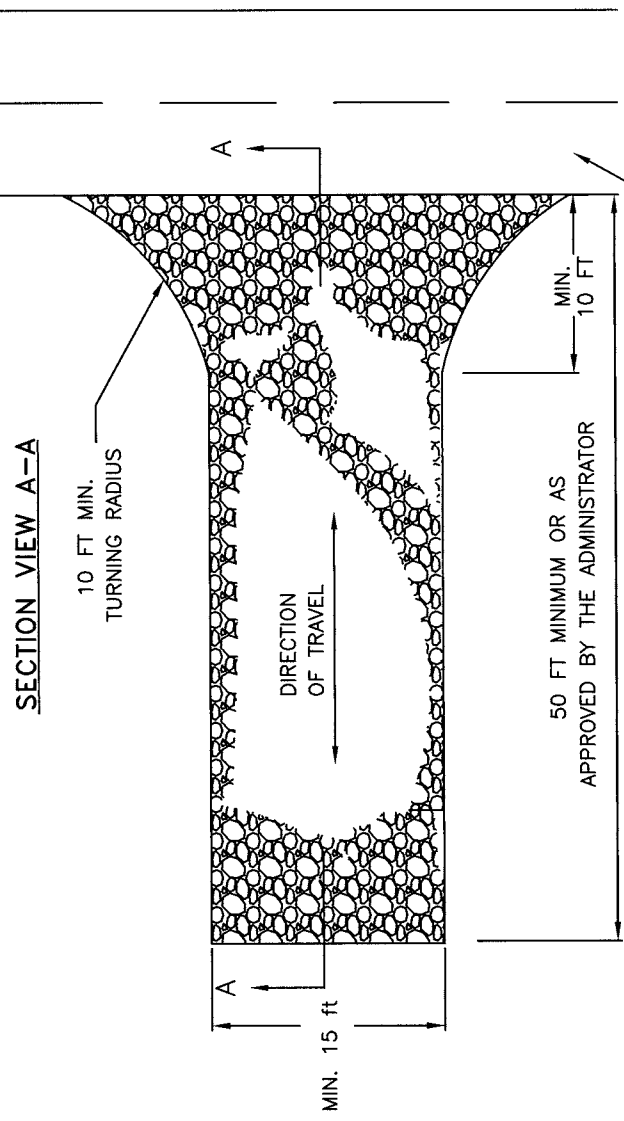

CONSTRUCTION ENTRANCE/EXIT

PLAN VIEW

NOTES:

1. STABILIZED CONSTRUCTION SITE ACCESS SHALL BE CONSTRUCTED OF 3 TO 6 INCH WASHED, WELL GRADED GRAVEL OR CRUSHED ROCK. MATERIAL SHALL BE PLACED TO A MINIMUM THICKNESS OF 6 INCHES.
2. LENGTH OF ENTRANCE SHALL BE A MINIMUM OF 50 FEET. WIDTH SHALL BE A MINIMUM OF 15 FEET OR GREATER IF NECESSARY TO COVER ALL VEHICULAR INGRESS AND EGRESS. PROVIDE AMPLE TURNING RADII.
3. THE ENTRANCE SHALL BE KEPT IN GOOD CONDITION BY OCCASIONAL TOP DRESSING WITH MATERIAL AS SPECIFIED IN NOTE 1.
4. ACCESSES SHALL BE INSPECTED WEEKLY DURING PERIODS OF HEAVY USAGE, MONTHLY DURING NORMAL USAGE, AND AFTER EACH RAINFALL, WITH MAINTENANCE PROVIDED AS NECESSARY. PERIODIC TOP DRESSING SHALL BE DONE AS NEEDED.

COUNTY OF YOLO PLANNING AND PUBLIC WORKS DEPARTMENT	DATE: 08/05/08
STABILIZED CONSTRUCTION SITE ACCESS	SHEET # 1 OF 1
<i>Paros Kollas</i> COUNTY ENGINEER No. C42401	DRAWING #: 11-1 NOT TO SCALE
APPROVAL DATE <i>28 AUG. 08</i>	

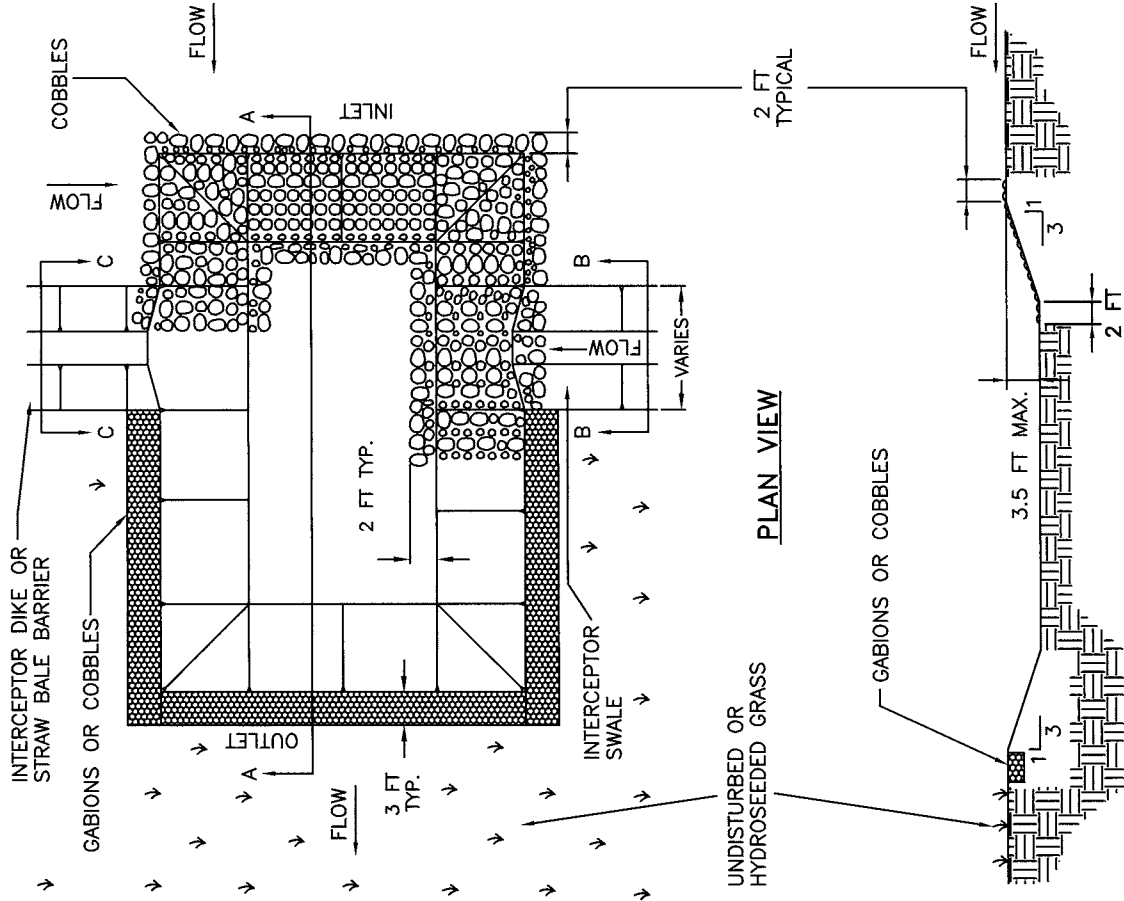

PLAN VIEW

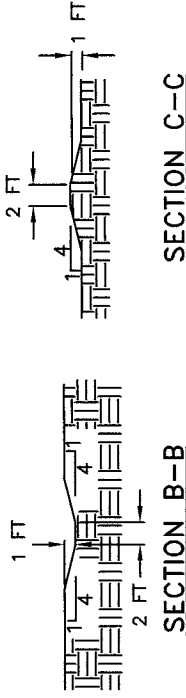

SECTION B-B

SECTION C-C

**NOTES:**

1. DIMENSIONS OF SEDIMENT TRAPS, DIKES, AND SWALES SHALL BE APPROVED BY THE COUNTY ENGINEER.
2. INTERCEPTION DIKES AND SWALES SHALL BE CONSTRUCTED TO DRAIN SURFACE RUNOFF INTO SEDIMENT TRAPS.
3. TRAPS SHALL BE EXCAVATED WITH APPROPRIATE EQUIPMENT, TAKING CARE NOT TO DISTURB VEGETATION OR SOIL AT OUTLET CREST. SIDE SLOPES SHALL BE 3:1 OR FLATTER. MAXIMUM TRAP DEPTH SHALL BE 3.5 FEET.
4. 4" TO 6" COBBLES CONFORMING TO STATE STANDARD SPECIFICATIONS SHALL BE PLACED ON THE TOPS AND BOTTOMS OF THE INLET SIDES. COBBLES SHALL EXTEND A MINIMUM OF 2 FEET BEYOND THE TOP AND TOE OF SLOPES.
5. PERIMETER OF THE SEDIMENT TRAP SHALL BE HYDROSEEDED 10 FEET BEYOND EDGE OF EXCAVATION IF EXISTING VEGETATION IS THIN, DISTURBED, OR NONEXISTENT.
6. THE CONTRACTOR SHALL INSPECT SEDIMENT TRAPS WEEKLY AND AFTER EACH RAINFALL AND REPAIR AS NECESSARY. SEDIMENT SHALL BE REMOVED FROM THE BOTTOM OF THE TRAP BEFORE IT REACHES 1 FOOT DEEP, AND DISPOSED PROPERLY.
7. THIS TRAP SHALL BE USED ONLY WHEN THERE IS NO EXISTING DOWNSTREAM DRAINAGE COURSE, OR WHEN IT IS DESIRABLE TO KEEP ALL RUNOFF WATER WITHIN CONSTRUCTION BOUNDARIES.

COUNTY OF YOLO PLANNING AND PUBLIC WORKS DEPARTMENT	DATE: 08/05/08
SEDIMENT TRAP VEGETATED OUTLET	SHEET # 1 OF 2
<i>Karnes</i> COUNTY ENGINEER No. C42401	DRAWING #: 11-2 NOT TO SCALE
<i>Kobles</i> APPROVAL DATE 28 Aug. 08	

SECTION A-A



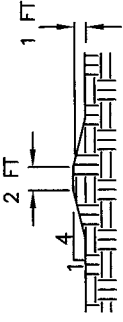
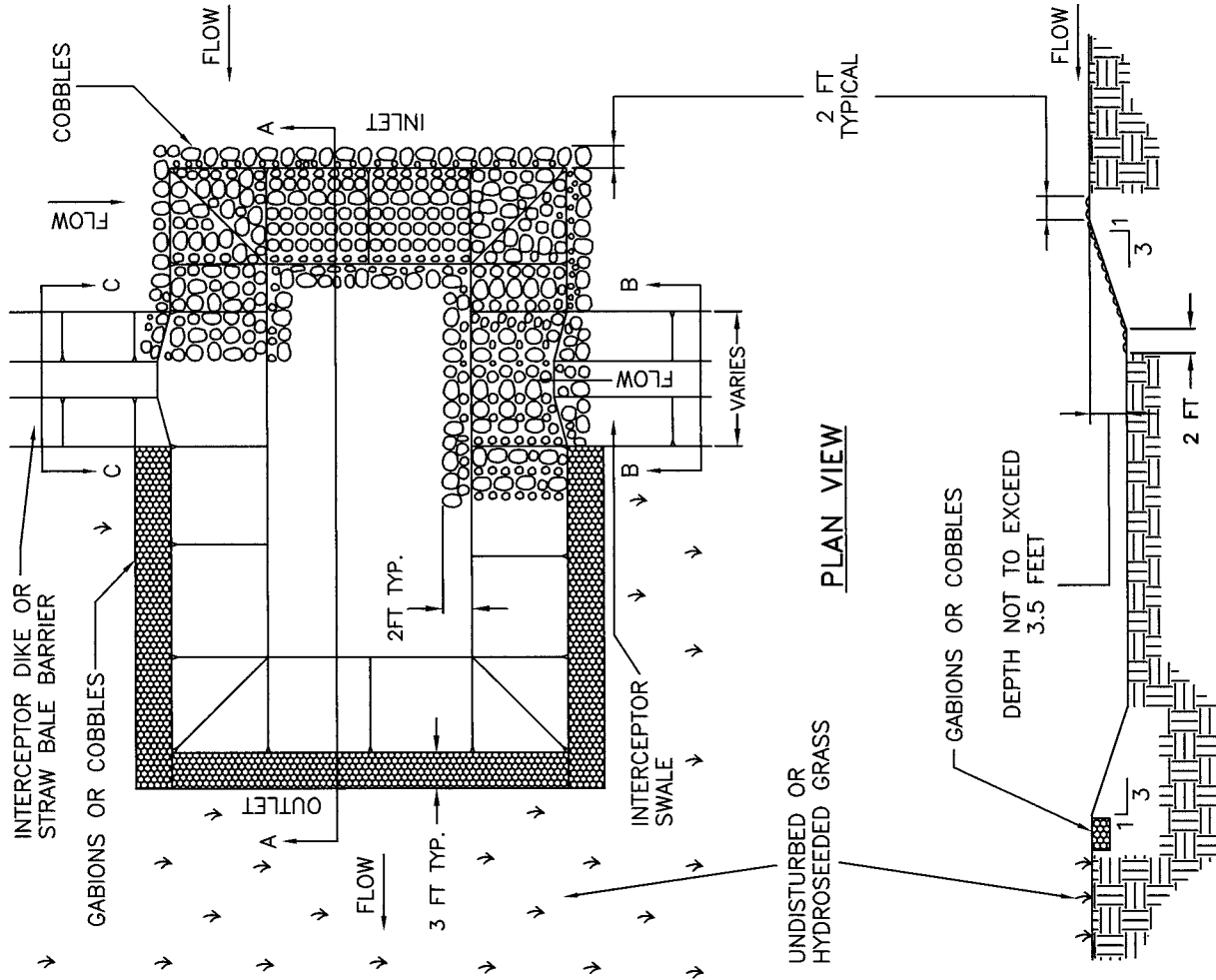

SECTION B-B

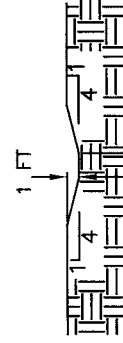

SECTION C-C

**NOTES:**

1. DIMENSIONS OF SEDIMENT TRAPS, DIKES, AND SWALES SHALL BE APPROVED BY THE COUNTY ENGINEER.
2. INTERCEPTION DIKES AND SWALES SHALL BE CONSTRUCTED TO DRAIN SURFACE RUNOFF INTO SEDIMENT TRAPS.
3. TRAPS SHALL BE EXCAVATED WITH APPROPRIATE EQUIPMENT, TAKING CARE NOT TO DISTURB VEGETATION OR SOIL AT OUTLET CREST. SIDE SLOPES SHALL BE 3:1 OR FLATTER. MAXIMUM TRAP DEPTH SHALL BE 3.5 FEET.
4. COBBLES CONFORMING TO STATE STANDARD SPECIFICATIONS SHALL BE PLACED ON THE TOPS, SLOPES, AND BOTTOMS OF THE INLET SIDES. COBBLES SHALL EXTEND A MINIMUM OF 2 FEET BEYOND THE TOP AND TOE OF SLOPES.
5. PERIMETER OF SEDIMENT TRAPS SHALL BE STABILIZED WITH GABIONS OR COBBLES AND HYDROSEEDED 10 FEET BEYOND EDGE OF EXCAVATION IF EXISTING VEGETATION IS THIN, DISTURBED OR NONEXISTENT.
6. THE CONTRACTOR SHALL INSPECT SEDIMENT TRAPS WEEKLY AND AFTER EACH RAINFALL AND REPAIR AS NECESSARY. SEDIMENT SHALL BE REMOVED FROM THE BOTTOM OF THE TRAP WHEN 300 MM (1 FOOT) DEEP OR LESS.
7. SEE NOTE 7 (DETAIL 11-2).

COUNTY OF YOLO PLANNING AND PUBLIC WORKS DEPARTMENT	DATE:	08/05/08
	SHEET #	2 OF 2
SEDIMENT TRAP STABILIZED OUTLET	APPROVAL DATE	28 AUG. 08
	DRAWING #:	11-2
COUNTY ENGINEER No. C42401 <i>Ramos Koplas</i>		NOT TO SCALE

SECTION A-A

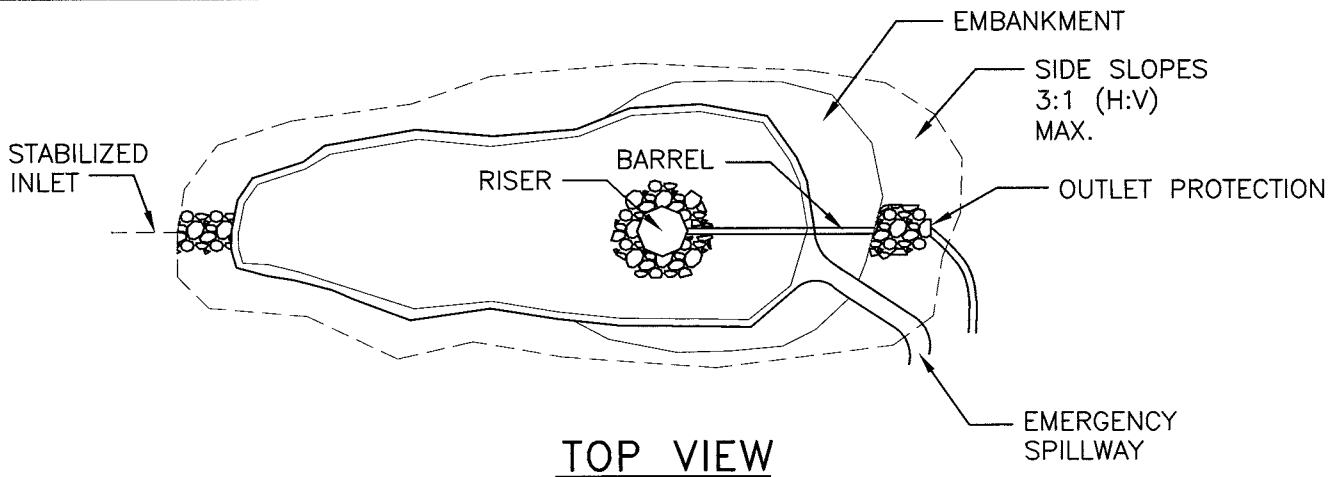

**TOP VIEW**

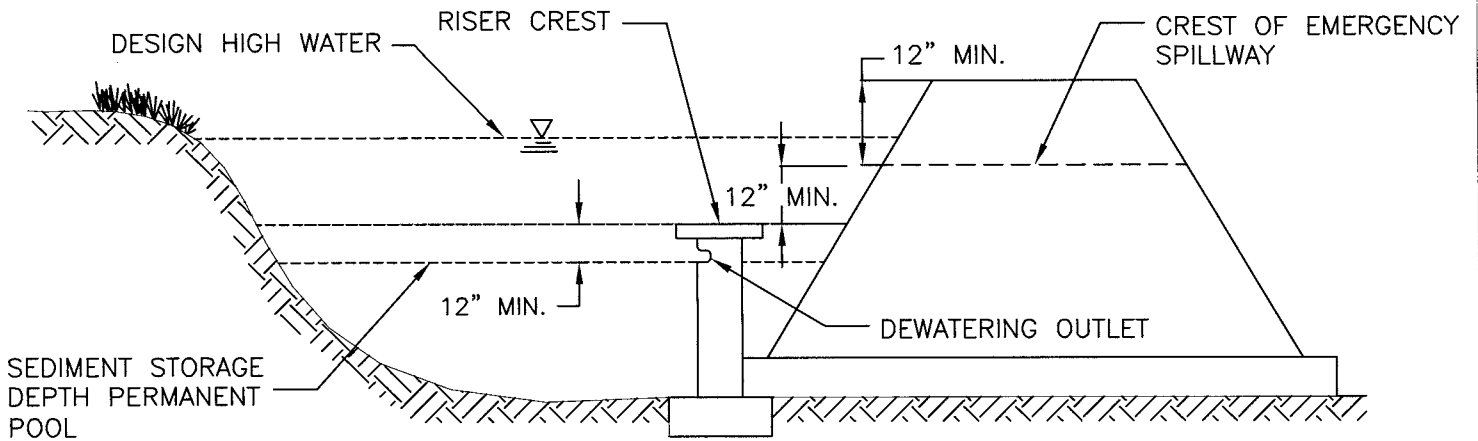

**SIDE VIEW**

**NOTE:**

1. THIS OUTLET PROVIDES NO DRAINAGE FOR PERMANENT POOL.
2. CONSTRUCT BEFORE CLEARING AND GRADING WORK BEGINS, WHEN FEASIBLE.
3. DO NOT LOCATE IN AN UNDISTURBED STREAM OR OTHER WATERCOURSE.
4. BASIN SITES SHOULD BE LOCATED WHERE FAILURE OF THE STRUCTURE WILL NOT CAUSE LOSS OF LIFE, DAMAGE TO HOMES OR BUILDINGS, OR INTERRUPTION OF USE OR SERVICE OF PUBLIC ROADS OR UTILITIES.
5. LARGE BASINS ARE SUBJECT TO STATE AND LOCAL DAM SAFETY REQUIREMENTS.
6. LIMIT THE CONTRIBUTING AREA TO ONLY THE RUNOFF FROM DISTURBED SOIL AREAS.
7. THE BASIN SHOULD BE LOCATED:
  - A. BY EXCAVATING A SUITABLE AREA OR WHERE LOW EMBANKMENT CAN BE CONSTRUCTED ACROSS A SWALE,
  - B. WHERE POST-CONSTRUCTION (PERMANENT) DETENTION BASINS WILL BE CONSTRUCTED, AND
  - C. WHERE THE BASIN CAN BE MAINTAINED ON A YEAR-ROUND BASIS TO PROVIDE ACCESS FOR MAINTENANCE INCLUDING SEDIMENT REMOVAL AND SEDIMENT STOCKPILING IN A PROTECTED AREA, AND TO MAINTAIN THE REQUIRED STORMWATER CAPACITY.

<b>COUNTY OF YOLO</b> PLANNING AND PUBLIC WORKS DEPARTMENT		DATE: 08/05/08
<b>TYPICAL TEMPORARY SEDIMENT          BASIN SINGLE ORIFICE DESIGN</b>		SHEET # 1 OF 3
<i>Paros Kallas</i> COUNTY ENGINEER No. C42401		28 AUG. 08 APPROVAL DATE
		DRAWING #: <b>11-3</b> NOT TO SCALE

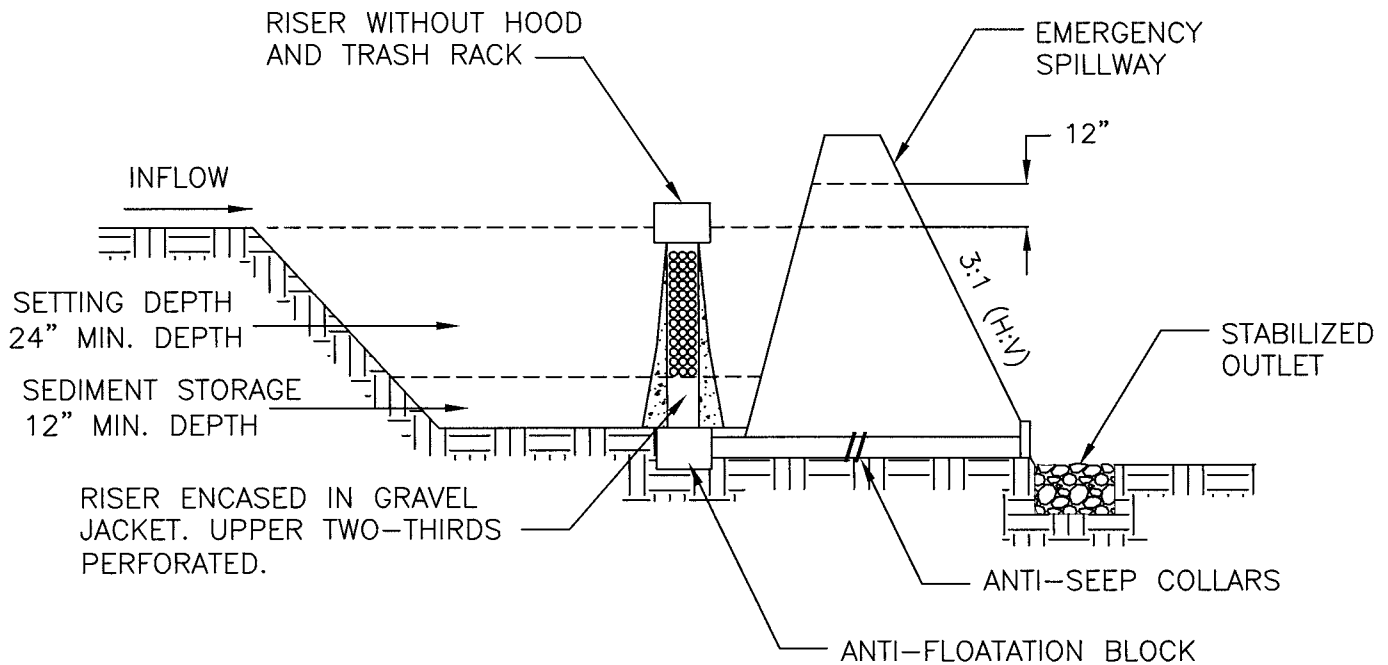
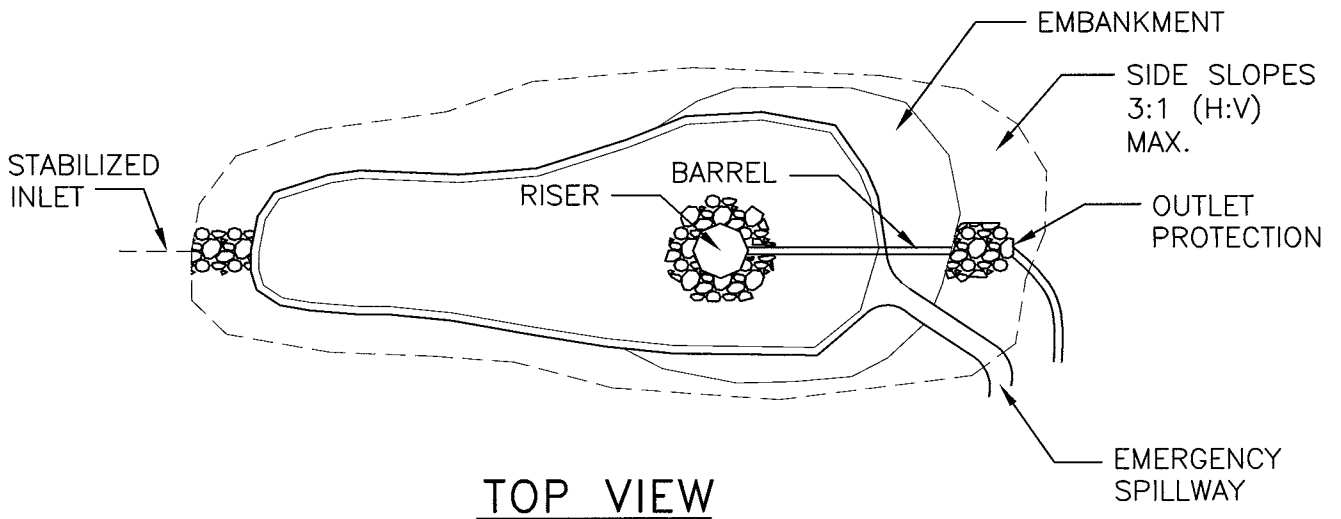

<b>COUNTY OF YOLO</b> PLANNING AND PUBLIC WORKS DEPARTMENT		DATE: 08/05/08
TYPICAL TEMPORARY SEDIMENT BASIN MULTIPLE ORIFICE DESIGN		SHEET # 2 OF 3
<i>Paros Kallas</i> COUNTY ENGINEER No. C42401	28 AUG. 08 APPROVAL DATE	DRAWING #: 11-3 NOT TO SCALE

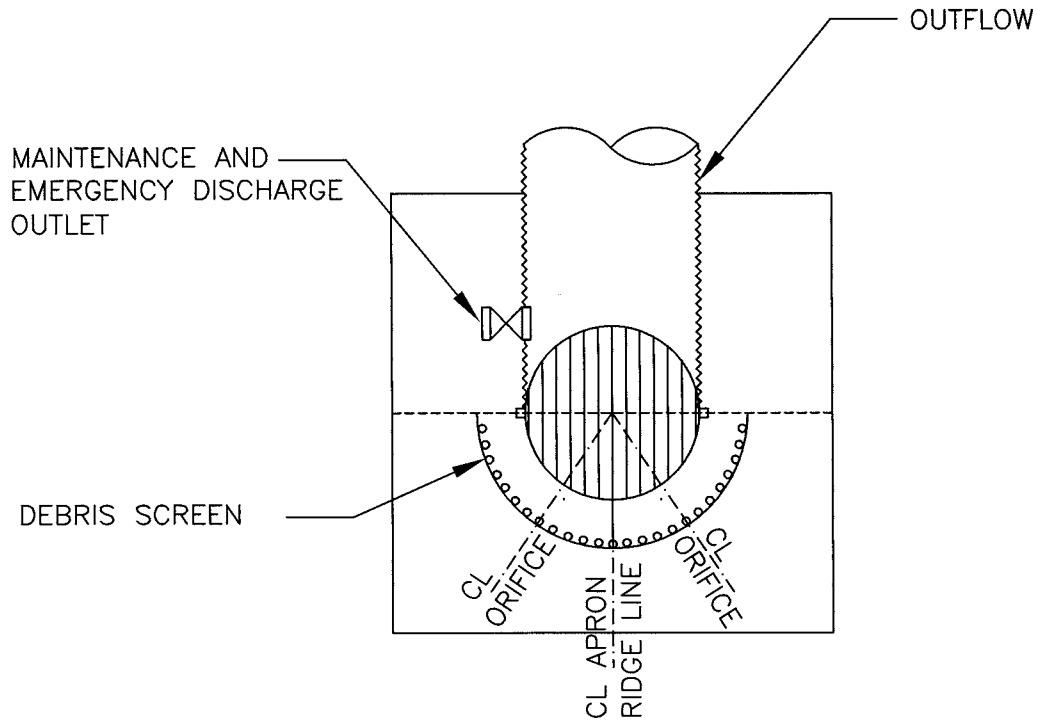

PLAN

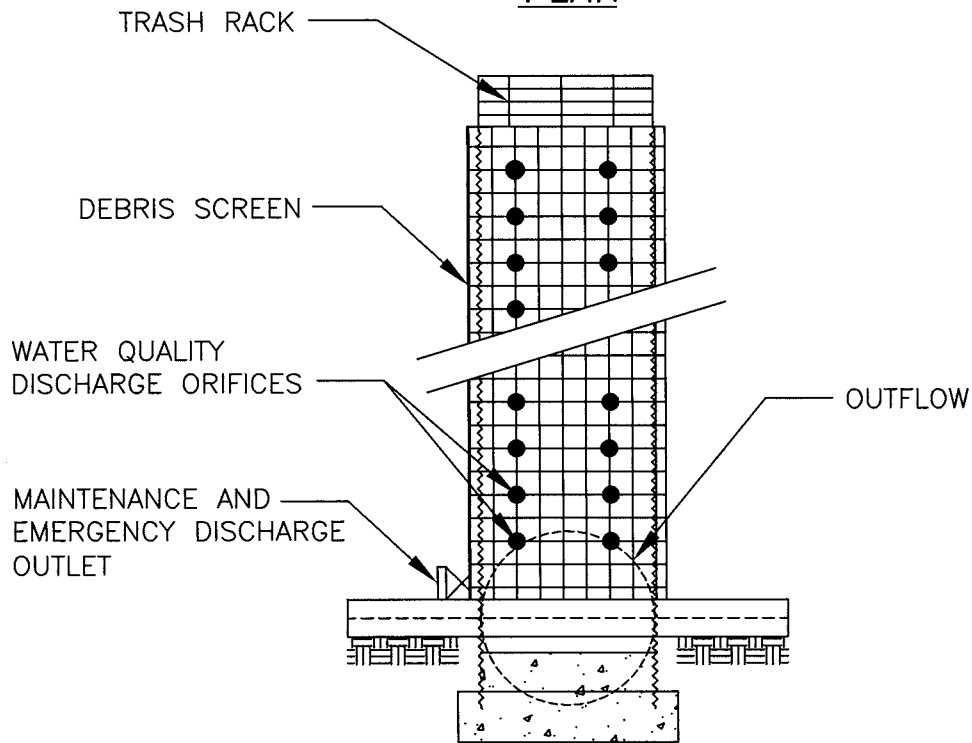

PROFILE

<b>COUNTY OF YOLO</b> PLANNING AND PUBLIC WORKS DEPARTMENT		DATE: 08/05/08
MULTIPLE ORIFICE OUTLET RISER		SHEET # 3 OF 3
<i>Paras Kollas</i> COUNTY ENGINEER No. C42401		<i>28 AUG. 08</i> APPROVAL DATE
		DRAWING #: <b>11-3</b> NOT TO SCALE

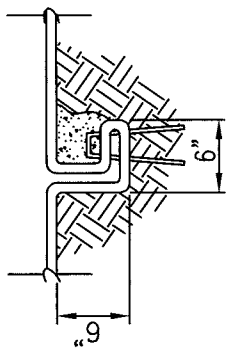

CHECK SLOT

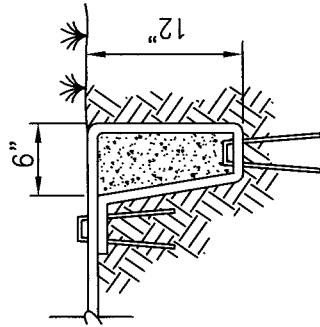

INITIAL CHANNEL ANCHOR TRENCH

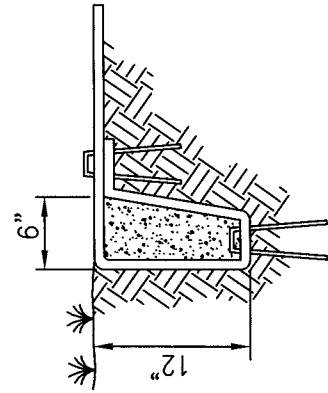

TERMINAL SLOPE AND CHANNEL ANCHOR TRENCH

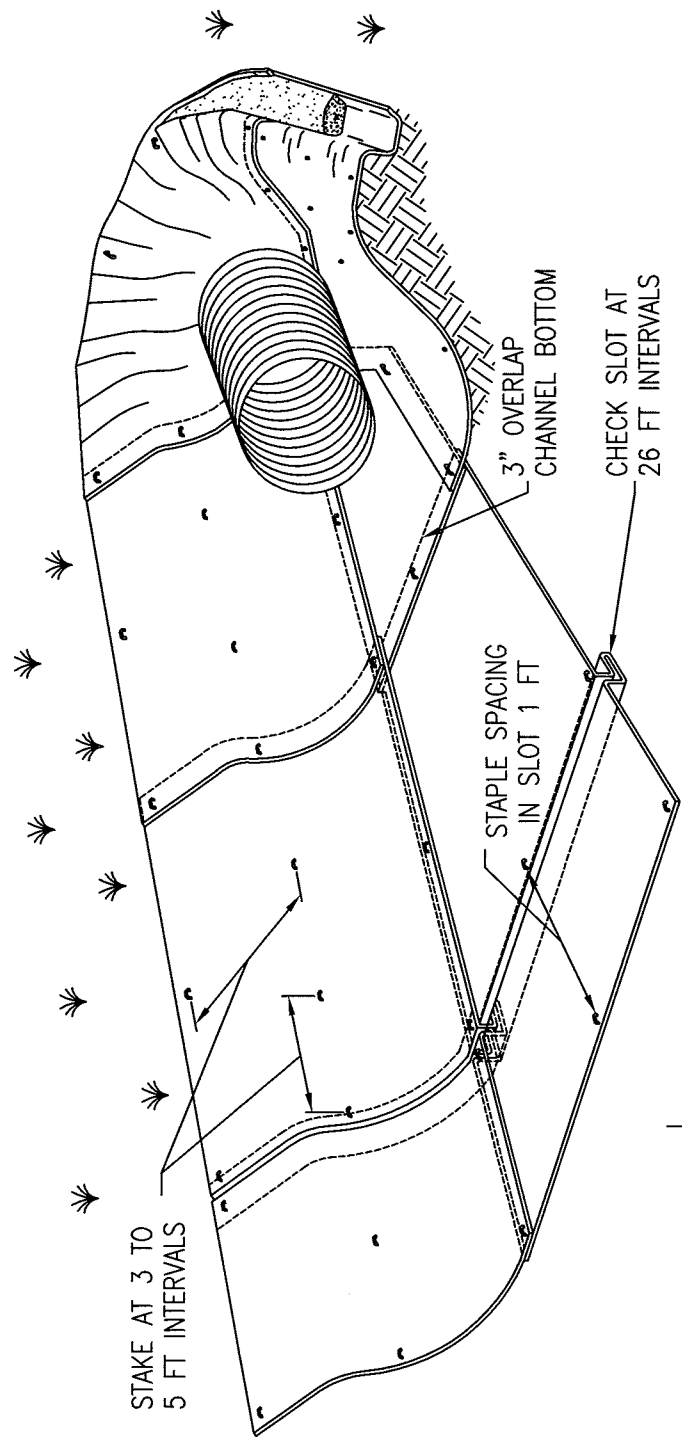

TYPICAL CHANNEL SOIL STABILIZATION

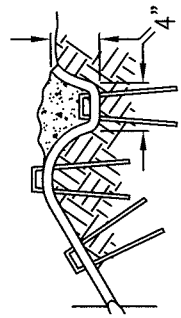

LONGITUDINAL ANCHOR TRENCH

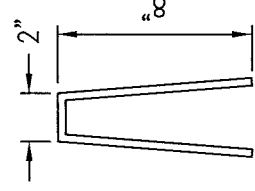

WIRE STAPLES

NOTE:

1. CONSTRUCTION OF CHECK SLOTS, STAKING, STAPLING LAYOUT, AND MAT INSTALLATION ALL TO BE DONE PER MANUFACTURER'S SPECIFICATIONS.

COUNTY OF YOLO PLANNING AND PUBLIC WORKS DEPARTMENT	DATE: 08/05/08
EROSION CONTROL BLANKETS/MATS CHANNEL INSTALLATION	SHEET # 1 OF 2
<i>Carroll Kothas</i> COUNTY ENGINEER No. C42401	DRAWING #: 11-4 APPROVAL DATE: 28 AUG 08 NOT TO SCALE

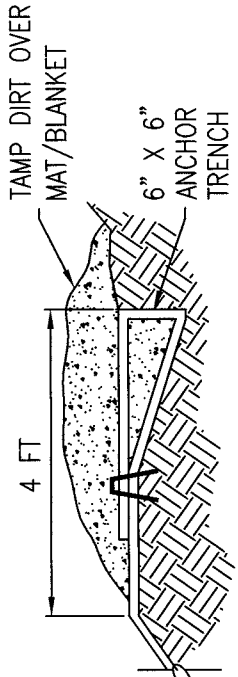

ANCHOR DETAIL

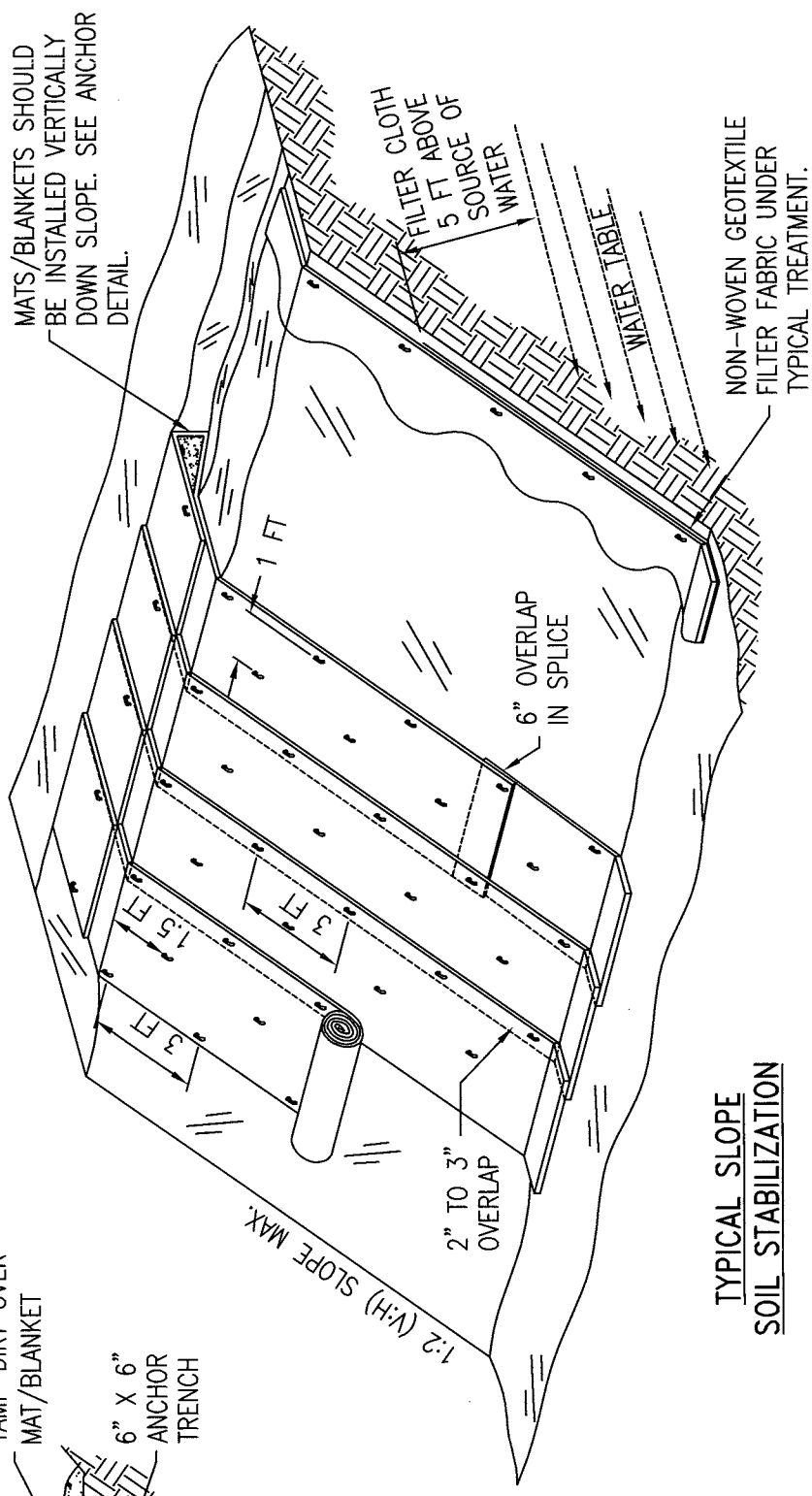

TYPICAL SLOPE SOIL STABILIZATION

WET SLOPE LINING

NOTES:

1. SLOPE SURFACE SHALL BE FREE OF ROCKS, CLODS, STICKS AND GRASS. MATS/BLANKETS SHALL HAVE GOOD SOIL CONTACT.
2. LAY BLANKETS LOOSELY AND STAKE OR STAPLE TO MAINTAIN DIRECT CONTACT WITH THE SOIL. DO NOT STRETCH.
3. INSTALL PER MANUFACTURER'S RECOMMENDATIONS.

COUNTY OF YOLO PLANNING AND PUBLIC WORKS DEPARTMENT	DATE: 08/05/08
EROSION CONTROL BLANKETS/MATS SLOPE INSTALLATION	SHEET # 2 OF 2
<i>James Walker</i> COUNTY ENGINEER No. C42401	DRAWING #: 11-4 NOT TO SCALE
<i>28 AUG. 08</i> APPROVAL DATE	

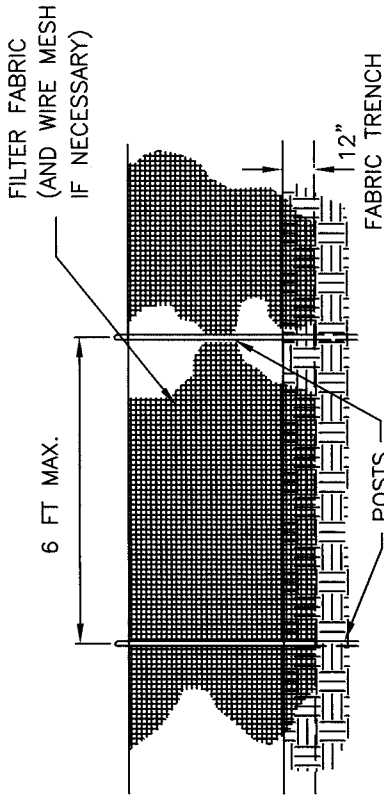

**FRONT VIEW**

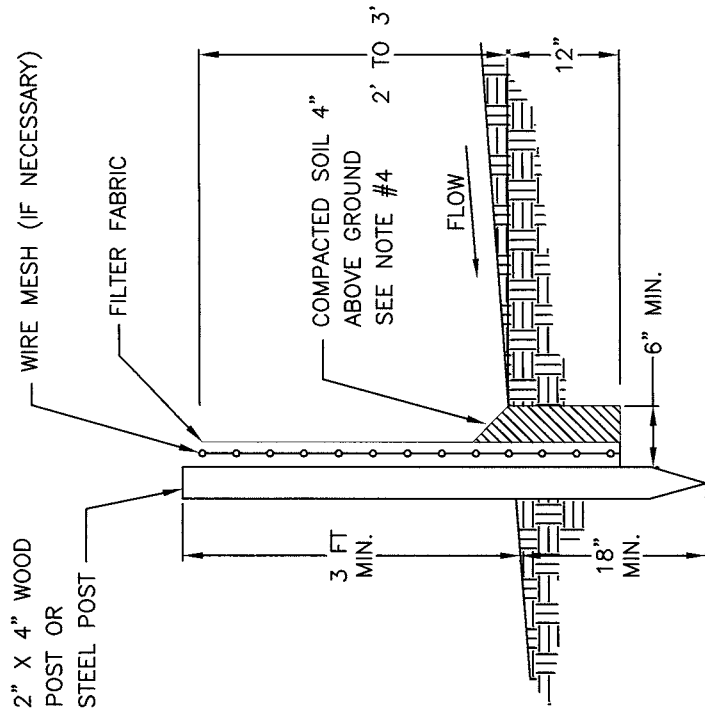

**SECTION A-A**

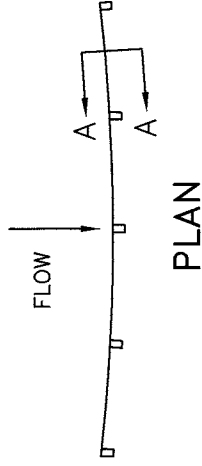

**PLAN**

**NOTES:**

1. SILT FENCE SHALL BE CONSTRUCTED LONG ENOUGH TO EXTEND ACROSS THE EXPECTED FLOW PATH AND AS APPROVED BY THE COUNTY ENGINEER. THE MAXIMUM DISTANCE BETWEEN SILT FENCES SHALL BE 30 FEET X THE SLOPE EXPRESSED AS A RATIO.
2. FILTER FABRIC SHALL BE PROPYLENE, NYLON, POLYESTER OR ETHYLENE YARN WITH A MINIMUM TENSILE STRENGTH OF 50 LBS. PER LINEAR FOOT AT 20 PERCENT MAXIMUM ELONGATION AND CONTAINING ULTRAVIOLET INHIBITORS. FILTER FABRIC SHALL RETAIN A MINIMUM OF 85% OF THE SOIL, BY WEIGHT, BASED ON SIEVE ANALYSIS, BUT IS NOT FINER THAN AN EQUIVALENT OPENING SIZE OF 70. WHEN STANDARD STRENGTH FABRIC IS USED, A WIRE MESH SUPPORT SHALL BE SECURELY FASTENED TO THE UPSLOPE SIDE OF POSTS.
3. SUPPORT POSTS SHALL BE A MINIMUM 4.5 FEET LONG 2"x4" WOOD POSTS OR 'T' SECTION FENCE POSTS DRIVEN A MINIMUM OF 18" INTO THE GROUND. POSTS SHALL BE SPACED A MAXIMUM OF 6 FEET APART. FABRIC SHALL BE SECURELY FASTENED TO TO POSTS WITH 1/2" STAPLES OR 16 GAUGE WIRE TIES SPACED A MAXIMUM OF 6" APART.
4. A 12" DEEP FABRIC TRENCH SHALL BE EXCAVATED ALONG THE UPHILL SIDE OF SILT FENCE POSTS. THE BOTTOM EDGE OF THE FABRIC SHALL EXTEND TO AND ACROSS THE BOTTOM OF THE TRENCH. THE TRENCH SHALL BE BACKFILLED TO 4" ABOVE GROUND AND COMPACTED TO BURY AND SECURE THE BOTTOM OF THE FILTER FABRIC.
5. CONTRACTOR SHALL MAKE INSPECTIONS WEEKLY DURING THE WET SEASON, MONTHLY DURING THE DRY SEASON AND IMMEDIATELY AFTER EACH RAINFALL TO DETERMINE IF REPAIRS AND SEDIMENT REMOVAL IS REQUIRED. SEDIMENT SHALL BE REMOVED BEFORE IT HAS REACHED ONE THIRD THE HEIGHT OF THE FILTER FABRIC.

COUNTY OF YOLO PLANNING AND PUBLIC WORKS DEPARTMENT	DATE: 08/05/08
SILT FENCE	SHEET # 1 OF 3
<i>Parsons</i> COUNTY ENGINEER No. C42401	DRAWING #: 11-5 NOT TO SCALE
<i>28 Aug-08</i> APPROVAL DATE	

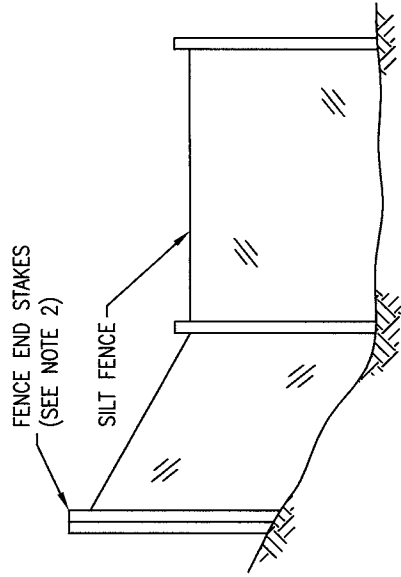

**NOTES:**

1. CONSTRUCT THE LENGTH OF EACH REACH SO THAT THE CHANGE IN BASE ELEVATION ALONG THE REACH DOES NOT EXCEED 1/3 OF THE HEIGHT OF THE LINEAR BARRIER. IN NO CASE SHALL THE REACH LENGTH EXCEED 500 FT.
2. THE LAST 8 FT OF FENCE SHALL BE TURNED UP SLOPE.
3. STAKE DIMENSIONS ARE NOMINAL.
4. DIMENSIONS MAY VARY TO FIT FIELD CONDITION.
5. STAKES SHALL BE SPACED AT 8 FT MAXIMUM AND SHALL BE POSITIONED ON THE DOWNSTREAM SIDE OF THE FENCE.
6. OVERLAP STAKES, AND FOLD FENCE FABRIC TO AROUND EACH STAKE ONE FULL TURN.
7. STAKES SHALL BE DRIVEN TIGHTLY TOGETHER TO PREVENT POTENTIAL FLOW THROUGH OF SEDIMENT AT THE JOINT.
8. FOR END STAKE CONDITION FOLD FENCE FABRIC AROUND TWO (2) STAKES ONE (1) FULL TURN AND SECURE WITH (4) STAPLES.
9. MINIMUM (4) STAPLES PER STAKE.
10. CROSS BARRIERS SHALL BE A MINIMUM OF 1/3 AND A MAXIMUM OF 1/2 THE HEIGHT OF THE LINEAR BARRIER.

**STAPLE DETAIL**

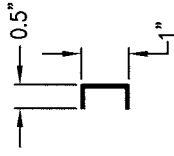

**FENCE END DETAIL**

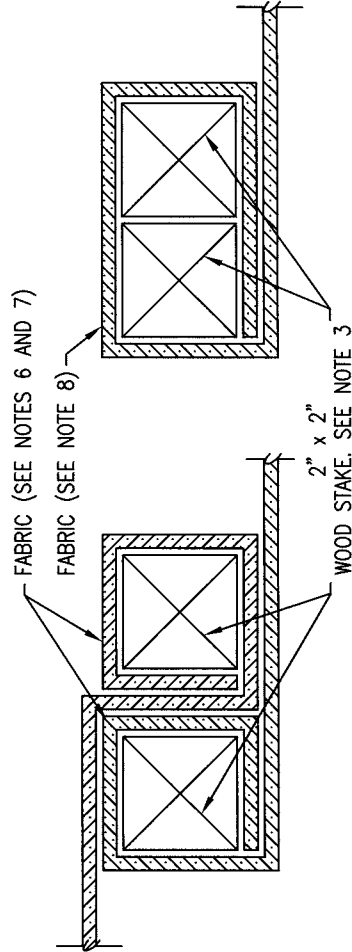

**JOINT DETAIL**

**END STAKE DETAIL**

<b>COUNTY OF YOLO</b>	DATE: 08/05/08
PLANNING AND PUBLIC WORKS DEPARTMENT	SHEET # 2 OF 3
SILT FENCE DETAIL	DRAWING #: 11-5
<i>James Walker</i> COUNTY ENGINEER No. C42401	APPROVAL DATE 28MAY.08 NOT TO SCALE



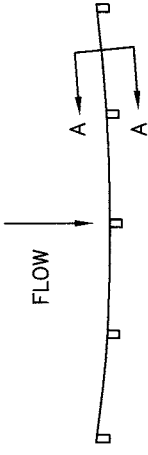

PLAN

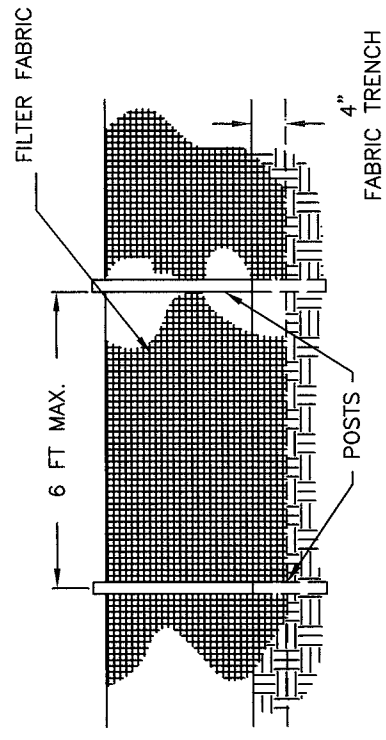

FRONT VIEW

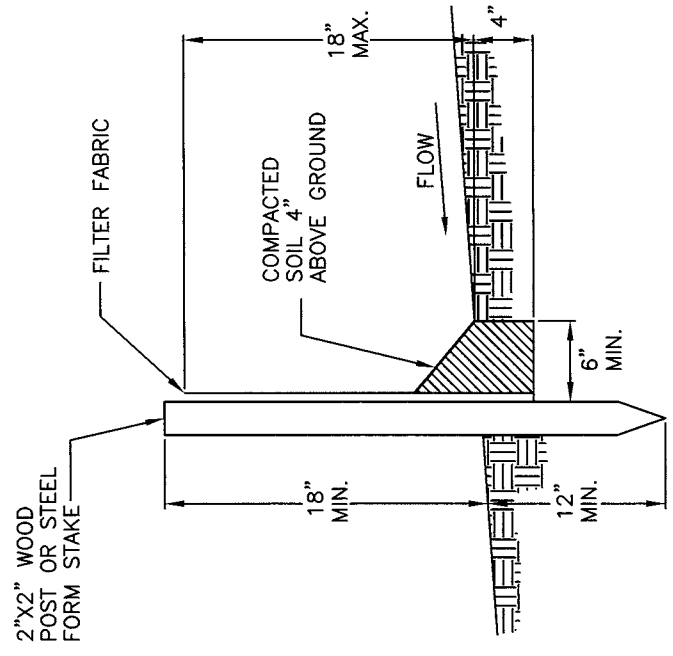

SECTION A-A

**NOTES:**

1. FILTER BARRIER SHALL BE CONSTRUCTED LONG ENOUGH TO EXTEND ACROSS THE EXPECTED FLOW PATH AND AS APPROVED BY THE ADMINISTRATOR. THE MAXIMUM DISTANCE BETWEEN FILTER BARRIERS SHALL BE 15 FT X THE SLOPE EXPRESSED AS A RATIO.
2. FILTER FABRIC SHALL BE PROPYLENE, NYLON, POLYESTER OR ETHYLENE YARN WITH A MINIMUM TENSILE STRENGTH OF 50 LBS. PER LINEAR FOOT AT 20 PERCENT MAXIMUM ELONGATION AND CONTAINING ULTRAVIOLET INHIBITORS. FILTER FABRIC SHALL RETAIN A MINIMUM OF 85% OF THE SOIL, BY WEIGHT, BASED ON SIEVE ANALYSIS, BUT IS NOT FINER THAN AN EQUIVALENT OPENING SIZE OF 70.
3. SUPPORT POSTS SHALL BE A MINIMUM 30" LONG 2"x2" WOOD POSTS OR STEEL FORM STAKES DRIVEN A MINIMUM OF 12" INTO THE GROUND. POSTS SHALL BE SPACED A MAXIMUM OF 6 FT APART. FABRIC SHALL BE SECURELY FASTENED TO POSTS WITH 0.5" STAPLES OR 16 GAUGE WIRE TIES SPACED A MAXIMUM OF 6" APART.
4. A 4" DEEP FABRIC TRENCH SHALL BE EXCAVATED ALONG THE UPHILL SIDE OF FILTER BARRIER POSTS. THE BOTTOM EDGE OF THE FABRIC SHALL EXTEND TO AND ACROSS THE BOTTOM OF THE TRENCH. THE TRENCH SHALL BE BACKFILLED TO 4" ABOVE GROUND AND COMPACTED TO BURY AND SECURE THE BOTTOM OF THE FILTER FABRIC.
5. CONTRACTOR SHALL MAKE INSPECTIONS WEEKLY DURING THE WET SEASON, BEFORE AND IMMEDIATELY AFTER EACH RAINFALL EVENT, AND MONTHLY DURING THE DRY SEASON TO DETERMINE IF REPAIRS AND SEDIMENT REMOVAL ARE REQUIRED. SEDIMENT SHALL BE REMOVED BEFORE IT HAS REACHED ONE THIRD (1/3) THE HEIGHT OF THE FILTER FABRIC.

COUNTY OF YOLO PLANNING AND PUBLIC WORKS DEPARTMENT	DATE: 08/05/08
	SHEET # 3 OF 3
FILTER BARRIERS	DRAWING #: 11-5
COUNTY ENGINEER No. C42401 <i>James Walker</i>	APPROVAL DATE 28 Aug. 08
NOT TO SCALE	

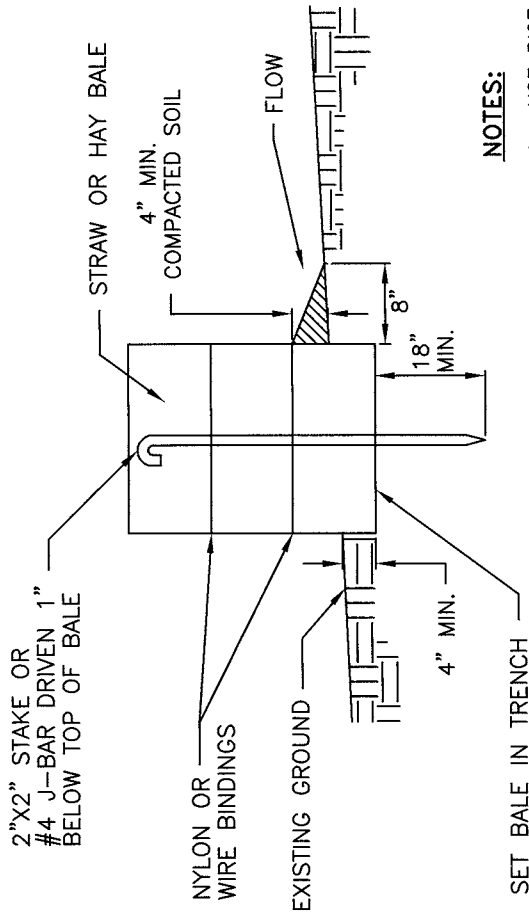

**SECTION A-A**

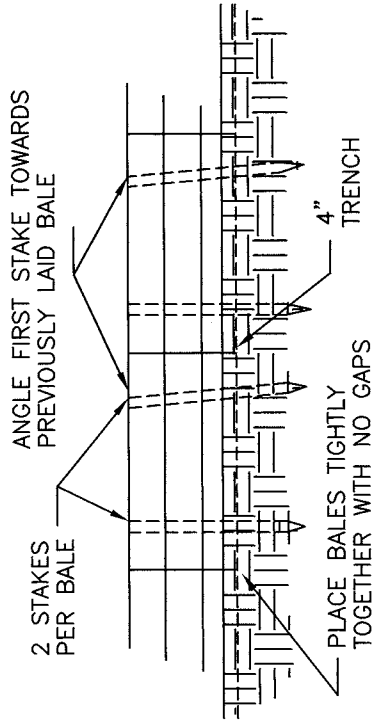

**FRONT VIEW**

**NOTES:**

1. USE RICE/STRAW BALE BARRIERS TO DECREASE THE VELOCITY OF LOW-TO-MODERATE LEVEL CHANNEL FLOWS. DO NOT PLACE ACROSS STREAMS, DITCHES, OR WHERE FLOWS ARE CONCENTRATED. THE DRAINAGE AREA MUST BE RESTRICTED AND THE BARRIER LOCATED SO THAT THE WATER DEPTH DOES NOT EXCEED 1 FOOT AT ANY POINT.
2. PLACE BALES IN 4" DEEP TRENCH ALONG THE CONTOUR OF THE SLOPE IN THE SHAPE OF THE AN ARC WITH THE ENDS UPHILL OF THE ARC'S CENTER. BALES SHALL BE PLACED SO THAT BINDINGS ARE HORIZONTAL. MAXIMUM SPACING BETWEEN ROWS SHALL BE 30 FEET x THE SLOPE STEEPNESS EXPRESSED AS A RATIO.
3. BALES SHALL BE ANCHORED BY TWO 2"x2" STAKES OR #4 J-BAR DRIVEN THROUGH THE BALE AND INTO THE GROUND A MINIMUM DEPTH OF 18". STAKES OR J-BARS SHALL BE DRIVEN 1" OR MORE BELOW THE TOP OF THE BALE. THE FIRST STAKE OR J-BAR IN EACH BALE SHALL BE DRIVEN AT AN ANGLE TOWARDS THE PREVIOUSLY LAID BALE TO FORCE THE BALES TIGHTLY TOGETHER.
4. AFTER BALES ARE STAKED IN PLACE, EXCAVATED SOIL SHALL BE BACKFILLED AGAINST THE UPHILL SIDE TO A MINIMUM HEIGHT OF 4".
5. CONTRACTOR SHALL INSPECT BALES WEEKLY, BEFORE AND AFTER EACH RAIN EVENT. REPAIRS SHALL BE MADE AS NECESSARY AND SEDIMENT SHALL BE REMOVED WHEN IT HAS ACCUMULATED TO A DEPTH OF 6". SEDIMENT SHALL BE DISPOSED OF PROPERLY. BALES SHALL BE REPLACED WHEN THEY HAVE BEEN DAMAGED, COLLAPSED OR DECOMPOSED.
6. USE STRAW BALE BARRIERS TO PROVIDE EROSION PROTECTION AT OVERFLOW POINTS. STRAW BALE BARRIERS ARE TO PROVIDE BACK-UP PROTECTION, NOT AS FIRST LINE OF DEFENSE.

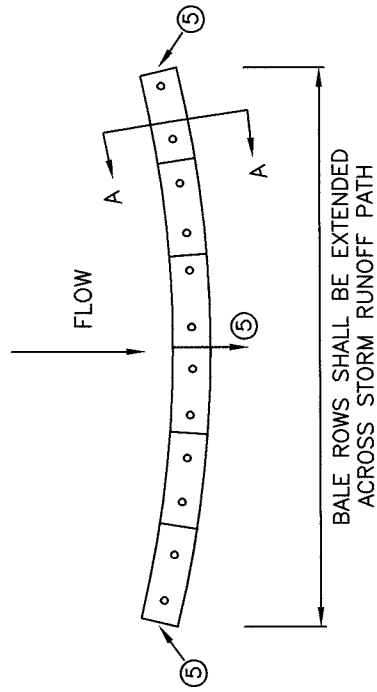

**BALE ROWS SHALL BE EXTENDED ACROSS STORM RUNOFF PATH**

**STRAW BALE ALIGNMENT**

<b>COUNTY OF YOLO</b>		DATE: 08/05/08
PLANNING AND PUBLIC WORKS DEPARTMENT		SHEET # 1 OF 1
STRAW BALE BARRIER		DRAWING #: 11-6
 COUNTY ENGINEER No. C42401		APPROVAL DATE: 28 Aug. 08
		NOT TO SCALE

**PLACEMENT AT TYPE B AND E DROP INLETS**

**PLACEMENT AT TYPE A, C, D AND F DROP INLETS AND PARKING LOTS**

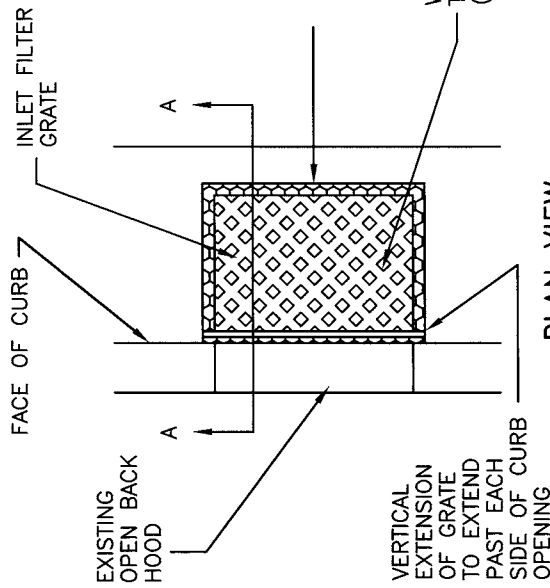

**PLAN VIEW**

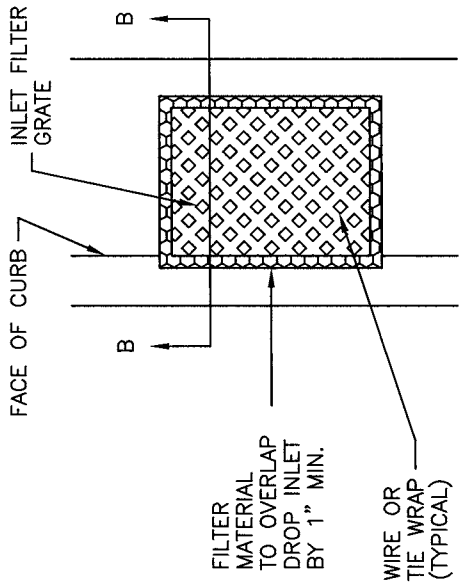

**PLAN VIEW**

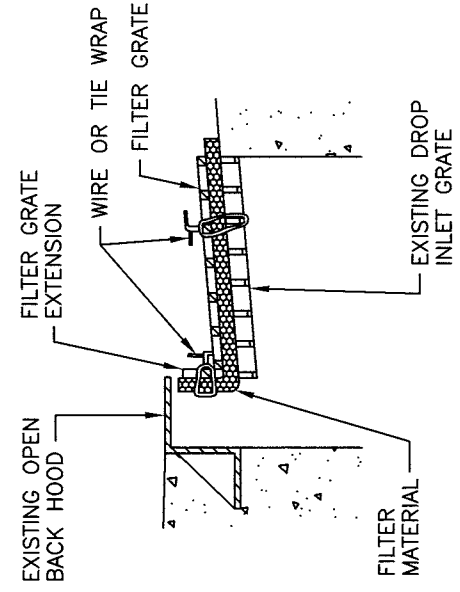

**SECTION A-A**

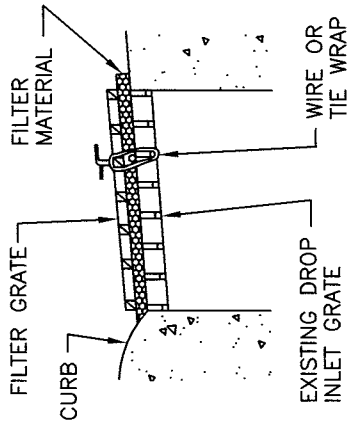

**SECTION B-B**

**NOTES:**

1. THE MAXIMUM DRAINAGE AREA PER FILTER SHALL BE NO MORE THAN 2 ACRES.
2. THE FILTER PAD SHALL BE 1" THICK CLEANABLE POLYESTER FIBER AND ACRYLIC LATEX RESIN OR APPROVED EQUIVALENT. THE FILTER PAD SHALL OVERLAP DROP INLET ON ALL SIDES BY A MINIMUM OF 1".
3. THE FILTER GRATE SHALL BE MADE OF EXPANDED METAL OR REBAR AND BE OF SUFFICIENT STRENGTH TO PREVENT BENDING WHEN DRIVEN OVER. GRATE MATERIAL SHALL NOT EXCEED 0.5" THICK. THE GRATE SHALL HAVE A MINIMUM 60% OPEN AREA. GRATES USED AT TYPE B AND E INLETS SHALL HAVE A VERTICAL EXTENSION TO COVER THE CURB OPENING. THE FILTER GRATE SHALL BE THE SAME SIZE AS THE DROP INLET GRATE.
4. THE FILTER PAD AND GRATE SHALL BE SECURELY ATTACHED TO THE DROP INLET BY WIRE OR TIE-WRAPPS.
5. INLET FILTERS SHALL BE INSPECTED WEEKLY, BEFORE AND AFTER EACH RAINFALL EVENT. REPAIRS SHALL BE MADE AS NEEDED. SEDIMENT AND DEBRIS SHALL BE REMOVED AND DISPOSED OF PROPERLY.

COUNTY OF YOLO PLANNING AND PUBLIC WORKS DEPARTMENT	DATE: 08/05/08
STORM DRAIN INLET FILTER	SHEET # 1 OF 3
COUNTY ENGINEER No. C42401 <i>James Hollas</i>	DRAWING #: 11-7 APPROVAL DATE: 28 AUG. 08 NOT TO SCALE

**PLACEMENT AT TYPE B AND E DROP INLETS**

**PLACEMENT AT TYPE A, C, D AND F DROP INLETS AND PARKING LOTS**

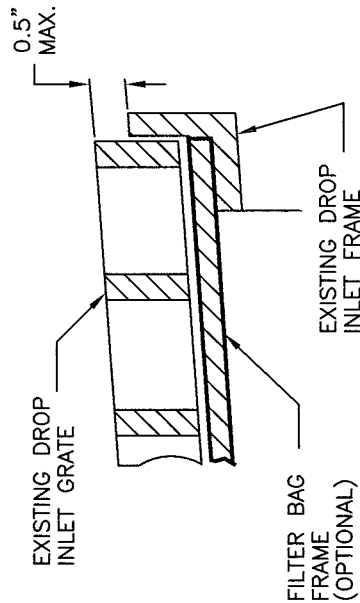
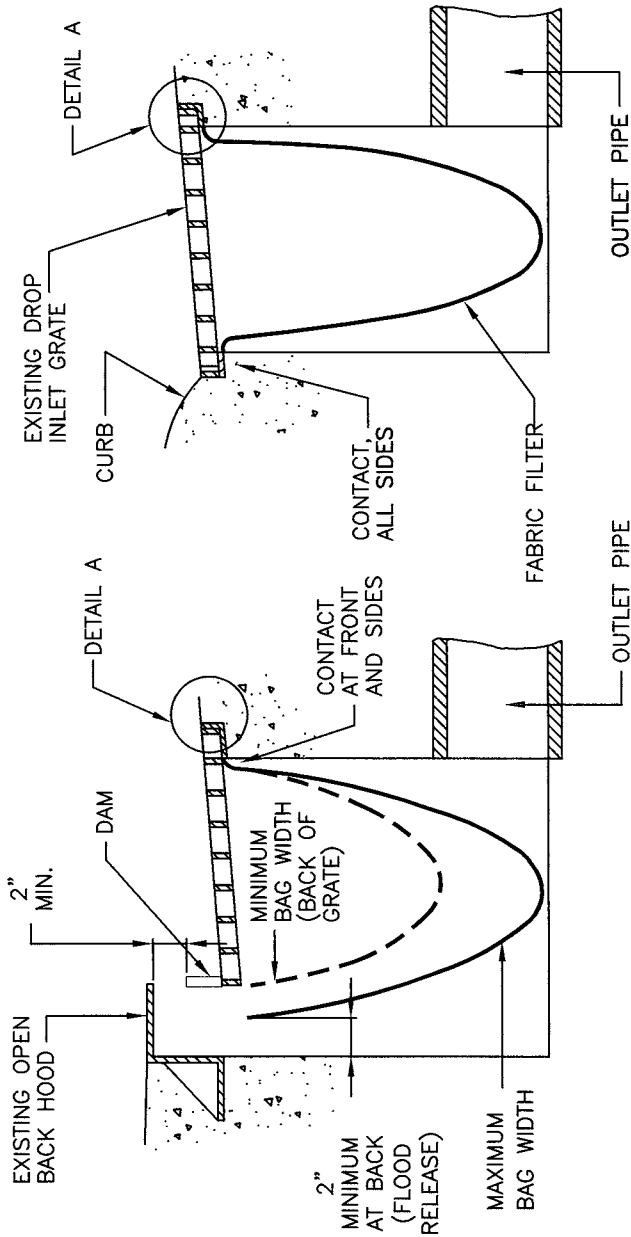

**DETAIL A**

**NOTES:**

1. THE MAXIMUM DRAINAGE AREA PER FILTER SHALL BE NO MORE THAN 2 ACRES.
2. THE FILTER BAG SHALL BE MANUFACTURED FROM UV RESISTANT POLYPROPYLENE, NYLON, POLYESTER, OR ETHYLENE FABRIC WITH A MINIMUM TENSILE STRENGTH OF 50 LBS PER LINEAL FOOT, AN EQUIVALENT OPENING SIZE NOT GREATER THAN A 20 SIEVE AND WITH A MINIMUM FLOW RATE OF 40 GALLONS / MINUTE / SQ FT.
3. THE FILTER BAG MAY BE SUSPENDED FROM OR HELD IN PLACE BY THE EXISTING INLET GRATE (OR OTHER APPROVED METHOD), PROVIDING NO MODIFICATION OR DAMAGE SHALL BE DONE TO THE INLET GRATE OR FRAME. THE INLET GRATE SHALL NOT BE CAUSED TO REST MORE THAN 0.5" ABOVE THE INLET FRAME (SEE DETAIL A).
4. THE FILTER BAG MAY EXTEND TO THE BOTTOM OF THE INLET BOX PROVIDED THE OUTLET PIPE IS UNOBSTRUCTED.
5. FLOWS SHALL NOT BE ALLOWED TO BYPASS THE BAG. THE BAG OR ITS FRAME SHALL CATCH FLOWS AT ALL SIDES OF THE INLET, EXCEPT AS SHOWN FOR FLOOD RELEASE.
6. INLET FILTER BAGS SHALL BE INSPECTED WEEKLY AND AFTER EACH RAINFALL DURING THE WET SEASON AND MONTHLY DURING THE DRY SEASON. SEDIMENT AND DEBRIS SHALL BE REMOVED BEFORE ACCUMULATIONS HAVE REACHED ONE THIRD THE DEPTH OF THE BAG. BAGS SHALL BE REPAIRED OR REPLACED AS SOON AS DAMAGE OCCURS.
7. AN APPROVED ALTERNATIVE ARE THE "GRATE MATES". THESE ARE PROVIDED WITH SLOTS THAT POLES CAN BE INSERTED FOR LIFTING OUT THE FILTER BAGS.

COUNTY OF YOLO  
PLANNING AND PUBLIC WORKS DEPARTMENT

STORM DRAIN INLET FILTER BAG

DATE: 08/05/08

SHEET # 2 OF 3

APPROVAL DATE  
*James Kallas* 28 AUG 08  
COUNTY ENGINEER No. C42401

DRAWING #:  
11-7  
NOT TO SCALE

GRAVEL BAG(S) OR OTHER ACCEPTED SEDIMENT CONTROL BMPs. PLACE BAGS TIGHT AGAINST FACE OF CURB.

BACK OF CURB

FACE OF CURB

LIP OF GUTTER

DRAINAGE INLET WITH FILTER BAG OR INLET FILTER

SEE NOTE 2

FLOW

45°

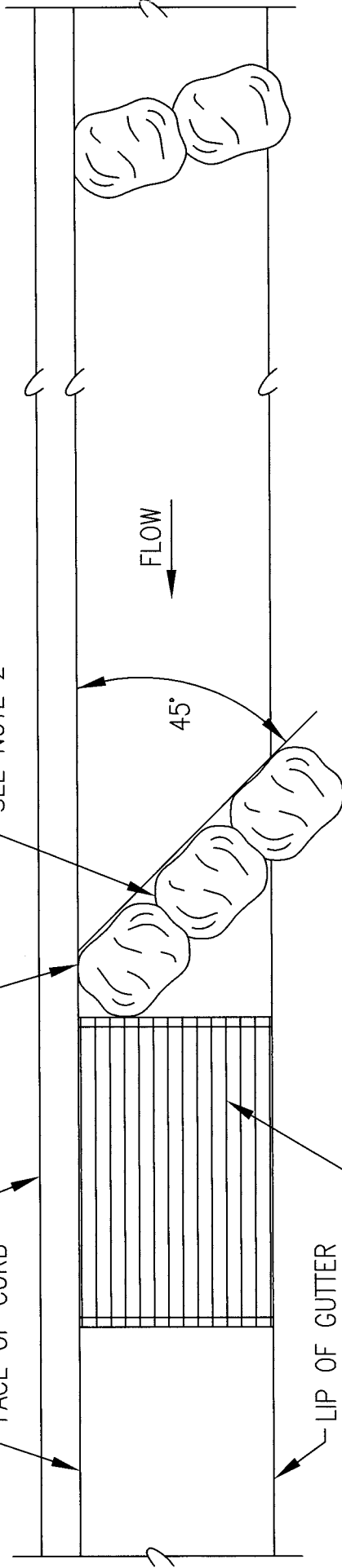

PLAN VIEW

NOTES:

1. SEDIMENT TRAPPED UPSTREAM OF SEDIMENT CONTROL BMPs SHALL BE REMOVED WEEKLY, PRIOR TO AND AFTER A RAINFALL EVENT.
2. PLACE BMPs TIGHTLY TOGETHER AT JOINTS TO PREVENT OR MINIMIZE SEEPAGE AT JOINTS.
3. REPAIR WASHOUTS AND OTHER DAMAGE AS NEEDED.
4. REMOVE BARRIER WHEN NO LONGER NEEDED.

COUNTY OF YOLO PLANNING AND PUBLIC WORKS DEPARTMENT	DATE: 08/05/08
INLET SEDIMENT CONTROL	SHEET # 3 OF 3
<i>James Kallas</i> COUNTY ENGINEER No. C42401	DRAWING #: 11--7 NOT TO SCALE
<i>28 AUG-08</i> APPROVAL DATE	

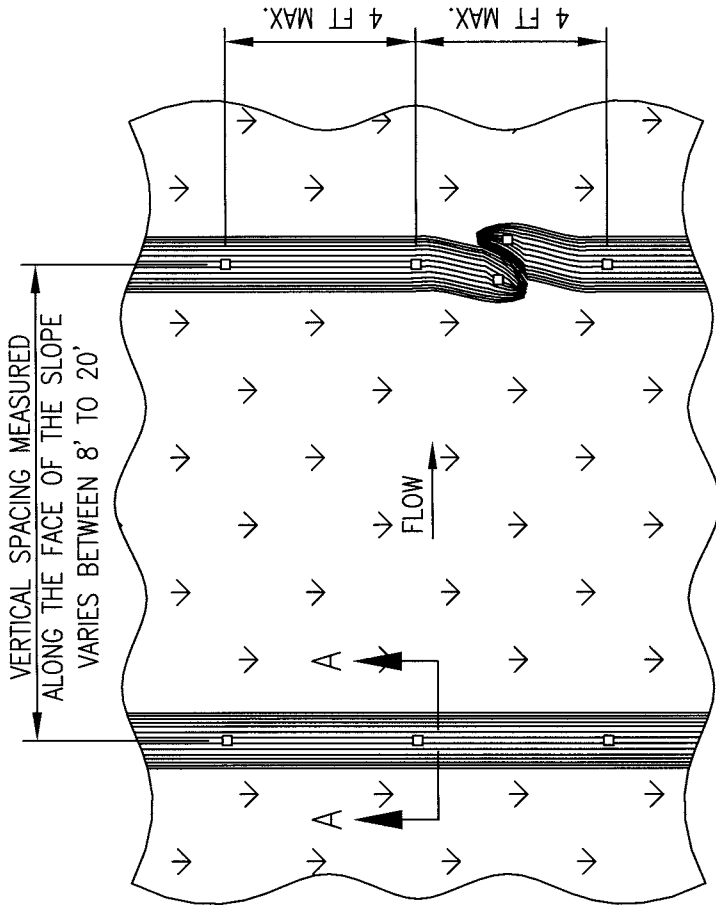

TYPICAL FIBER ROLL INSTALLATION

NOTES:

1. INSTALL FIBER ROLLS IN A ROW ALONG A LEVEL CONTOUR.
2. AT ENDS OF A ROW TURN THE LAST TWO FEET UP SLOPE SLIGHTLY.
3. FIBER ROLLS SHALL BE OVERLAPPED TIGHTLY AND STAKED AT THE JOINTS.
4. FIBER ROLLS WORK BEST IN CONJUNCTION WITH GOOD EROSION CONTROL BMPs.
5. INSPECT FIBER ROLLS WEEKLY, BEFORE AND AFTER A RAINFALL EVENT. REPAIR AND REPLACE AS NEEDED.

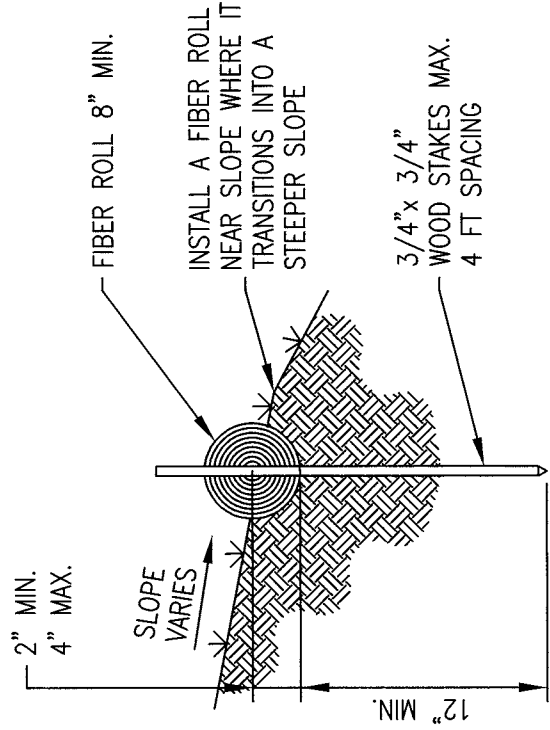

SECTION A - A

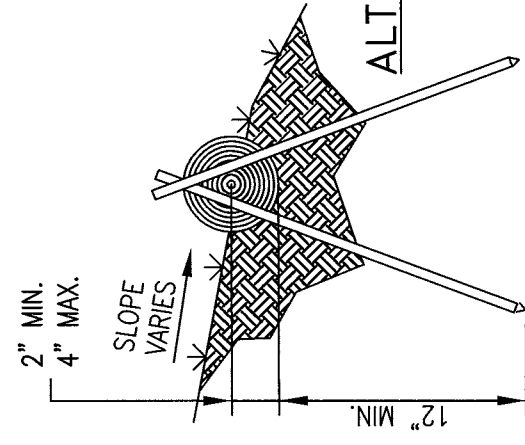

ALTERNATE STAKING DETAIL

COUNTY OF YOLO PLANNING AND PUBLIC WORKS DEPARTMENT	DATE: 08/05/08
FIBER ROLLS	SHEET # 1 OF 1
<i>Panos Kallias</i> COUNTY ENGINEER No. C42401	DRAWING #: 11-8 NOT TO SCALE
	APPROVAL DATE <i>28 Aug. 08</i>

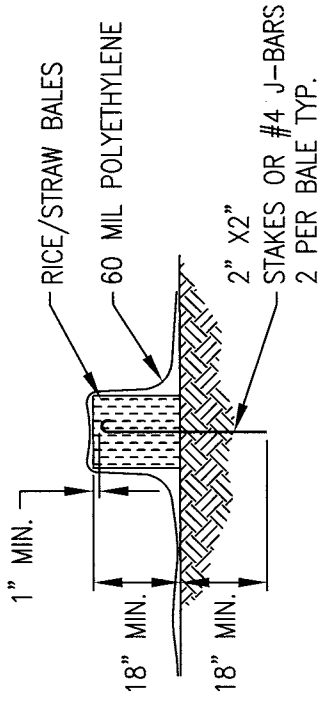
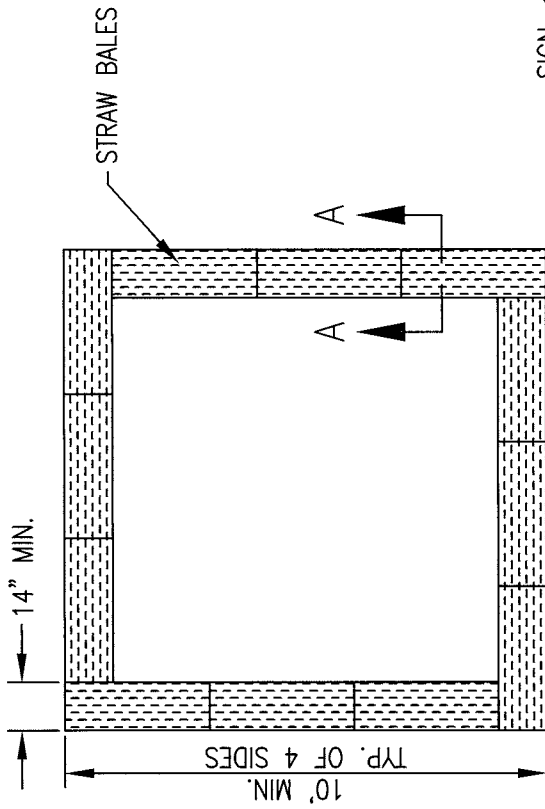

**SECTION A - A**

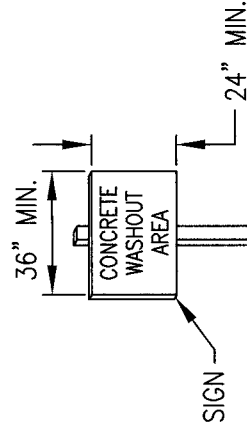

**BALE CONFIGURATION**

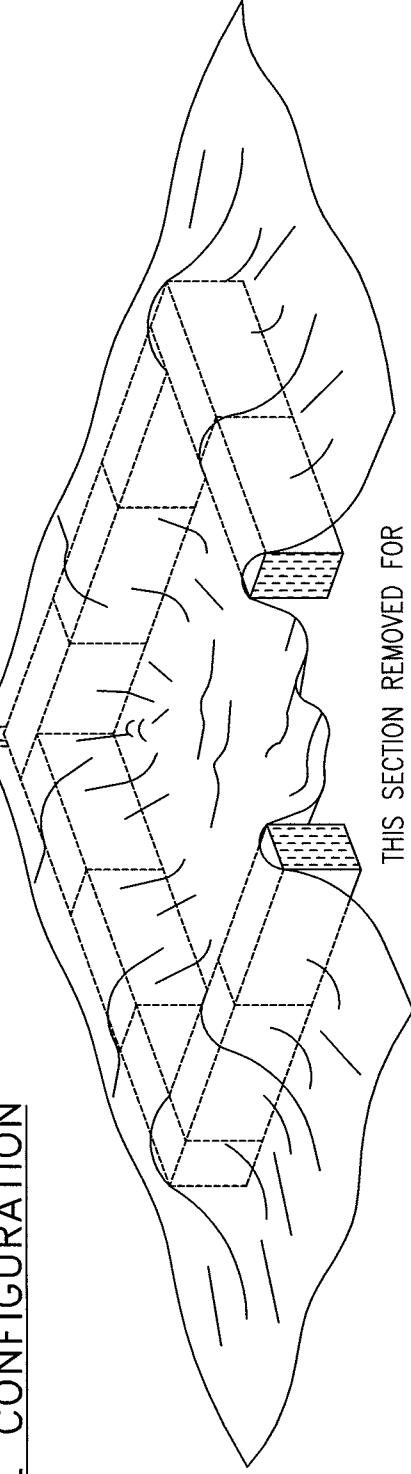

THIS SECTION REMOVED FOR GRAPHICAL REPRESENTATION ONLY. STRAW BALE PERIMETER SHALL BE CONTINUOUS.

**NOTES:**

1. FACE SIGN TOWARD NEAREST STREET OR ACCESS POINT.
2. CONCRETE WASHOUT SHALL BE LOCATED BEHIND THE CURB AND 50 FEET MINIMUM FROM DRAINAGE INLETS OR WATERCOURSES.
3. CONCRETE WASHOUT SHALL BE INSPECTED AND MAINTAINED TO PREVENT LEAKS OR OVERFLOWS.
4. WASHOUT MUST BE CLEANED, OR NEW ONE BUILT ONCE IT REACHES 75% CAPACITY.

COUNTY OF YOLO PLANNING AND PUBLIC WORKS DEPARTMENT	DATE: 08/05/08
CONCRETE WASHOUT	SHEET # 1 OF 1
<i>Pamela Rolles</i> COUNTY ENGINEER No. C42401	DRAWING #: 11-9 NOT TO SCALE
APPROVAL DATE 28 AUG. 08	

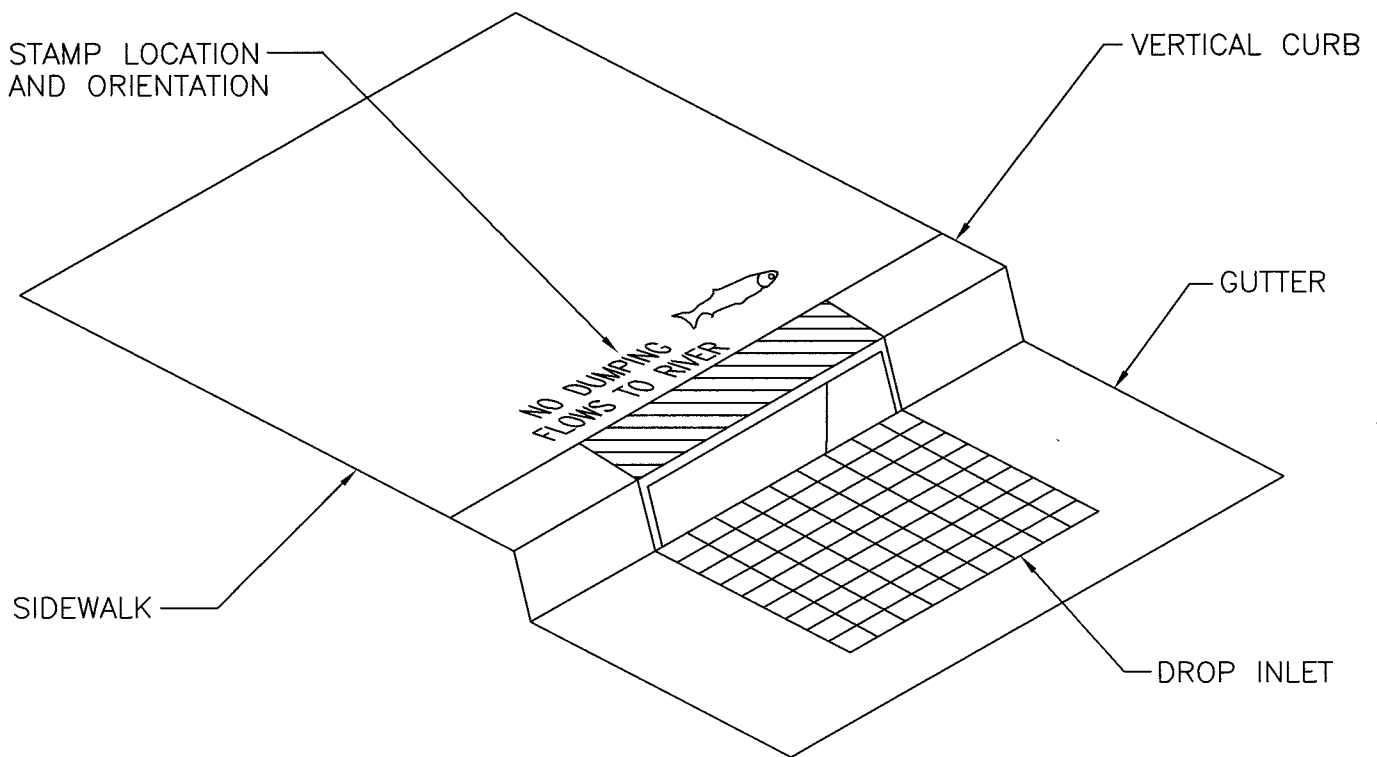

**NOTES:**

1. MESSAGE AND SYMBOL SHALL BE AS SHOWN ON DRAWING 11-10 SHEET 2 OR AS APPROVED BY THE COUNTY ENGINEER.
2. LETTERS SHALL BE 1.5 " IN HEIGHT. THE MESSAGE SHALL BE CENTERED ON THE BACK OF THE INLET.
3. CONCRETE SHALL BE STAMPED IN SUCH A WAY AS TO PROVIDE FOR A CLEAR AND LEGIBLE IMAGE. (APPROXIMATE DEPTH OF 1/4")
4. ALL STAMPS SHALL BE APPROVED BY THE DIRECTOR BEFORE BEING USED.
5. STAMP MAY BE PERMANENTLY CAST INTO CAST IRON FRAME OR PRE-CAST CONCRETE PORTIONS OF INLET.
6. WHERE RETROFITTING IS REQUIRED, AN EPOXIED PLACARD BEARING THE MESSAGE AND SYMBOL APPROVED BY THE COUNTY ENGINEER SHALL BE PERMANENTLY AFFIXED ON THE TOP OF THE ADJACENT CURB.

<b>COUNTY OF YOLO</b> PLANNING AND PUBLIC WORKS DEPARTMENT	DATE: 08/05/08
<b>STORMWATER QUALITY</b> <b>DROP INLET CONCRETE STAMP</b>	SHEET # 1 OF 2
<i>Parrish Kalkas</i> COUNTY ENGINEER No. C42401	DRAWING #: <b>11-10</b> NOT TO SCALE
28 AUG 08 APPROVAL DATE	



# STAMP MESSAGES AND SYMBOLS

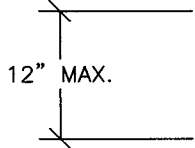
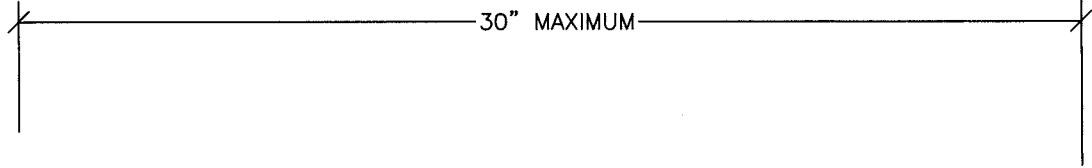

**NO DUMPING!  
FLOWS TO CREEK**

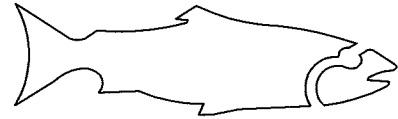

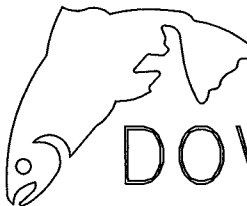
NO DUMPING  I LIVE  
DOWNSTREAM

NO DUMPING!  
FLOWS TO RIVER

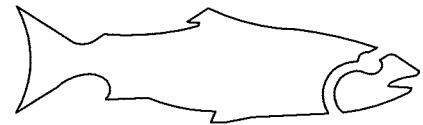

**NOTE:**

1. DIMENSIONS MAY VARY AMONG THE STAMP DESIGNS SHOWN BELOW, BUT SHALL NOT EXCEED THE MAXIMUM DIMENSIONS.

<b>COUNTY OF YOLO</b> PLANNING AND PUBLIC WORKS DEPARTMENT	DATE: 08/05/08
DROP INLET STAMP MESSAGES AND SYMBOLS	SHEET # 2 OF 2
 COUNTY ENGINEER No. C42401	28 AUG. 08 APPROVAL DATE
DRAWING #: <b>11-10</b> NOT TO SCALE	

## SECTION 12 SURVEY MONUMENTS

### **12-1 SURVEY MONUMENT REQUIREMENTS:**

- A. The Design Engineer<sup>1</sup> or Licensed Land Surveyor (LS) preparing the project mapping shall place survey monuments at the following locations:
1. Along the exterior of all mapped subdivisions, at all angle points, and on tangents, at distances not to exceed 1,000 feet. The monument shall be:
    - a.  $\frac{5}{8}$  inch diameter (minimum) solid steel bar at least 24 inches in length with aluminum or plastic cap and the LS number stamped thereon.
    - b.  $\frac{3}{4}$  inch inside diameter (minimum) galvanized iron pipe at least 24 inches in length with an aluminum or plastic cap and the LS number stamped thereon.
  2. At all lot corners:
    - a.  $\frac{1}{2}$  inch diameter solid steel bar at least 18 inches in length with aluminum or plastic cap and the LS number stamped thereon.
    - b.  $\frac{1}{2}$  inch inside diameter (minimum) galvanized iron pipe at least 18 inches in length with an aluminum or plastic cap and the LS number stamped thereon.
    - c. Cut crosses in the concrete curb or sidewalk shall be used instead of iron bar or pipe bar at the front of the property. All cut crosses shall be installed in accordance with Standard Drawing 12-2.
  3. In streets and alleys, standard street monuments in accordance with Standard Drawing 12-1 shall be installed at:
    - a. The beginning and end of all curves on the street centerlines or at the point of intersection of horizontal curves if the point is within the street pavement.
    - b. The intersection of all subdivision boundary lines with the street centerline.
    - c. At section and quarter corners and/or other historical land division corners that fall within the roadway.
    - d. Street monuments shall be placed at intermediate points on street centerline if sight lines between monuments can be potentially obstructed by landscaping or improvements on private property.
    - e. Standard street monuments are not required when the distance between sets of monuments is less than 100 feet, except that street intersection monuments are always required. Any such monument eliminated shall be replaced with a suitable iron pipe or bar in the roadway.

---

<sup>1</sup> A Registered Civil Engineer registered prior to December 31, 1981 is licensed to practice land surveying..

4. Monuments of the type required at such other locations as required by the County Surveyor or County Engineer.
- B. The Design Engineer shall show the location and character of all survey monuments within the construction area and place a note on all construction plans stating that the Contractor is responsible for the protection of all existing monuments and other survey markers in accordance with Section 8771 of the Land Surveyor's Act.

<b>Standard Drawings</b>		
<b>Section 12 – Survey Monuments</b>		
<b>Drawing</b>	<b>Sheets</b>	<b>Description</b>
12-1	1	Monument Box
12-2	1	Property Line Marker

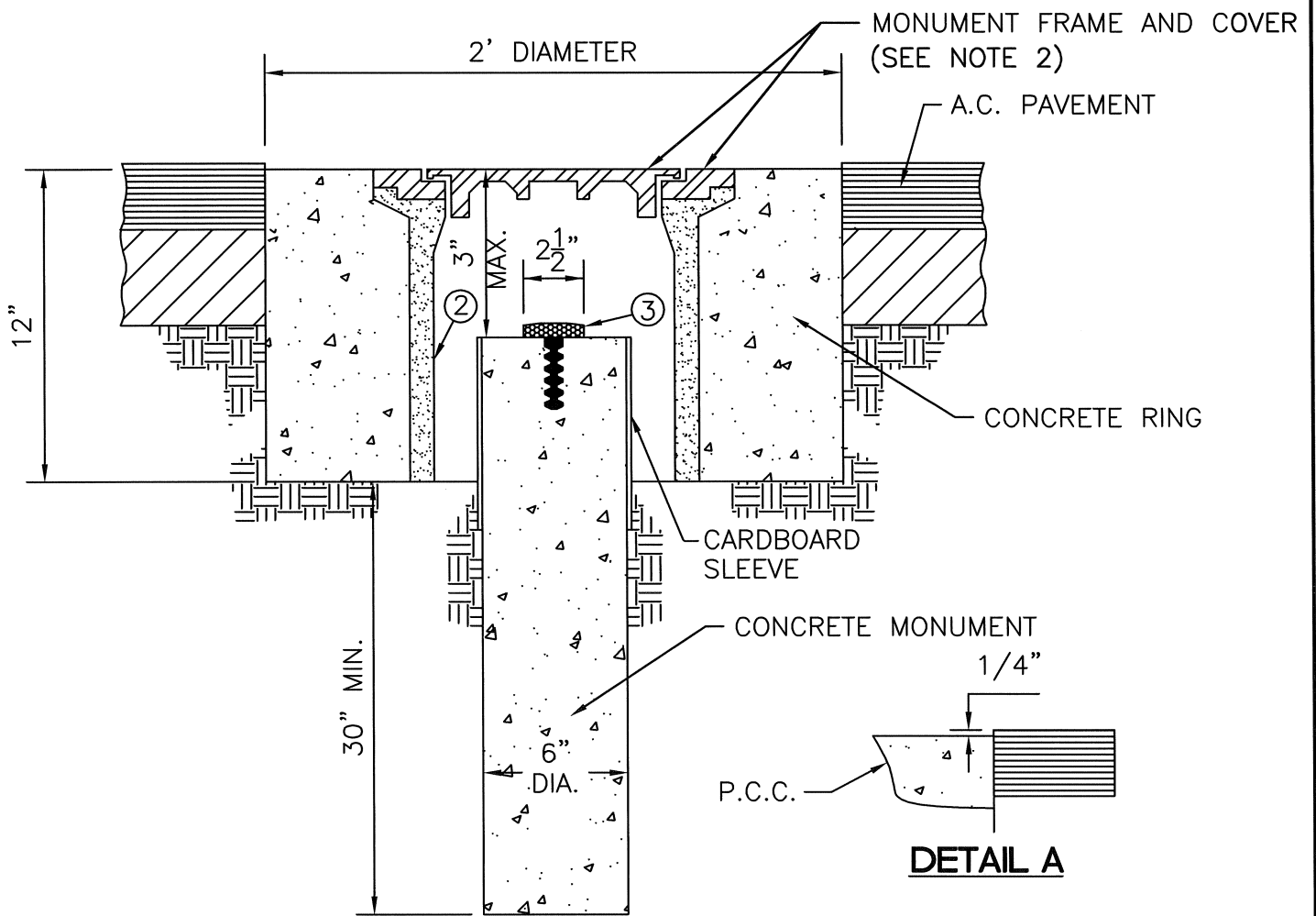

**MONUMENT CROSS SECTION**

**NOTES:**

1. CONCRETE SHALL BE CLASS "A", 6-SACK PORTLAND CONCRETE. THE PRECAST BOX SHALL BE SET IN CONCRETE 1/4" BELOW THE PAVEMENT.
2. MONUMENT FRAME AND COVER SHALL BE CHRISTY G5 TRAFFIC VALVE BOX OR APPROVED EQUAL. LID TO BE MARKED "MONUMENT".
3. SURVEY MARKER SHALL BE LIETZ 8134-16, SERVICE CO. 287-C OR APPROVED EQUAL.
4. THE C.E. OR L.S. NUMBER MUST APPEAR ON THE SURVEY MARKER.
5. MARK REFERENCE POINT WITH A "+".

<b>COUNTY OF YOLO</b> PLANNING AND PUBLIC WORKS DEPARTMENT	DATE: 08/05/08
<b>MONUMENT BOX</b>	SHEET # 1 OF 1
<i>Ramos Kollas</i> COUNTY ENGINEER No. C42401	28 AUG. 08 APPROVAL DATE
	DRAWING #: <b>12-1</b> NOT TO SCALE

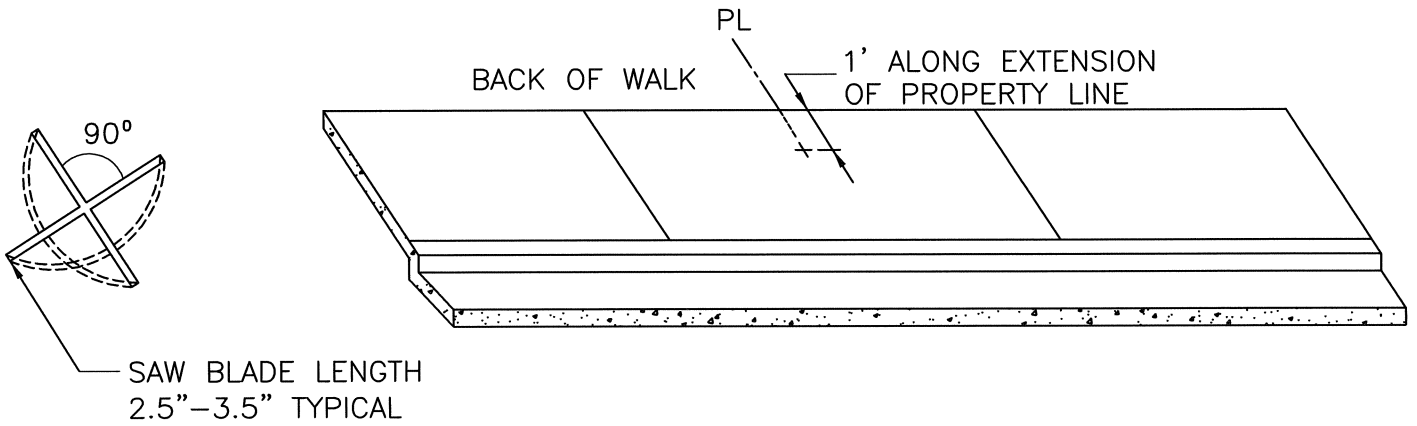

USE 3"–4" DIAMETER DIAMOND BLADE  
CIRCULAR SAW TO CUT CROSS AT  
PROPERTY LINE AS SHOWN

### SAW CUT CROSS

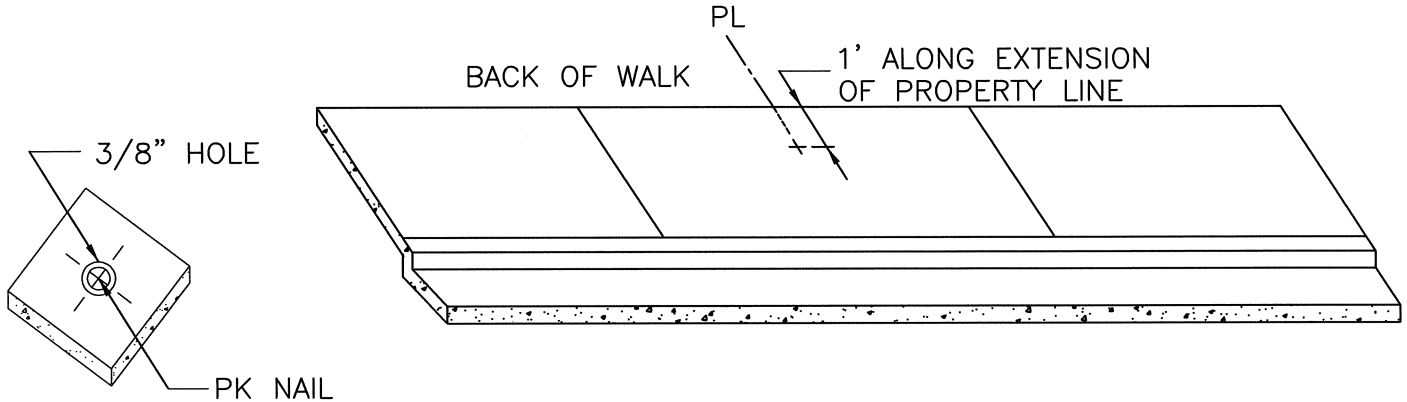

DRILL 3/8" DIAMETER HOLE FILL  
WITH EPOXY AND INSTALL 3/4"  
LONG PK NAIL SO TOP OF HEAD  
IS FLUSH WITH WALK.

### NAIL SET IN EPOXY

<b>COUNTY OF YOLO</b> PLANNING AND PUBLIC WORKS DEPARTMENT		DATE: 08/05/08
<b>PROPERTY LINE MARKER</b>		SHEET # 1 OF 1
<i>Parvus Kakkas</i> COUNTY ENGINEER No. C42401	28 AUG - 08 APPROVAL DATE	DRAWING #: 12-2 NOT TO SCALE