



Compact Mobile Food Operations Construction Guidelines

Unpackaged Food

INTRODUCTION:

On September 23, 2022, Senate Bill 972 (SB 972) was signed by the Governor and becomes effective January 1, 2023. This bill modifies the California Retail Food Code (CRFC) to relax some structural and operational requirements for lower risk sidewalk food vending operations. SB 972 created a new category of Mobile Food Facilities termed Compact Mobile Food Operation (CMFO)

This document provides information on the structural requirements based on the CRFC for CMFO's that handle unpackaged foods. The type of food service for these types of CMFO's is restricted to Limited Food Preparation as defined in the California Retail Food Code section 113818. Examples of menu items that easily fit within Limited Food Preparation include but are not limited to: hot dogs, shaved ice, roasted nuts, popcorn, or churros.

A valid Health Permit is required for CMFO's that handle unpackaged food. Plan submittal is required for the review of any proposed CMFO and plans must be approved before a Health Permit will be issued. Use the Plan Submittal Checkbox (starting on Page 4) to ensure that all necessary information is included as part of the plan submittal.

DEFINITIONS:

- A. Commissary** means a health permitted food facility that services mobile food facilities.
- B. Compact Mobile Food Operation (CMFO)** means an unenclosed mobile food facility that operates from an individual or from a pushcart, stand, display, pedal-driven cart, wagon, showcase, rack, or other nonmotorized conveyance. An Unpackaged Compact Mobile Food Operation (CMFO) is a non-motorized Mobile Food Facility that is restricted to Limited Food Preparation as defined in the California Retail Food Code section 113818. Examples of menu items that easily fit within Limited Food Preparation include, but are not limited to: hot dogs, shaved ice, roasted nuts, sliced fruit, boiled corn, popcorn, or churros.
- C. Food Compartment** means an enclosed space, including, but not limited to, an air pot, blender, bulk dispensing system, covered chafing dish, and covered ice bin, with all of the following characteristics:
- (a) The space is defined by a physical barrier from the outside environment that completely encloses all food, food-contact surfaces, and the handling of nonprepackaged food.
 - (b) All access openings are equipped with tight-fitting closures, or one or more alternative barriers, that effectively protect the food from contamination, facilitate safe food handling, while minimizing exposure to the environment.
 - (c) It is constructed from materials that are nontoxic, smooth, easily cleanable, and durable and is constructed to facilitate the cleaning of the interior and exterior of the compartment.
- C. Limited Food Preparation** is limited to:
- Heating, frying, baking, roasting, popping, shaving of ice, blending steaming or boiling of hot dogs, or assembly of nonprepackaged food
 - Dispensing and portioning of non-potentially hazardous food or dispensing and portioning for immediate service to a customer of food that has been held at the required temperatures.
 - Slicing and chopping of non-potentially hazardous food or produce that has been washed at an approved facility
 - Slicing and chopping of food on a heated cooking surface during the cooking process

- Juicing or preparing beverages that are for immediate service, in response to an individual consumer order, that do not contain frozen milk products
- Hot and cold holding of food that has been prepared at an approved permanent food facility
- Reheating of food that has been prepared at an approved permanent food facility

D. Potentially Hazardous Food (PHF) means a food that requires time or temperature control to limit pathogenic micro-organism growth or toxin formation. Examples include tamales, sliced melons, burritos, ice cream sandwiches.

UNPACKAGED CMFO REQUIREMENTS:

REQUIREMENTS	Not handling raw meats, raw poultry, or raw fish	Handling raw meats, raw poultry, or raw fish
Health Permit	Yes	Yes
Plan Check	Yes	Yes
Hand sink	Yes	Yes
Warewashing sink	No	Yes
Water heater	No	Yes
Mechanical refrigeration for PHF	Yes	Yes
Commissary required	Yes	Yes

PLAN SUBMITTAL PROCESS:

This packet can be used to draw your proposed CMFO operation and submit to your local Environmental Health Department for review and approval. You may draw your own plans using this document as guidance, but all items listed in this document must be represented in your submitted plans. Plans must be reviewed and approved prior to the issuance of a health permit. Operators are required to have all plans approved prior to the construction of the CMFO to prevent any additional costs that would be incurred if modifications are needed should changes be noted on the plans. All items provided on the following pages are required unless otherwise noted.

1. Submit complete, easily readable plans that are drawn to scale and include equipment specifications along with the applicable plan review fee. Drawings must show all four (4) sides and the top view of the CMFO and a complete plumbing diagram.
2. Submit proposed menu and standard operating procedures (for food handling and the cleaning and sanitizing of food-contact surfaces and utensils).
3. Once approved, submit an application for a Health Permit along with applicable fees to operate.

See the Plan Submittal Check List for a list of required information that must be submitted.

- **Page 4-6** – Check each box indicating that the item is completed on the plans.
- **Page 6** – Sign and date acknowledging the understanding of CMFO limitations and certifying that all information provided is accurate.
- **Page 7** – List all food items, finish materials, equipment information.
- **Page 8 – 13** - Complete all diagram templates. Additional sheets may be provided if necessary.
- **Page 14** – Standard Operational Procedures for CMFO
- **Page 14 - 26** – Examples are provided on how to properly complete all required sections.
- **Page 27 - 30** – Plumbing Note Examples

COMPACT MOBILE FOOD OPERATION PERMIT PROCESS



1. SUBMITTAL

Submit completed packet for review. Refer to checklist on items needed for packet.



2. PLAN REVIEW

Packet will be reviewed for accuracy and completeness.



3. INSPECTION

After written approval, inspection will be scheduled. Refer to inspection schedule checklist



4. APPROVAL

Once final inspection has passed and been completed, last pending documents are processed and permit to operate is provided. Refer to supplemental documents checklist.



Plan Submittal Check List:

CHECK BOX ✓	ITEMS TO PROVIDE ON PLANS
	Menu or list of all items being sold.
	Each piece of equipment and the location on the CMFO.
	Make and model of all equipment. Attach specification sheets.
	Completed table listing the material of finishes of the interior, exterior, and/or storage areas of the CMFO. (See page 14 example)
	Indicate equipment power source: Battery Propane Tank
	First Aid Kit.
	10 BC-rated fire extinguisher (required if electrical or gas equipment is used).

	Identification on the CMFO: Name of Facility, City, State, and Zip Code of the permit holder. <i>Lettering of the Facility Name: 3" high minimum</i> <i>Lettering of the City, State, and Zip Code of the permit holder: 1" high minimum</i>
	Completed plan check application .
	Completed Standard Operational Procedures for CMFOs .
	Completed commissary letter . <i>NOTE: A signed copy by the commissary permit holder is required at the time of inspection/permitting.</i>

CHECK BOX ✓	SINK AND PLUMBING REQUIREMENTS	
	CMFO NOT HANDLING RAW MEATS, RAW POULTRY, OR RAW FISH	CMFO HANDLING RAW MEATS, RAW POULTRY, OR RAW FISH
	Handwashing Sink Minimum dimensions: 9" wide X 9" long X 5" deep. Warm water not required.	Handwashing Sink Minimum dimensions: 9" wide X 9" long X 5" deep. Warm water required
	Warewashing Sink IS NOT REQUIRED if spare clear utensils are provided. <i>NOTE: All utensils/equipment must be washed and sanitized on a daily basis at the commissary and the CMFO must be equipped with an adequate supply of spare preparation and serving utensils when in use.</i>	Warewashing Sink IS REQUIRED An integral 3-compartment warewashing sink must be provided that meets the following requirements: Each sink compartment must have minimum dimensions: 12" wide X 12" long X 10" deep OR 10" wide X 14" long X 10" deep. The warewashing sink must be stainless steel and equipped with dual integral drainboards that are at least the size of one of the compartments.

	<p>Potable Water Tanks Minimum 5 gallons for handwashing.</p>	<p>Potable Water Tanks Minimum 20 gallons required: 5 gallons for handwashing and 15 gallons for warewashing Additional capacity is needed if product water is needed. All potable water tanks shall be manufactured and listed to NSF standards for potable water.</p>
	<p>Water Heater Not required</p>	<p>Water Heater Handwashing sink - a water heater with minimum 0.5-gallon capacity or an instantaneous heater is required and must be capable of supplying a minimum of 100°F running water. Warewashing sink - a minimum 4-gallon capacity water heater is required and must be capable of supplying a minimum of 120°F running water. <i>NOTE: Steam table reservoirs cannot be used as a water heater.</i></p>

	<p>Wastewater Tanks Minimum capacity is 150% greater than the total capacity of provided potable water tanks. Where an ice bin is provided for storage, display or service of food/beverage, an additional holding tank capacity equal to one-third the volume of the bin must be provided. Multiple removeable tanks may be used.</p>	
	<p>Plumbing Lines Potable water lines must be listed to NSF 61 for potable water. Waste lines cannot be the same color as the hoses for potable water. Typical potable water line colors are clear, white, or blue. Typical wastewater lines are black or grey.</p>	
	<p>Water Pump Pump for potable water supply must be listed to NSF standards. No pump will be approved for drainage. All liquid waste drainage must be done by gravity.</p>	

CHECK BOX ✓	EQUIPMENT
	<p>Certified Equipment All equipment must be certified for sanitation (e.g. NSF, ETL, CSA, UL, NEMKO, etc.).</p>
	<p>Mechanical Refrigeration Required if handling potentially hazardous foods, capable of holding foods at or below 41°F.</p>
	<p>Hot-holding Unit Required if hot holding potentially hazardous foods, capable at hot holding at or above 135°F.</p>
	<p>Storage compartments clean utensils and for the orderly storage of food items</p>

Food Compartment

Food preparation must be done within a food compartment.

Food compartments must be constructed from materials that are nontoxic, smooth, easily cleanable, and durable and constructed to facilitate the cleaning of the interior and exterior of the compartment.

Food compartments must be heat resistant and built in a manner that does not contaminate food during normal use. (See page xx for samples)

Typical equipment requiring a compartment includes, but is not limited to: hot dog steamer, Italian ice serving freezer, fryer, griddle, and preparation table.

Typical equipment NOT requiring a compartment includes, but is not limited to: espresso machine, microwave, ovens, air pots, blenders.

SIGNATURE AND ACKNOWLEDGEMENT

I certify that my operation on this CMFO does not and will not include any of the following: thawing, cooling of cooked potentially hazardous foods (PHF), grinding raw ingredients or PHF, reheating PHF for hot holding (except steamed or boiled hot dogs, and tamales in the original inedible wrapper), hot holding non-prepackaged PHF (except steamed or boiled hot dogs, and tamales in the original inedible wrapper or food prepared at an approved permanent food facility), washing of foods, cooking PHF for later use, and any operation requiring licensing through the California Department of Food and Agriculture, Milk and Dairy Branch. **Health & Safety Code, Section 113818**

I declare under penalty of perjury that to the best of my knowledge and belief, the description of use and information contained on this application and plans are correct and true. I hereby consent to all necessary inspections made pursuant to law and incidental to the issuance of this review and the operation of this business. I also agree to conform to all conditions, orders, and directions, issued pursuant to the California Health and Safety Code, and all applicable County and City Ordinances. I understand that if the plans are incomplete due to a lack of any of the required information, the plans will be rejected and upon resubmission, a plan recheck fee will be charged. I am aware that plan check fees are not fully refundable once plans are reviewed. Plans are valid for one year after stamp of approval and must be restamped within 60 days of expiration or they will be purged.

Authorized Signature: _____ Date: _____

OFFICE USE ONLY**SCHEDULING INFORMATION****APPROVAL STAMP**

Plans are approved by the Department of Environmental Health and Quality, Food and Housing Division and contingent on the final inspection.

Your inspection is scheduled for: _____ Time: _____

Assigned Specialist: _____

Contact Information: _____

LIST OF MENU/ITEMS BEING SOLD

FINISH MATERIALS

**Raw wood not permitted to be used as exterior CMFO material*

LOCATION/EQUIPMENT	MATERIAL
Exterior of CMFO	
Interior of CMFO	
Food Storage Area	
Food Preparation Compartment	
Other:	

FOOD SERVICE EQUIPMENT LIST

EQUIPMENT	MANUFACTURER	MODEL

POWER/GAS PLAN

Select all applicable options and fill in the blanks for each one:

- DC Battery* (Quantity ___)
**Requires Inverter*
- AC Battery (Quantity___)
- Propane Tank (Pounds ___; Quantity ___)

LEFT SIDE VIEW OF CMFO- Internal View Showing Equipment Placement

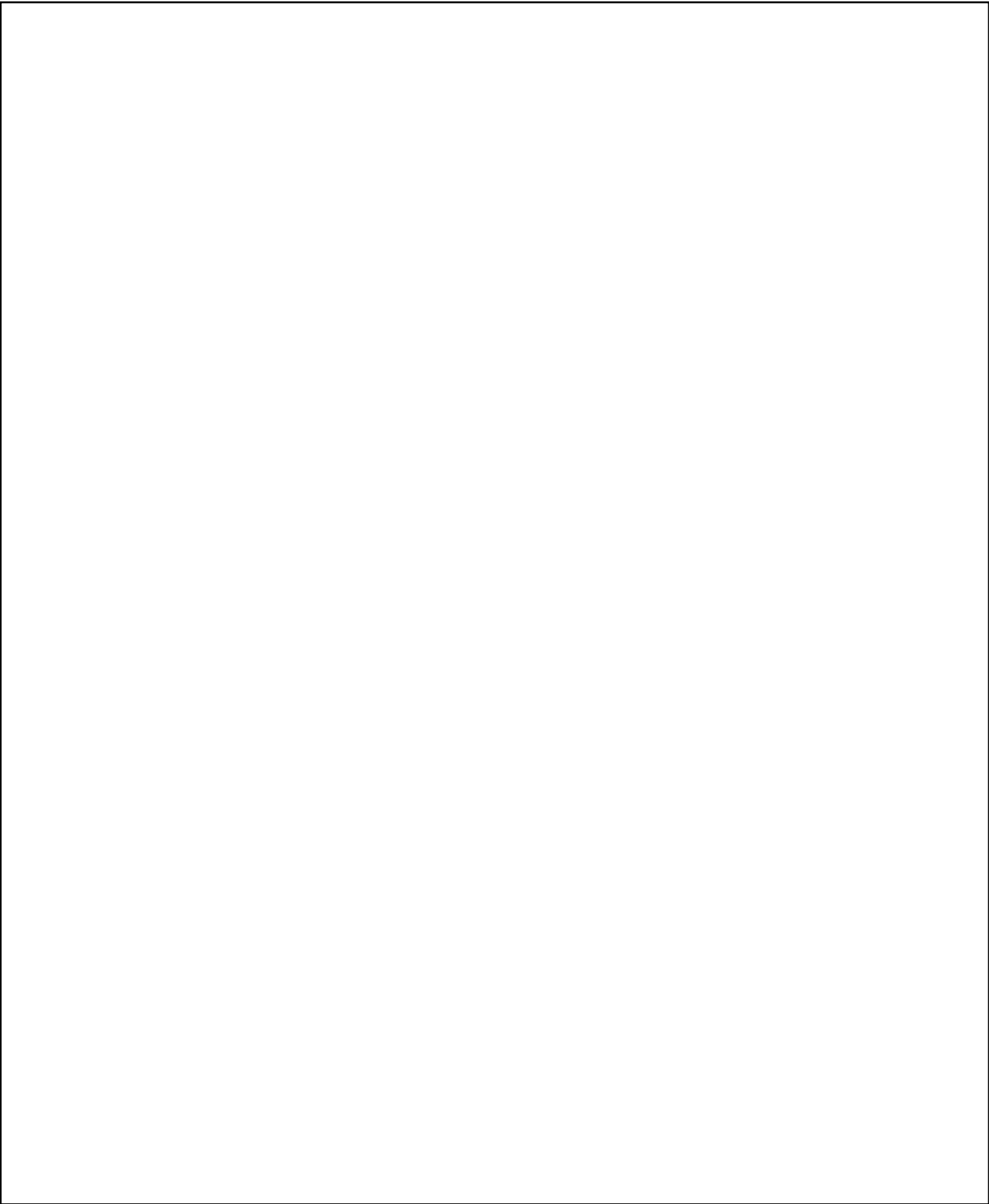

RIGHT SIDE VIEW OF CMFO- Showing Customer Side

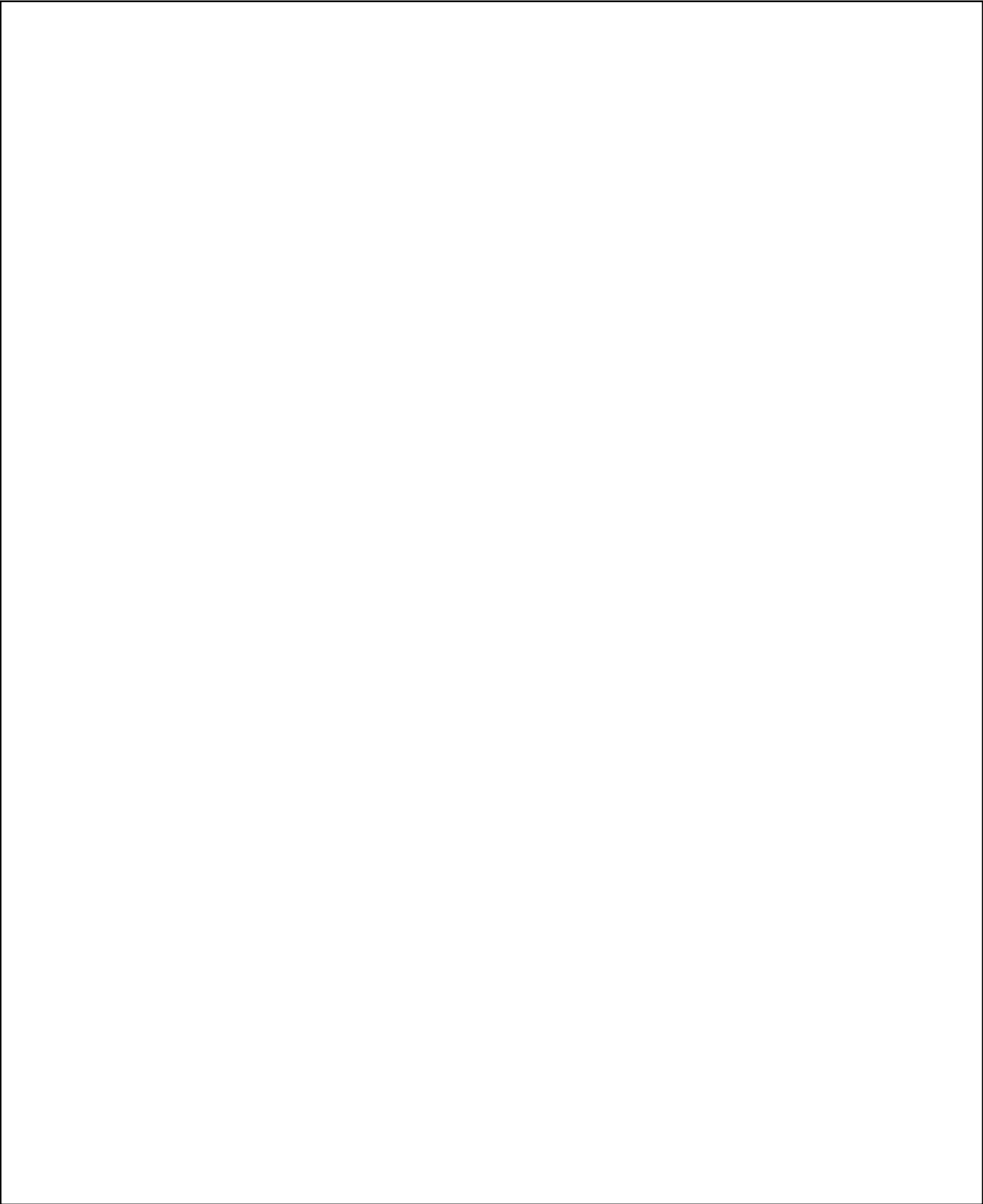

TOP SIDE VIEW OF CMFO

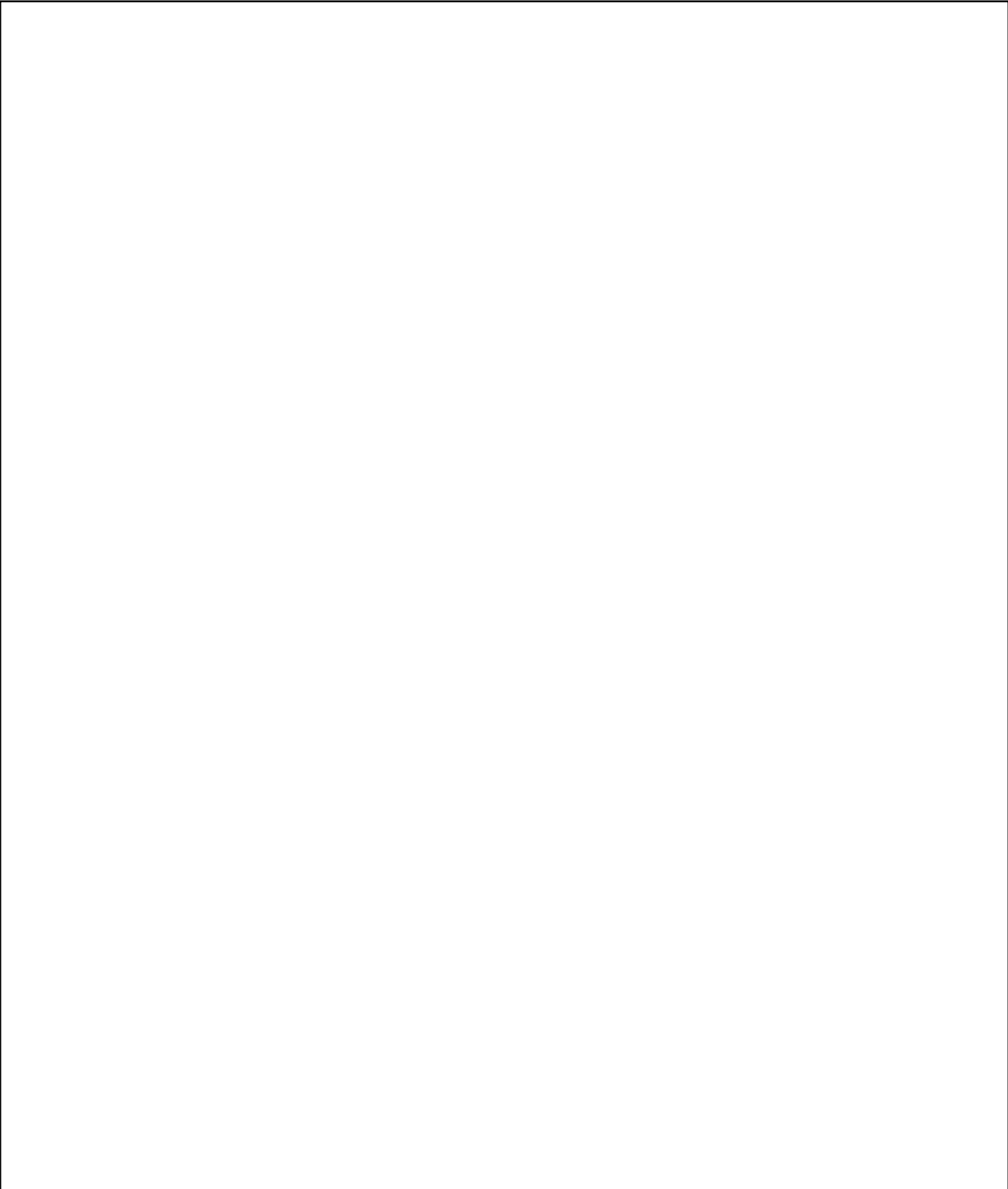

LEFT END FROM CUSTOMER SIDE VIEW OF CMFO



RIGHT END FROM CUSTOMER SIDE VIEW OF CMFO

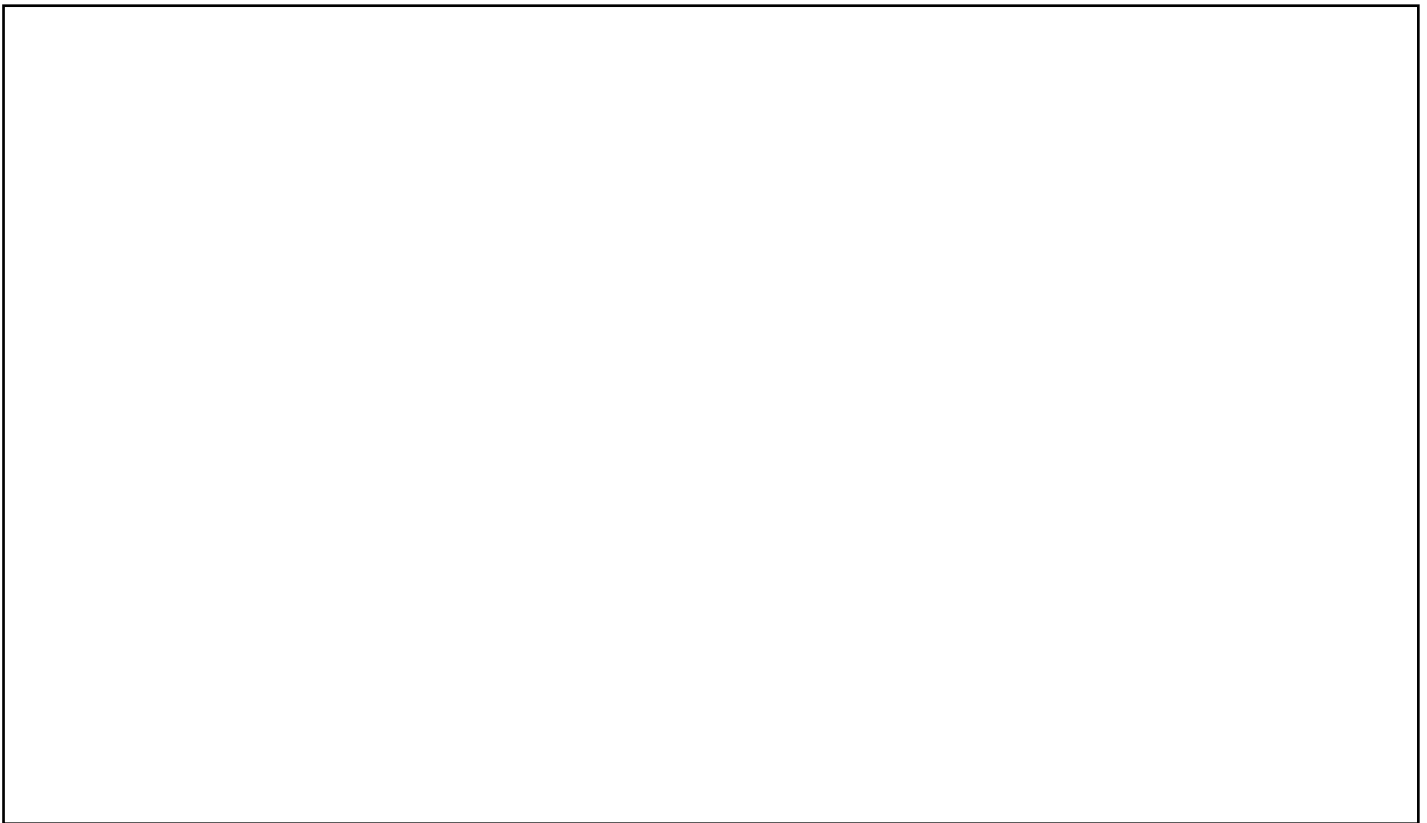

PLUMBING DIAGRAM WITH 3 COMPARTMENT SINK

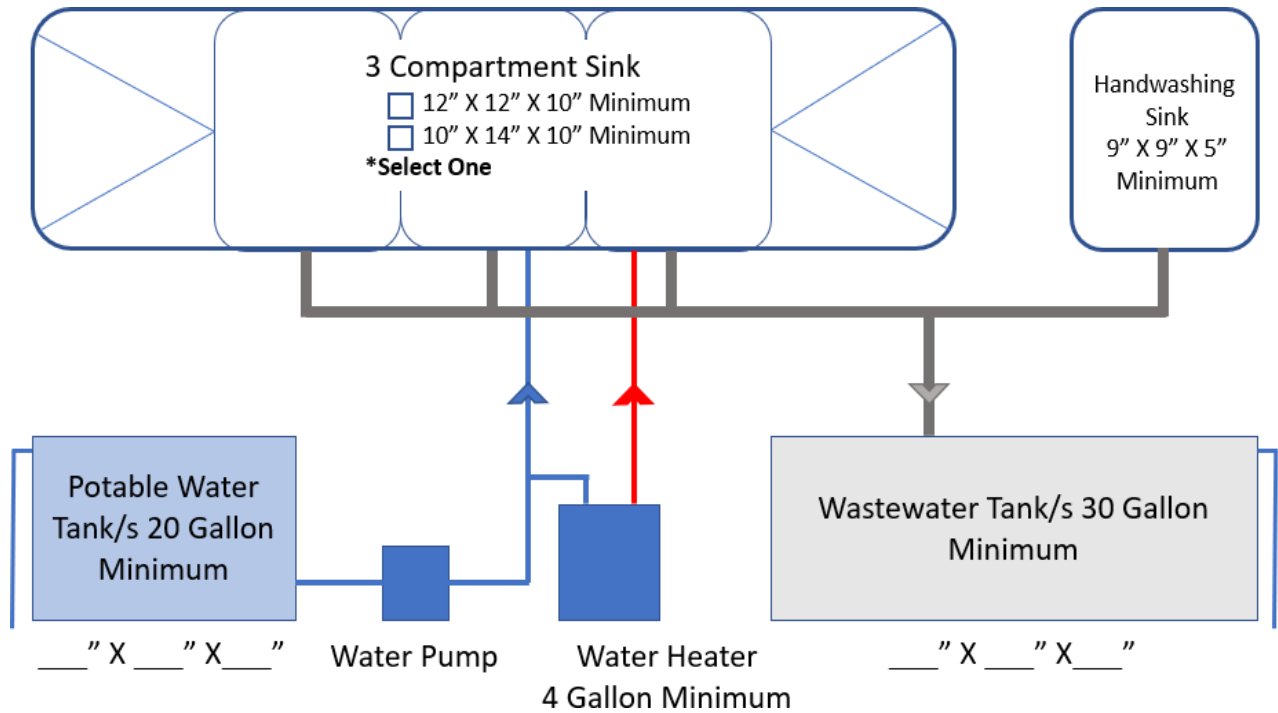

Plumbing Notes:

- All plumbing lines shall be connected to the tanks with watertight seals.
- Potable water lines, couplings, and valves shall be listed to NSF standards for drinking water.
- Potable water tanks and wastewater tanks mounted in the CMFO shall have an air vent overflow installed draining outside of the CMFO in a downward direction covered with 16 mesh per square inch screen.
- Tanks may be removeable. If they are not removeable, they must be equipped with a fill line that has a nonthreaded quick disconnect coupler. They must also be installed sloped towards a drainage outlet equipped with a valve.
- Tanks and hose inlets and outlet fittings shall be protected with a cap and keeper chain, quick disconnect, or closed cabinet when not in use.
- Waste lines must be a different color than the lines for potable water.
- The 3-compartment sink must be stainless steel and equipped with dual integral drainboards that are at least the size of one of the compartments.

WATER PUMP MANUFACTURER AND MODEL: _____

WATER HEATER MANUFACTURER AND MODEL: _____

PLUMBING DIAGRAM WITHOUT 3 COMPARTMENT SINK

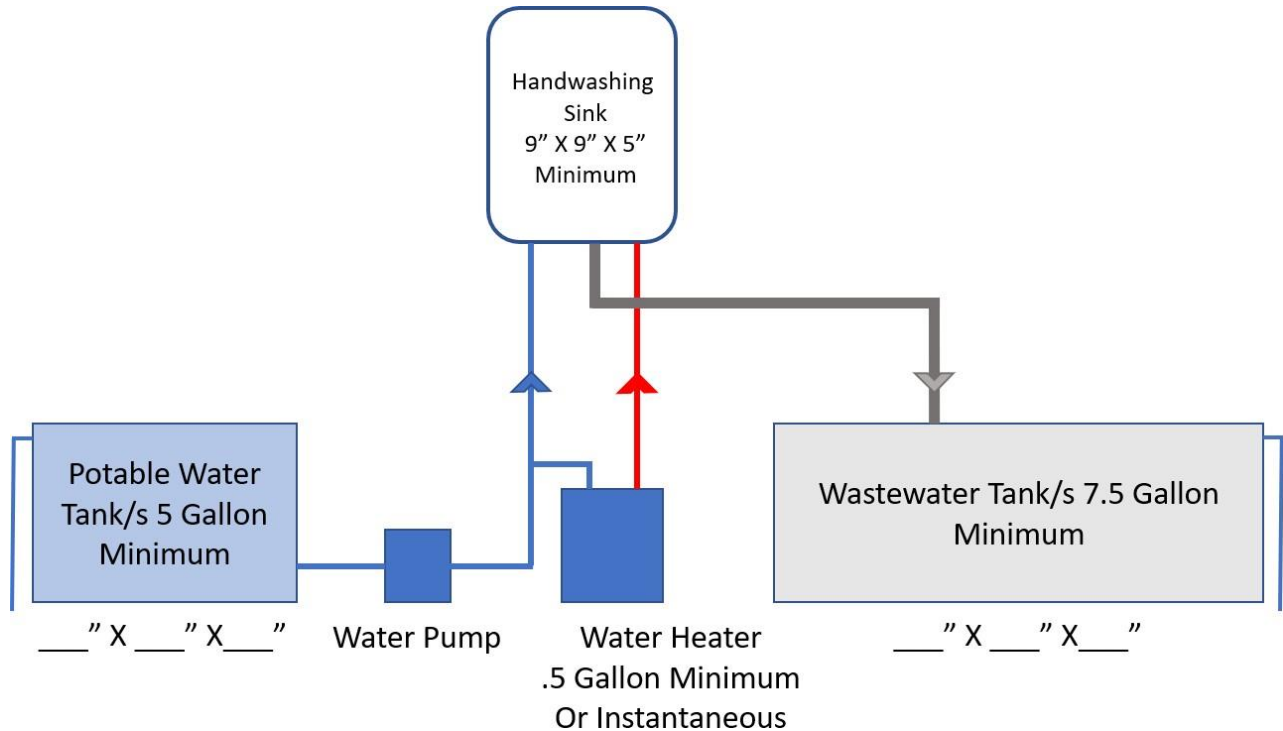

Plumbing Notes:

- Water heater is optional.
- All plumbing lines shall be connected to the tanks with watertight seals.
- Potable water lines, couplings, and valves shall be listed to NSF standards for drinking water.
- Potable water tanks and wastewater tanks mounted in the CMFO shall have an air vent overflow installed draining outside of the CMFO in a downward direction covered with 16 mesh per square inch screen.
- Tanks may be removeable. If they are not removeable, they must be equipped with a fill line that has a nonthreaded quick disconnect coupler. They must also be installed sloped towards a drainage outlet equipped with a valve.
- Tanks and hose inlets and outlet fittings shall be protected with a cap and keeper chain, quick disconnect, or closed cabinet when not in use.
- Waste lines must be a different color than the lines for potable water.

WATER PUMP MANUFACTURER AND MODEL: _____

WATER HEATER MANUFACTURER AND MODEL: _____

Standard Operational Procedures for Unpackaged Compact Mobile Food Operations

Compact Mobile Food Operation Name: _____ **Health Permit Number:** _____

Hours of Operation	Time	Mon	Tue	Wed	Thur	Fri	Sat	Sun
Start:		<input type="checkbox"/> am	<input type="checkbox"/> am	<input type="checkbox"/> am	<input type="checkbox"/> am	<input type="checkbox"/> am	<input type="checkbox"/> am	<input type="checkbox"/> am
		<input type="checkbox"/> pm	<input type="checkbox"/> pm	<input type="checkbox"/> pm	<input type="checkbox"/> pm	<input type="checkbox"/> pm	<input type="checkbox"/> pm	<input type="checkbox"/> pm
End:		<input type="checkbox"/> am	<input type="checkbox"/> am	<input type="checkbox"/> am	<input type="checkbox"/> am	<input type="checkbox"/> am	<input type="checkbox"/> am	<input type="checkbox"/> am
		<input type="checkbox"/> pm	<input type="checkbox"/> pm	<input type="checkbox"/> pm	<input type="checkbox"/> pm	<input type="checkbox"/> pm	<input type="checkbox"/> pm	<input type="checkbox"/> pm

Location Of Operation: _____ **CITY:** _____, **CA ZIP:** _____

Business Owner Name: _____ **PHONE:** _____

FAX: () _____ **EMAIL:** _____

Mailing Address: _____ **City:** _____ **STATE:** _____ **ZIP:** _____

1. Indicate the location where you will store food at the end of the day.

Food Stored at: _____ City: _____, CA Zip _____
 Street No. Street Name

2. Indicate the location where you will store the Compact Mobile Food Operation (CMFO) unit at the end of the day.

CMFO Stored at: _____ City: _____, CA Zip: _____
 Street No. Street Name

3. Name of business providing restroom facility during hours of operation:

Business location: _____ City: _____, CA Zip: _____
 Street No. Street Name

4. Describe the procedures you will use to clean and sanitize food contact surfaces, equipment, and utensils during working hours and at the commissary.

	During working hours	At the Commissary
Clean		
Sanitize		

5. Indicate the specific sanitizer or sanitizing method that you will use by checking the box below:

- Contact with a solution of 100 ppm (parts per million) available chlorine for at least 30 seconds.
 - Contact with a solution of 200 ppm available quaternary ammonium for at least one minute.
- Check the option you will use: Commercial pre-mixed solution or
 I will prepare my own sanitizer solution

6. Indicate location for disposal of trash and refuse

Street Name: _____
 City: _____, CA Zip: _____

EXAMPLE PLAN WITH REQUIRED 3 COMPARTMENT SINK

LIST OF MENU/ITEMS BEING SOLD
Espresso, Lattes, Acai Bowl, Fruit Smoothies, Prepackaged Nutrition Bars, and Whole Fruit

FINISH MATERIALS

**Raw wood not permitted to be used as exterior CMFO material*

LOCATION/EQUIPMENT	MATERIAL
Exterior of CMFO	Stainless Steel
Interior of CMFO	Stainless Steel/ Fiberglass Reinforced Panel (FRP)
Food Storage Area	FRP
Food Preparation Compartment	N/A
Other:	Exterior Vinyl Trim

FOOD SERVICE EQUIPMENT LIST

EQUIPMENT	MANUFACTURER	MODEL
Espresso Machine	Nuova Simonelli	Appia Life Compact2
Blender	Vita Mix	36019-ABAB
Undercounter Refrigerator	Bev-Air	UCR27HC
Coffee Brewer	Bunn	Axiom DV APS
Air Pots	Bunn	32130.000
Acrylic Prepackaged Food Display	Custom	Custom
Ice Bin with 2 Piece Lid	Moli International	BIB-1118-D 13"
Soap Dispenser	San Janmar	S30TBK
Paper Towel Dispenser	Bobrick	B-2620

POWER/GAS PLAN

Select all applicable options and fill in the blanks for each one:

- DC Battery* (Quantity 1)
 AC Battery (Quantity)
 Propane Tank (Pounds ; Quantity)
**Requires Inverter*

LEFT SIDE VIEW OF CMFO- Internal View Showing Equipment Placement

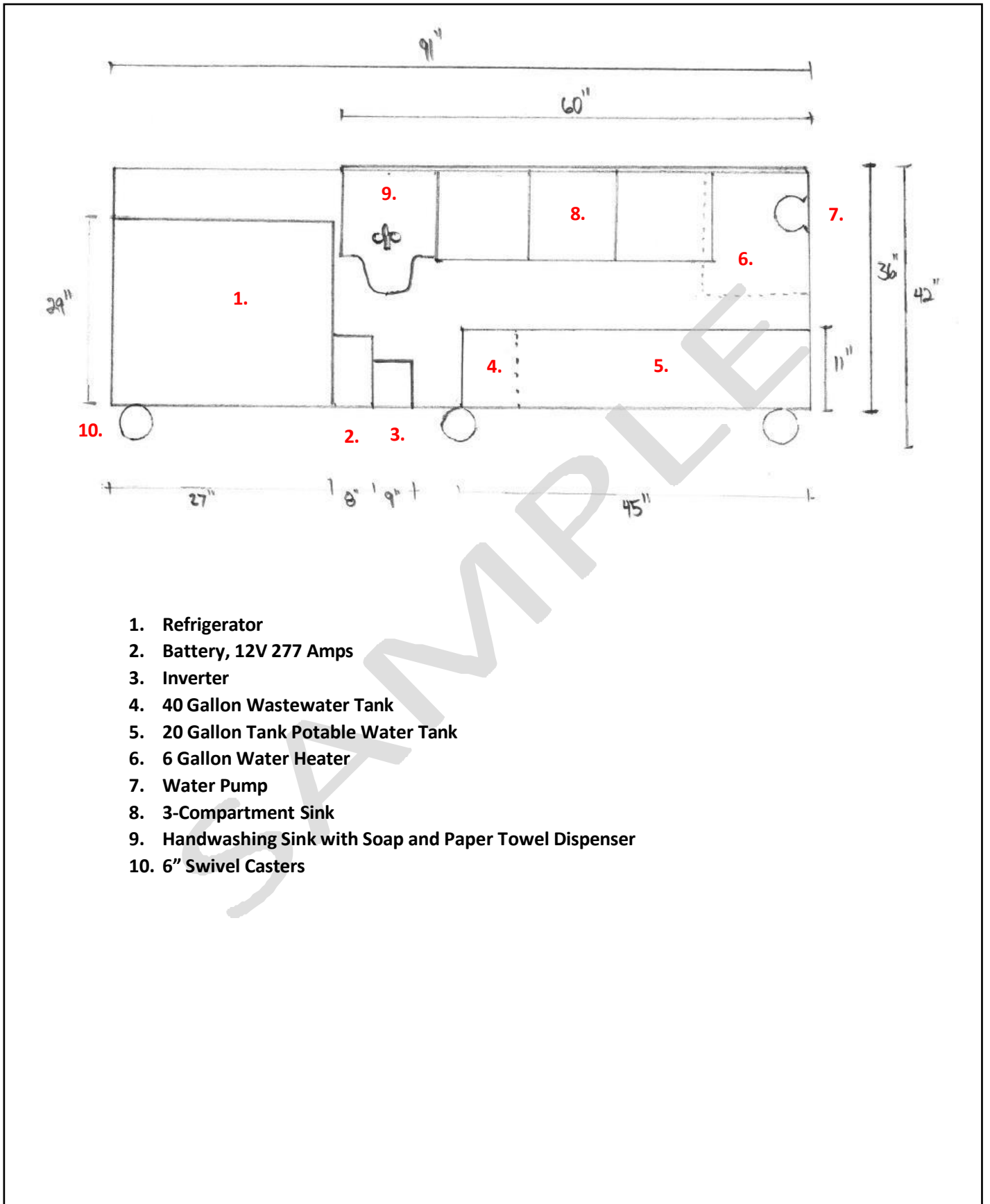

- 1. Refrigerator
- 2. Battery, 12V 277 Amps
- 3. Inverter
- 4. 40 Gallon Wastewater Tank
- 5. 20 Gallon Tank Potable Water Tank
- 6. 6 Gallon Water Heater
- 7. Water Pump
- 8. 3-Compartment Sink
- 9. Handwashing Sink with Soap and Paper Towel Dispenser
- 10. 6" Swivel Casters

RIGHT SIDE VIEW OF CMFO- Showing Customer Side

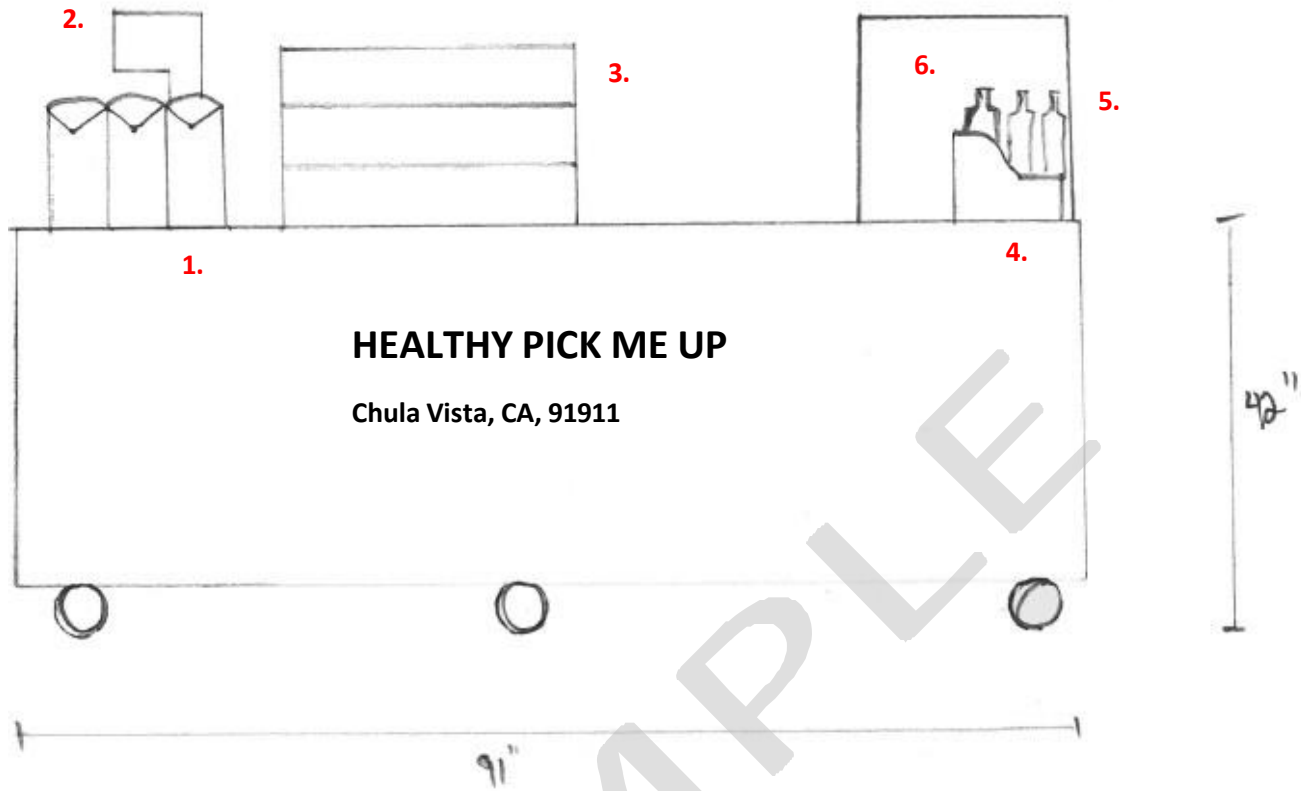

1. Airpot Coffee Dispenser
2. Coffee Brewer
3. Display Shelving
4. Point of Sale- Register
5. Flavored Syrup with Pumps
6. Espresso Machine

***NOTE:** Lettering of the business name: 3" high minimum

City, State, and Zip Code of the permit holder: 1" high minimum

TOP SIDE VIEW OF CMFO

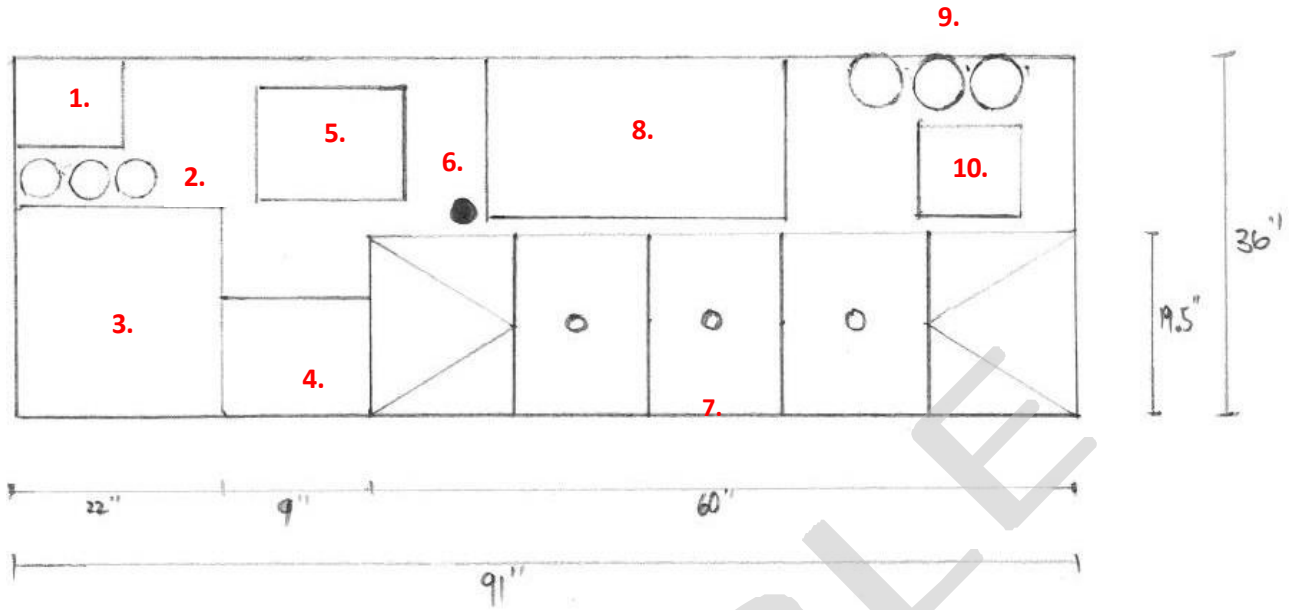

1. Point of Sale - Register
2. Flavored Syrup with Pumps
3. Espresso Machine
4. Blender
5. Ice Bin with 2 Piece Lid
6. Grommet for Umbrella
7. 3-Compartment Sink
8. Display Shelving
9. Airpot Coffee Dispenser
10. Coffee Brewer

LEFT END FROM CUSTOMER SIDE VIEW OF CMFO

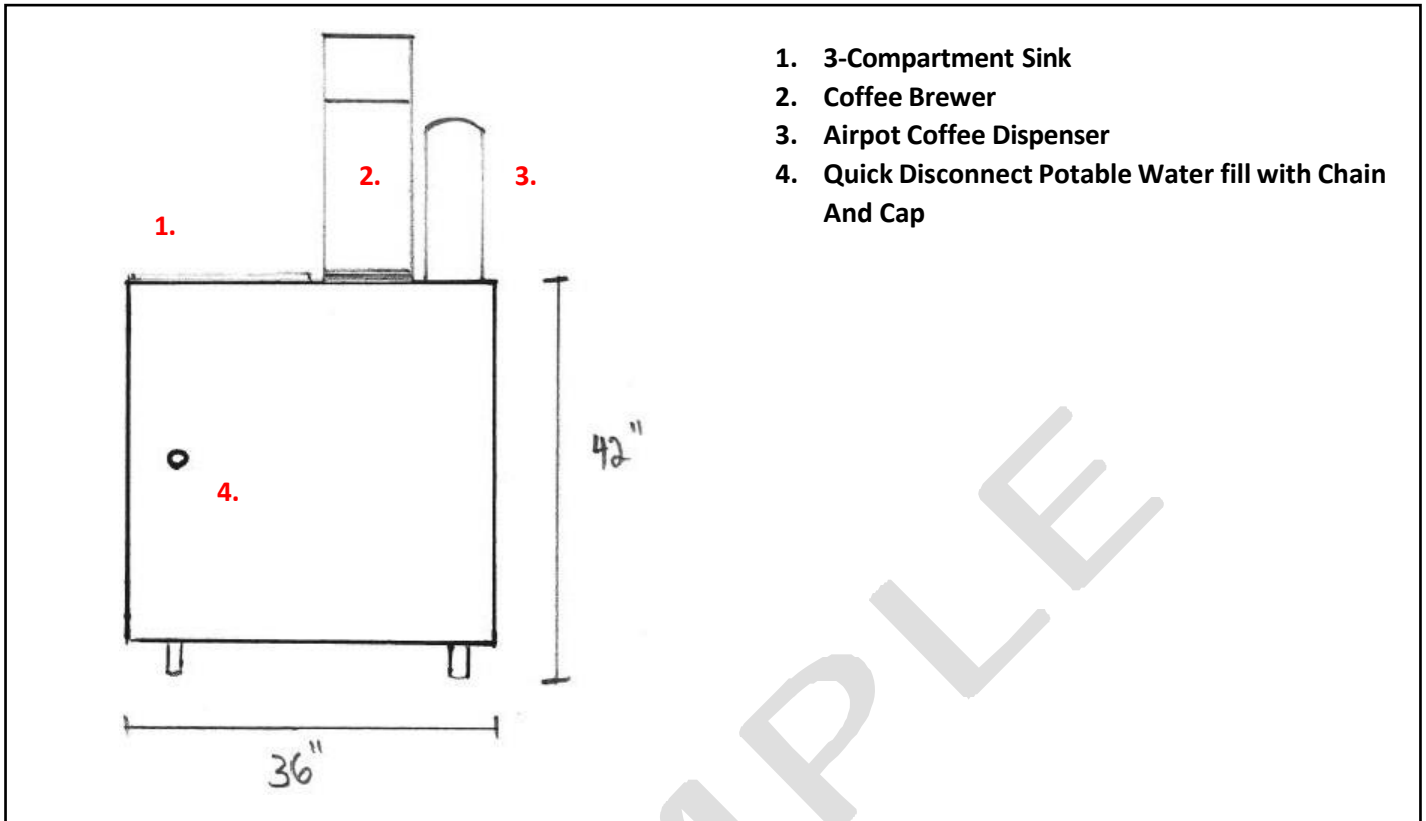

RIGHT END FROM CUSTOMER SIDE VIEW OF CMFO

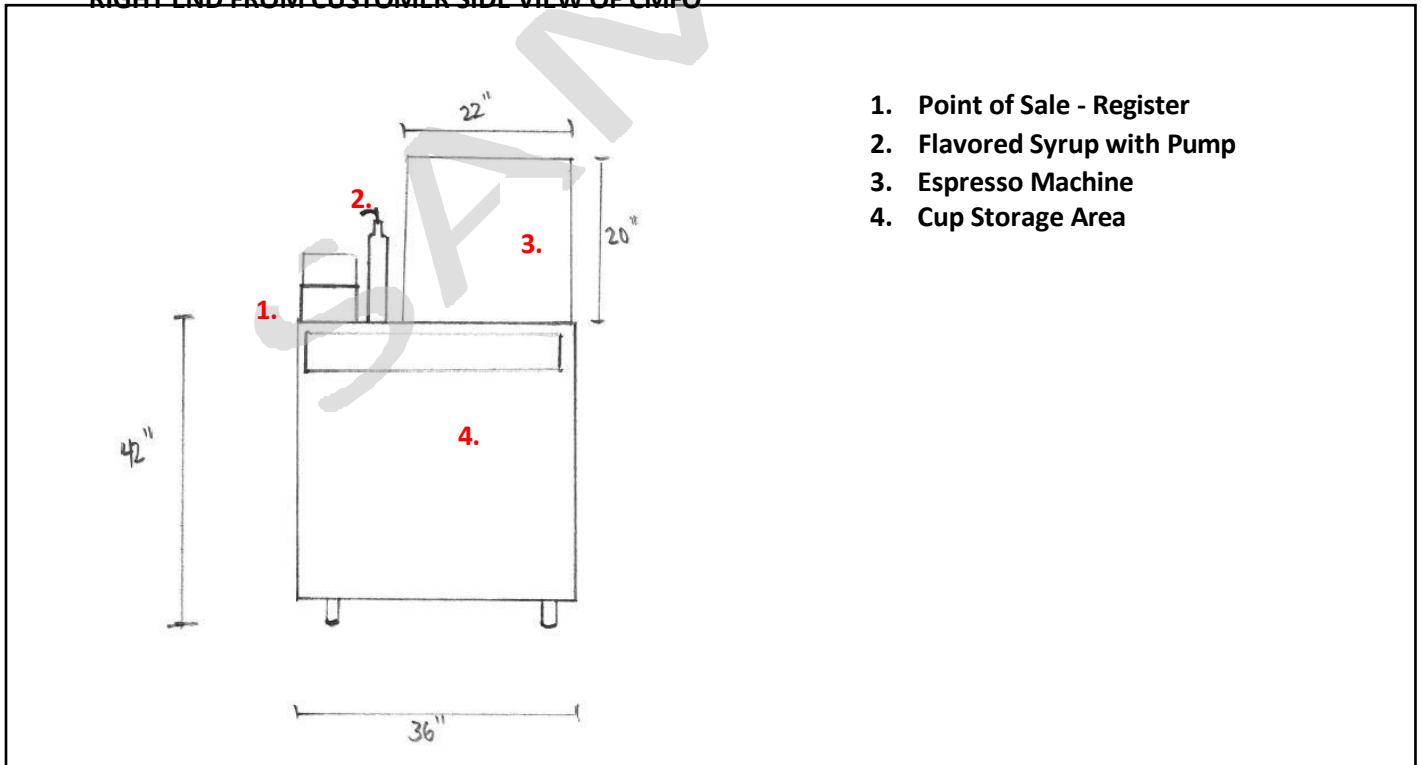

PLUMBING DIAGRAM WITH 3 COMPARTMENT SINK

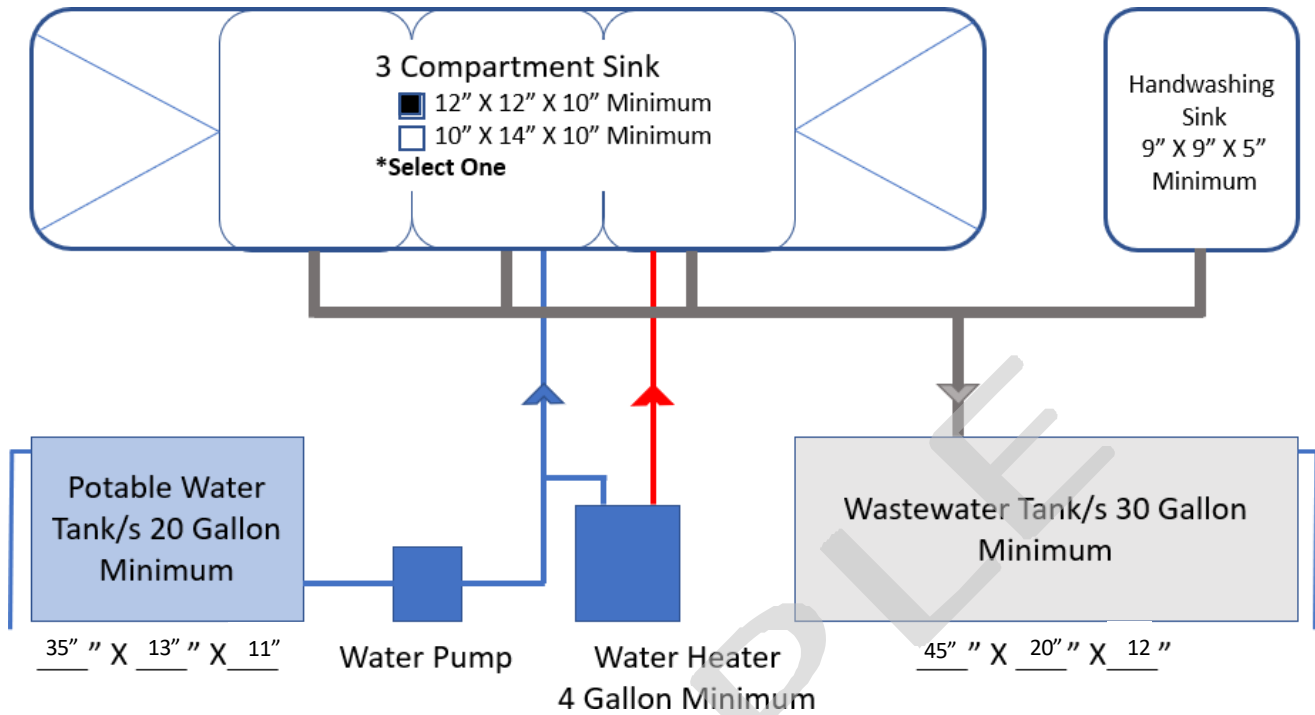

Plumbing Notes:

- All plumbing lines shall be connected to the tanks with watertight seals.
- Potable water lines, couplings, and valves shall be listed to NSF standards for drinking water.
- Potable water tanks and wastewater tanks mounted in the CMFO shall have an air vent overflow installed draining outside of the CMFO in a downward direction covered with 16 mesh per square inch screen.
- Tanks may be removeable. If they are not removeable, they must be equipped with a fill line that has a nonthreaded quick disconnect coupler. They must also be installed sloped towards a drainage outlet equipped with a valve.
- Tanks and hose inlets and outlet fittings shall be protected with a cap and keeper chain, quick disconnect, or closed cabinet when not in use.
- Waste lines must be a different color than the lines for potable water.
- The 3-compartment sink must be stainless steel and equipped with dual integral drainboards that are at least the size of one of the compartments.

WATER PUMP MANUFACTURER AND MODEL: Pentair Shurflo 2088-594-144

WATER HEATER MANUFACTURER AND MODEL: EEMax MiniTank EMT 6

EXAMPLE PLAN WITHOUT 3 COMPARTMENT SINK

LIST OF MENU/ITEMS BEING SOLD
Steamed Hot dogs, Prepackaged- Ketchup, Mustard, Relish, Mayonnaise (shelf stable), Canned Soda, Bottled Water

FINISH MATERIALS

**Raw wood not permitted to be used as exterior CMFO material*

LOCATION/EQUIPMENT	MATERIAL
Exterior of CMFO	Stainless Steel
Interior of CMFO	Stainless Steel/ Fiberglass Reinforced Panel (FRP)
Food Storage Area	FRP
Food Preparation Compartment	N/A
Other:	N/A

FOOD SERVICE EQUIPMENT LIST

EQUIPMENT	MANUFACTURER	MODEL
Undercounter Refrigerator	Bev-Air	UCR27HC
Bun Warmer	APW Wyott	BWD-75N
Electric Steam Table	Wells	5P-SS206-120

POWER/GAS PLAN

Select all applicable options and fill in the blanks for each one:

- DC Battery* (Quantity 1)
 AC Battery (Quantity)
 Propane Tank (Pounds ; Quantity)
- *Requires Inverter*

LEFT SIDE VIEW OF CMFO- Internal View Showing Equipment Placement

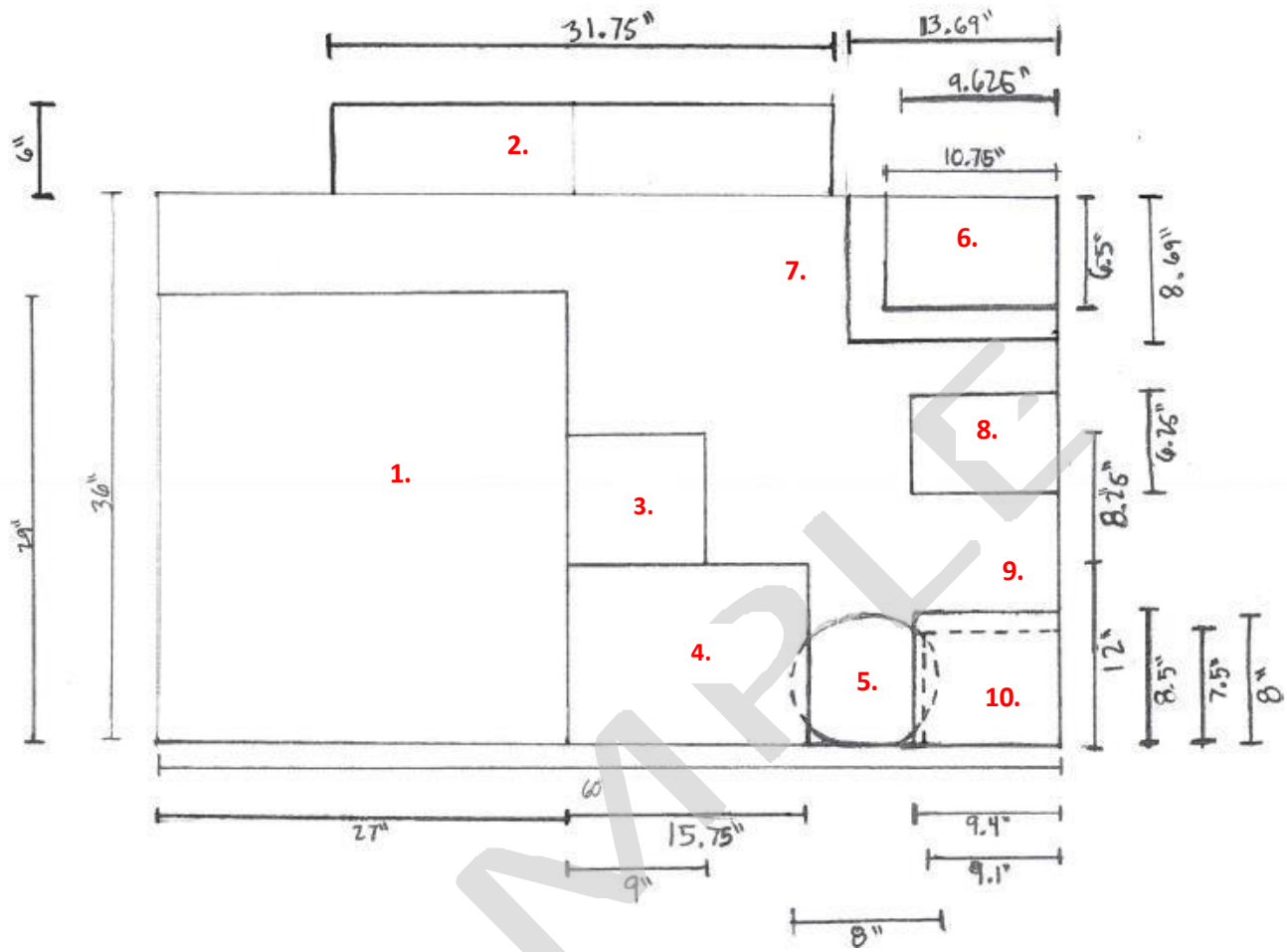

1. Refrigerator
2. Bun Warmer
3. Potable Water Tank
4. Wastewater Tank
5. Water Pump
6. Handwashing Sink with Soap and Paper Towel Dispenser
7. Drop-in Steamer
8. Water Heater
9. Battery 12V, 277Amp
10. Inverter

RIGHT SIDE VIEW OF CMFO- Showing Customer Side

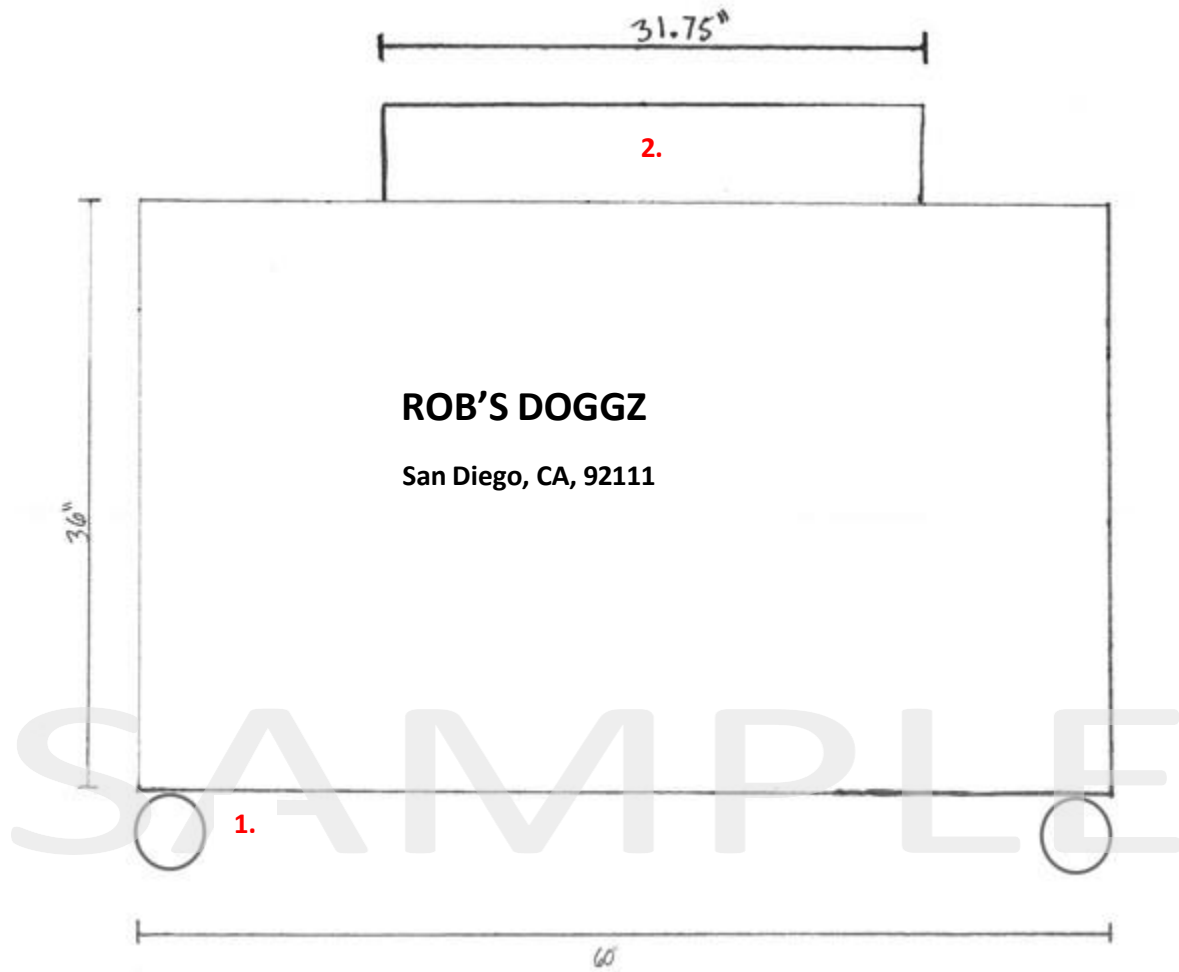

- 1. 6" Swivel Casters
- 2. Bun Warmer

***NOTE:** Lettering of the business name: 3" high minimum
City, State, and Zip Code of the permit holder: 1" high minimum

TOP SIDE VIEW OF CMFO

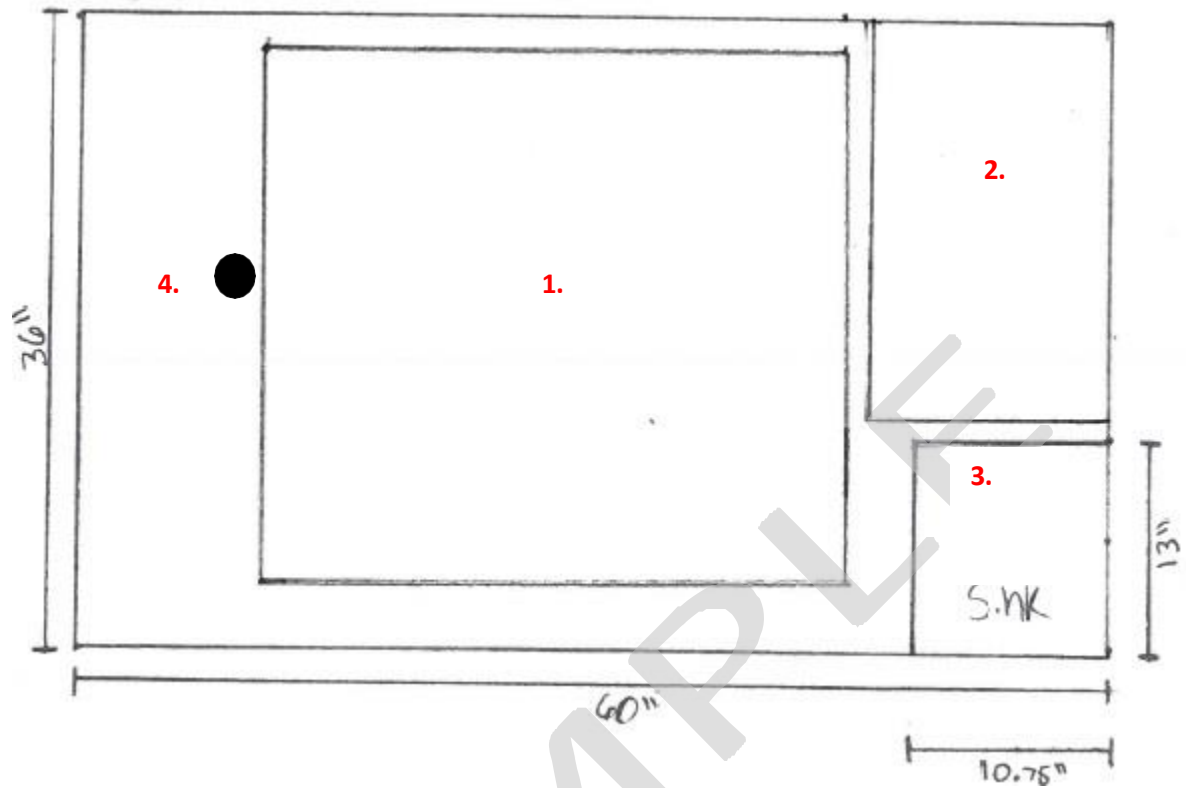

1. Bun Warmer
2. Drop-in Steam Table
3. Handwashing Sink with Soap and Paper Towel Dispenser
4. Grommet for Umbrella

LEFT END FROM CUSTOMER SIDE VIEW OF CMFO

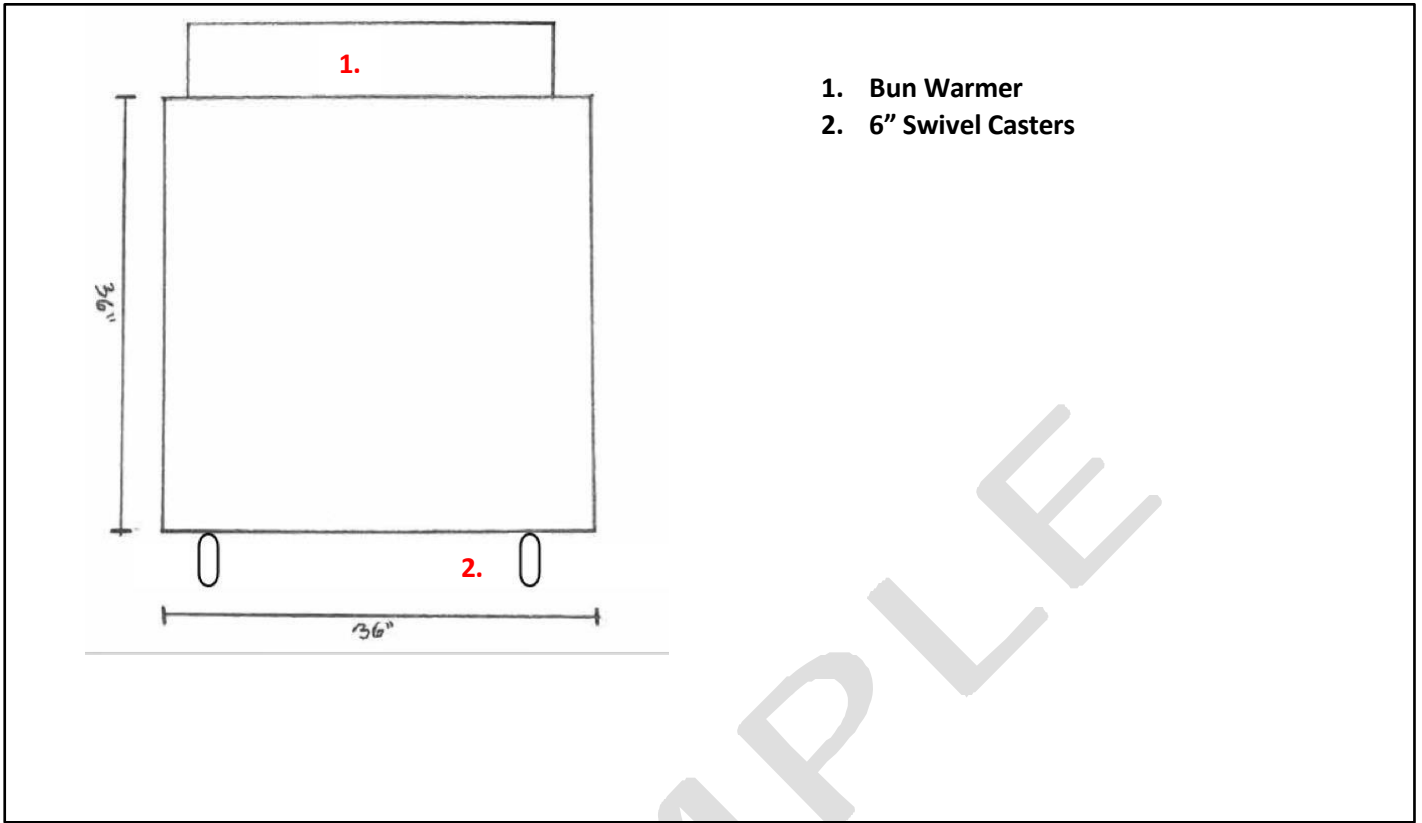

RIGHT END FROM CUSTOMER SIDE VIEW OF CMFO

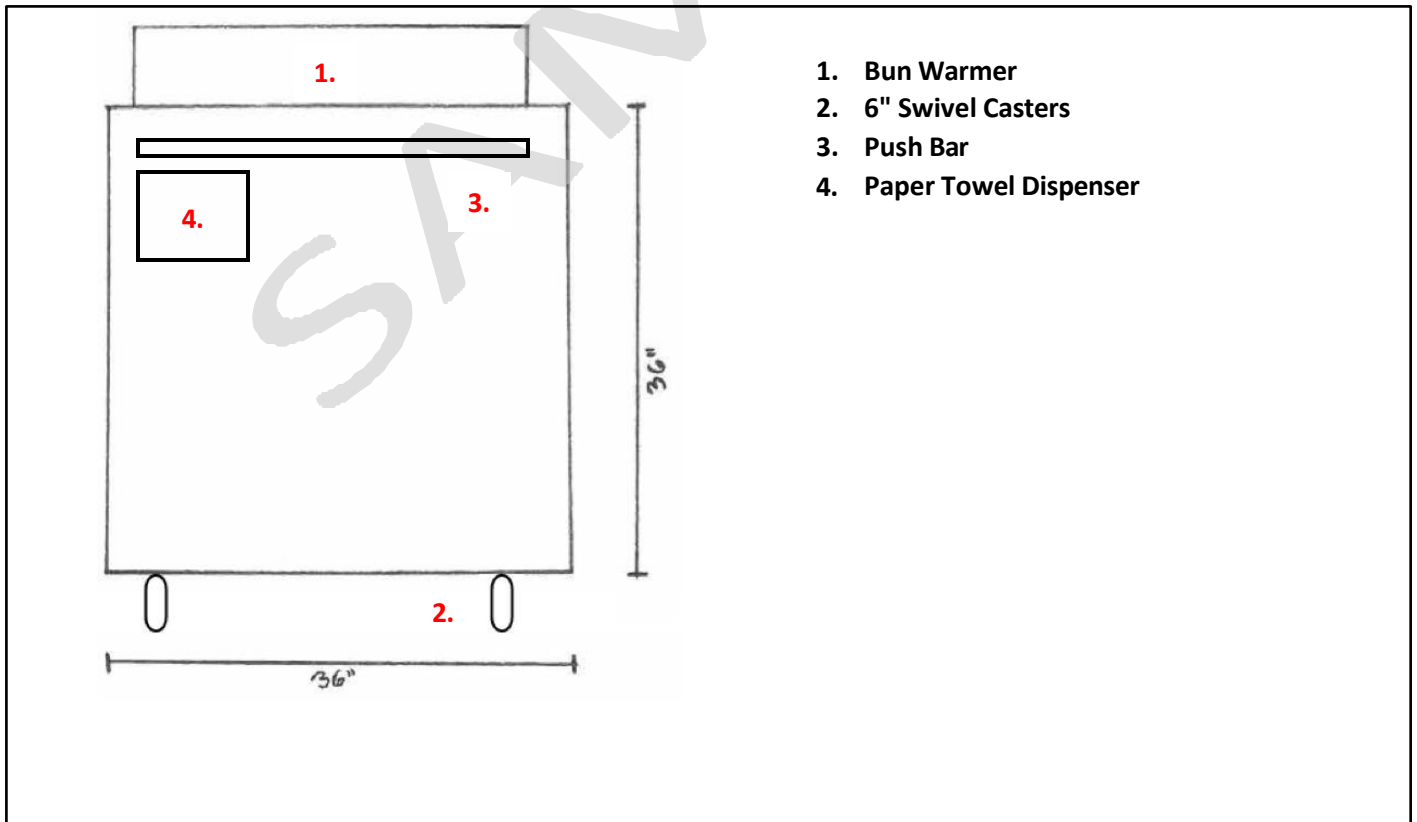

PLUMBING DIAGRAM WITHOUT 3 COMPARTMENT SINK

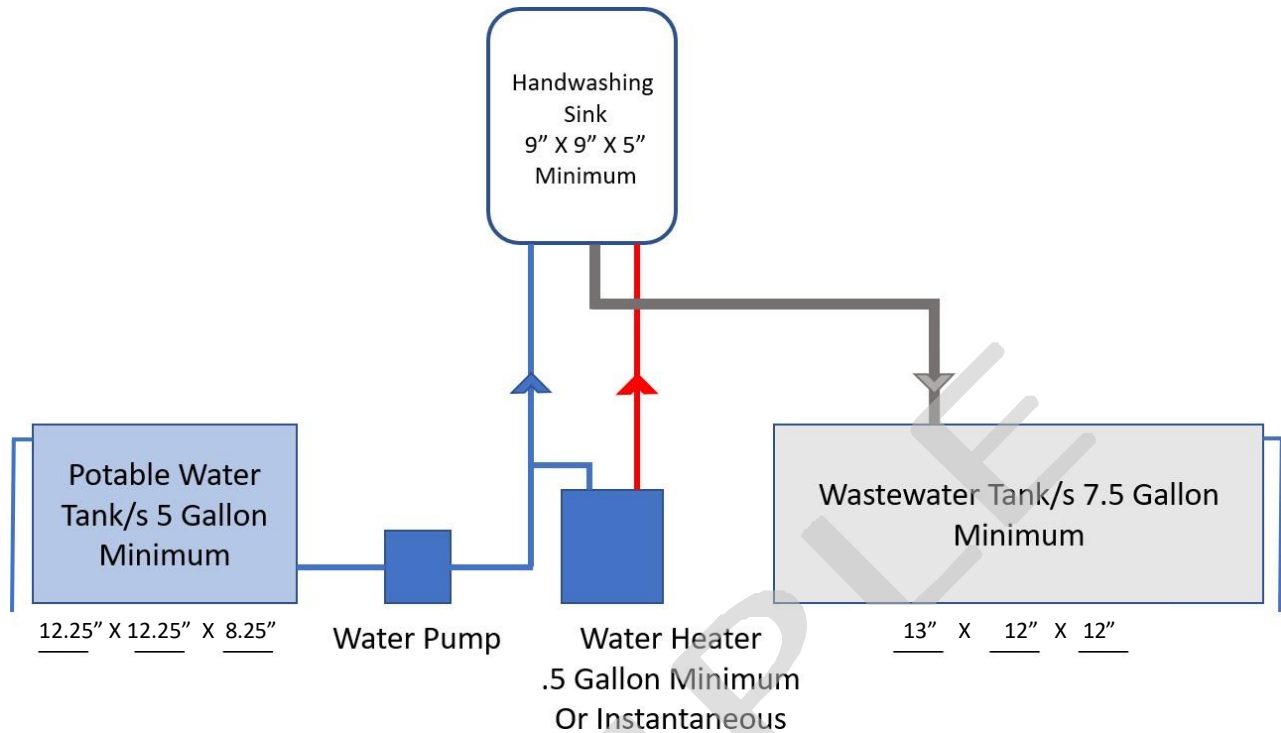

Plumbing Notes:

- Water heater is optional.
- All plumbing lines shall be connected to the tanks with watertight seals.
- Potable water lines, couplings, and valves shall be listed to NSF standards for drinking water.
- Potable water tanks and wastewater tanks mounted in the CMFO shall have an air vent overflow installed draining outside of the CMFO in a downward direction covered with 16 mesh per square inch screen.
- Tanks may be removeable. If they are not removeable, they must be equipped with a fill line that has a nonthreaded quick disconnect coupler. They must also be installed sloped towards a drainage outlet equipped with a valve.
- Tanks and hose inlets and outlet fittings shall be protected with a cap and keeper chain, quick disconnect, or closed cabinet when not in use.
- Waste lines must be a different color than the lines for potable water.

WATER PUMP MANUFACTURER AND MODEL: Pentair Shurflo 2088-594-144

WATER HEATER MANUFACTURER AND MODEL: Chronomite Labs SR-20L/120 HTR-I

PLUMBING NOTE EXAMPLES

The following are some examples of the types of equipment that can be used to accomplish the code requirements.

1. All plumbing lines shall be connected to the tanks with watertight seals.



Watertight seal with attached ball valve on the side wall of a tank



Inside tank view of watertight seal

2. Potable water lines, couplings, and valves shall be listed to NSF standards for drinking water.



PEX Piping Ball Valve



ANSI/NSF 61 Label on handle



Straight Coupler with ANSI/NSF Label on bag

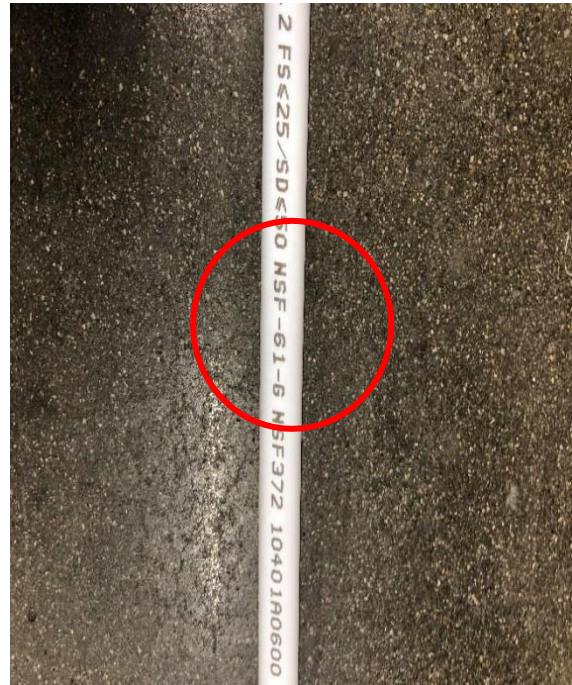

PEX Potable Water line with NSF- 61 label

3. Potable water tanks and wastewater tanks mounted in the CMFO shall have an air vent overflow installed draining outside of the CMFO in a downward direction covered with 16 mesh per square inch screen.



Pipe with mesh



Typical mesh screens

4. Tanks may be removable. If they are not removable, they must be equipped with a fill line that has a nonthreaded quick disconnect coupler. They must also be installed sloped towards a drainage outlet equipped with a valve.



Fill line to non-portable tank with a quick disconnect coupler



Removable portable tanks



Non-portable tank with connections to vent, fill, drain, and for the water pump



Removable portable tank with quick disconnect for supply or waste water (black lines typically denote waste)

5. Tanks and hose inlets and outlet fittings shall be protected with a quick disconnect



Quick disconnect coupler

6. Waste lines shall not be the same color as the lines for potable water.



Potable white PVC line with NSF label



Non-potable/wastewater black PVC pipe



Blue potable PEX line with NSF label



Clear potable vinyl line with NSF